

FAA FORM 8130-6, APPLICATION FOR U.S. AIRWORTHINESS CERTIFICATE

Form Approved O.M.B. No. 2120-0018  
Expiration Date 02/28/2013

Accepted RJ Jan/24/2012

		<b>APPLICATION FOR U.S. AIRWORTHINESS CERTIFICATE</b>		INSTRUCTIONS - Print or type. Do not write in shaded areas; these are for FAA use only. Submit original only to an authorized FAA Representative. If additional space is required, use attachment. For special flight permits complete Sections II, VI, and VII as applicable.																																						
I. AIRCRAFT DESCRIPTION	1. REGISTRATION MARK N606RN	2. AIRCRAFT BUILDER'S NAME (Make) RAYTHEON	3. AIRCRAFT MODEL DESIGNATION COBAR COBR A	4. YR. MFR. 2006	FAA CODING.																																					
	5. AIRCRAFT SERIAL NO. 006	6. ENGINE BUILDER'S NAME (Make) DESERT AIRCRAFT	7. ENGINE MODEL DESIGNATION DA-150																																							
	8. NUMBER OF ENGINES ONE	9. PROPELLER BUILDER'S NAME (Make) MEJZLICK	10. PROPELLER MODEL DESIGNATION 28 X 12-3B	11. AIRCRAFT IS (Check if applicable) <input type="checkbox"/> EXPORT <input checked="" type="checkbox"/> IMPORT																																						
	APPLICATION IS HEREBY MADE FOR: (Check applicable items)																																									
II. CERTIFICATION REQUESTED	A <input type="checkbox"/> STANDARD AIRWORTHINESS CERTIFICATE (Indicate category) <input type="checkbox"/> NORMAL <input type="checkbox"/> UTILITY <input type="checkbox"/> ACROBATIC <input type="checkbox"/> TRANSPORT <input type="checkbox"/> COMMUTER <input type="checkbox"/> BALLOON <input type="checkbox"/> OTHER																																									
	B <input checked="" type="checkbox"/> SPECIAL AIRWORTHINESS CERTIFICATE (Check appropriate items)																																									
	7	PRIMARY																																								
	9	LIGHT-SPORT (Indicate Class) <input type="checkbox"/> Airplane <input type="checkbox"/> Power-Parachute <input type="checkbox"/> Weight-Shift-Control <input type="checkbox"/> Glider <input type="checkbox"/> Lighter than Air																																								
	2	LIMITED																																								
	5	PROVISIONAL (Indicate class) <input type="checkbox"/> CLASS I <input type="checkbox"/> CLASS II																																								
	3	RESTRICTED (Indicate operation(s) to be conducted) <table border="0" style="width: 100%;"> <tr> <td>1</td><td>AGRICULTURE AND PEST CONTROL</td> <td>2</td><td>AERIAL SURVEY</td> <td>3</td><td>AERIAL ADVERTISING</td> </tr> <tr> <td>4</td><td>FOREST (Wildlife conservation)</td> <td>5</td><td>PATROLLING</td> <td>6</td><td>WEATHER CONTROL</td> </tr> <tr> <td>0</td><td colspan="5">OTHER (Specify)</td> </tr> </table>					1	AGRICULTURE AND PEST CONTROL	2	AERIAL SURVEY	3	AERIAL ADVERTISING	4	FOREST (Wildlife conservation)	5	PATROLLING	6	WEATHER CONTROL	0	OTHER (Specify)																						
	1	AGRICULTURE AND PEST CONTROL	2	AERIAL SURVEY	3	AERIAL ADVERTISING																																				
	4	FOREST (Wildlife conservation)	5	PATROLLING	6	WEATHER CONTROL																																				
	0	OTHER (Specify)																																								
	4	EXPERIMENTAL (Indicate operation(s) to be conducted) <table border="0" style="width: 100%;"> <tr> <td>1</td><td>RESEARCH AND DEVELOPMENT</td> <td>2</td><td>AMATEUR BUILT</td> <td>3</td><td>EXHIBITION</td> </tr> <tr> <td>4</td><td>AIR RACING</td> <td>5</td><td>CREW TRAINING</td> <td>6</td><td>MARKET SURVEY</td> </tr> <tr> <td>0</td><td colspan="5">TO SHOW COMPLIANCE WITH THE CFR</td> </tr> <tr> <td>8</td><td>OPERATING LIGHT-SPORT</td> <td colspan="4">                             8A <input type="checkbox"/> Existing aircraft without an airworthiness certificate &amp; do not meet § 103.1                              8B <input type="checkbox"/> Operating Light-Sport Kit-built                              8C <input type="checkbox"/> Operating light-sport previously issued special light-sport category airworthiness certificate under § 21.190                         </td> </tr> <tr> <td>9</td><td>UNMANNED AIRCRAFT</td> <td>9A <input checked="" type="checkbox"/></td><td>RESEARCH AND DEVELOPMENT</td> <td>9C <input checked="" type="checkbox"/></td><td>CREW TRAINING</td> </tr> <tr> <td></td><td></td> <td>9B <input checked="" type="checkbox"/></td><td colspan="3">MARKET SURVEY</td> </tr> </table>					1	RESEARCH AND DEVELOPMENT	2	AMATEUR BUILT	3	EXHIBITION	4	AIR RACING	5	CREW TRAINING	6	MARKET SURVEY	0	TO SHOW COMPLIANCE WITH THE CFR					8	OPERATING LIGHT-SPORT	8A <input type="checkbox"/> Existing aircraft without an airworthiness certificate & do not meet § 103.1 8B <input type="checkbox"/> Operating Light-Sport Kit-built 8C <input type="checkbox"/> Operating light-sport previously issued special light-sport category airworthiness certificate under § 21.190				9	UNMANNED AIRCRAFT	9A <input checked="" type="checkbox"/>	RESEARCH AND DEVELOPMENT	9C <input checked="" type="checkbox"/>	CREW TRAINING			9B <input checked="" type="checkbox"/>	MARKET SURVEY		
	1	RESEARCH AND DEVELOPMENT	2	AMATEUR BUILT	3	EXHIBITION																																				
4	AIR RACING	5	CREW TRAINING	6	MARKET SURVEY																																					
0	TO SHOW COMPLIANCE WITH THE CFR																																									
8	OPERATING LIGHT-SPORT	8A <input type="checkbox"/> Existing aircraft without an airworthiness certificate & do not meet § 103.1 8B <input type="checkbox"/> Operating Light-Sport Kit-built 8C <input type="checkbox"/> Operating light-sport previously issued special light-sport category airworthiness certificate under § 21.190																																								
9	UNMANNED AIRCRAFT	9A <input checked="" type="checkbox"/>	RESEARCH AND DEVELOPMENT	9C <input checked="" type="checkbox"/>	CREW TRAINING																																					
		9B <input checked="" type="checkbox"/>	MARKET SURVEY																																							
8	SPECIAL FLIGHT PERMIT (Indicate operation to be conducted, then complete Section VI or VII as applicable on reverse side) <table border="0" style="width: 100%;"> <tr> <td>1</td><td colspan="5">FERRY FLIGHT FOR REPAIRS, ALTERATIONS, MAINTENANCE, OR STORAGE</td> </tr> <tr> <td>2</td><td colspan="5">EVACUATE FROM AREA OF IMPENDING DANGER</td> </tr> <tr> <td>3</td><td colspan="5">OPERATION IN EXCESS OF MAXIMUM CERTIFICATED TAKE-OFF WEIGHT</td> </tr> <tr> <td>4</td><td>DELIVERING OR EXPORTING</td> <td>5</td><td colspan="3">PRODUCTION FLIGHT TESTING</td> </tr> <tr> <td>6</td><td colspan="5">CUSTOMER DEMONSTRATION FLIGHTS</td> </tr> </table>					1	FERRY FLIGHT FOR REPAIRS, ALTERATIONS, MAINTENANCE, OR STORAGE					2	EVACUATE FROM AREA OF IMPENDING DANGER					3	OPERATION IN EXCESS OF MAXIMUM CERTIFICATED TAKE-OFF WEIGHT					4	DELIVERING OR EXPORTING	5	PRODUCTION FLIGHT TESTING			6	CUSTOMER DEMONSTRATION FLIGHTS											
1	FERRY FLIGHT FOR REPAIRS, ALTERATIONS, MAINTENANCE, OR STORAGE																																									
2	EVACUATE FROM AREA OF IMPENDING DANGER																																									
3	OPERATION IN EXCESS OF MAXIMUM CERTIFICATED TAKE-OFF WEIGHT																																									
4	DELIVERING OR EXPORTING	5	PRODUCTION FLIGHT TESTING																																							
6	CUSTOMER DEMONSTRATION FLIGHTS																																									
C	6 MULTIPLE AIRWORTHINESS CERTIFICATE (Check ABOVE "Restricted Operation" and "Standard" or "Limited" as applicable)																																									
III. OWNER'S CERTIFICATION	A. REGISTERED OWNER (As shown on certificate of aircraft registration)		IF DEALER, CHECK HERE																																							
	NAME RAYTHEON COMPANY		ADDRESS P.O. BOX 11337, TUCSON, AZ 85734-1337																																							
	B. AIRCRAFT CERTIFICATION BASIS (Check applicable blocks and complete items as indicated)																																									
	AIRCRAFT SPECIFICATION OR TYPE CERTIFICATE DATA SHEET (Give No. and Revision No.) N/A		<input checked="" type="checkbox"/> AIRWORTHINESS DIRECTIVES (Check if all applicable ADs are complied with and give the number of the last AD SUPPLEMENT available in the biweekly series as of the date of application) SMALL AIRCRAFT BI-WEEKLY, 2011-25																																							
	AIRCRAFT LISTING (Give page number(s)) N/A		<input type="checkbox"/> SUPPLEMENTAL TYPE CERTIFICATE (List number of each STC incorporated) N/A																																							
	C. AIRCRAFT OPERATION AND MAINTENANCE RECORDS																																									
<input checked="" type="checkbox"/>	CHECK IF RECORDS IN COMPLIANCE WITH 14 CFR section 91.417	TOTAL AIRFRAME HOURS 7.0	3	EXPERIMENTAL ONLY (Enter hours flown since last certificate issued or renewed) 6.6																																						
D. CERTIFICATION - I hereby certify that I am the registered owner (or his agent) of the aircraft described above, that the aircraft is registered with the Federal Aviation Administration in accordance with Title 49 of the United States Code 44101 et seq. and applicable Federal Aviation Regulations, and that the aircraft has been inspected and is airworthy and eligible for the airworthiness certificate requested.																																										
DATE OF APPLICATION DECEMBER 20, 2011		NAME AND TITLE (Print or type) JOHN E. CALLOWAY, FLIGHT TEST OPS MANAGER		SIGNATURE 																																						
IV. INSPECTION AGENCY VERIFICATION	A. THE AIRCRAFT DESCRIBED ABOVE HAS BEEN INSPECTED AND FOUND AIRWORTHY BY: (Complete the section only if 14 CFR part 21.183(a) applies)																																									
	2	14 CFR part 121 CERTIFICATE HOLDER (Give Certificate No.)	CERTIFICATED MECHANIC (Give Certificate No.)	6	CERTIFICATED REPAIR STATION (Give Certificate No.)																																					
	5	AIRCRAFT MANUFACTURER (Give name or firm)																																								
DATE		TITLE		SIGNATURE																																						
V. FAA REPRESENTATIVE CERTIFICATION	(Check ALL applicable block items A and B)																																									
	A. I find that the aircraft described in Section I or VII meets requirements for <input type="checkbox"/> THE CERTIFICATE REQUESTED <input type="checkbox"/> AMENDMENT OR MODIFICATION OF CURRENT AIRWORTHINESS CERTIFICATE																																									
	B. Inspection for a special flight permit under Section VII was conducted by:																																									
	<input type="checkbox"/> FAA INSPECTOR		<input type="checkbox"/> FAA DESIGNEE																																							
<input type="checkbox"/> CERTIFICATE HOLDER UNDER		<input type="checkbox"/> 14 CFR part 65 <input type="checkbox"/> 14 CFR part 121 OR 135 <input type="checkbox"/> 14 CFR part 145																																								
DATE 12/20/11	MIDO/FSDO OFFICE PHX MIDO	FAA INSPECTOR'S SIGNATURE AND NO.  George Bullis ASF		FAA INSPECTOR'S CERTIFICATION FILE REVIEW SIGNATURE																																						

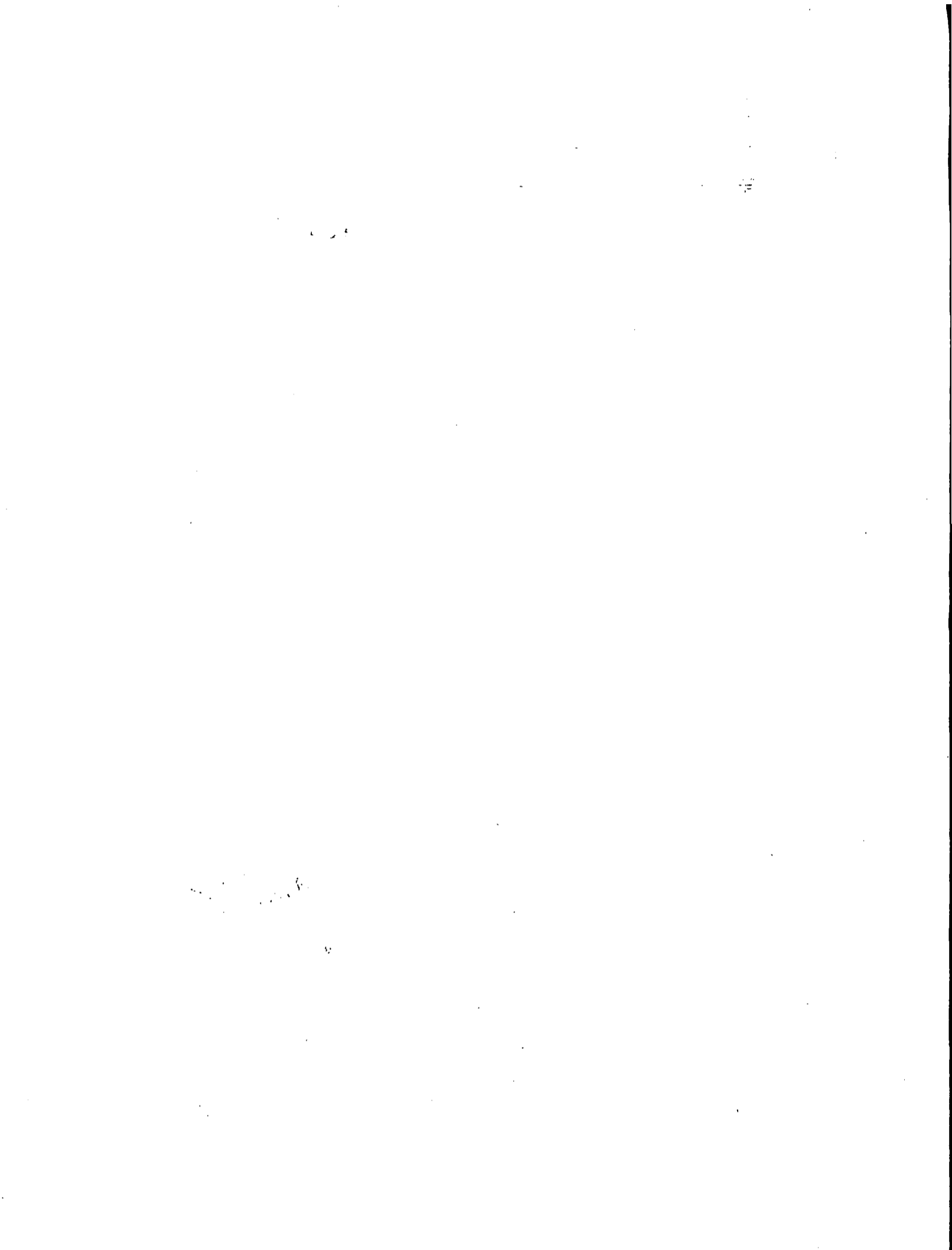

<b>VI. PRODUCTION FLIGHT TESTING</b>	A. MANUFACTURER			
	NAME		ADDRESS	
	B. PRODUCTION BASIS <i>(Check applicable item)</i>			
	<input type="checkbox"/> PRODUCTION CERTIFICATE <i>(Give production certificate number)</i>			
	<input type="checkbox"/> TYPE CERTIFICATE			
	<input type="checkbox"/> OTHER:			
C. GIVE QUANTITY OF CERTIFICATES REQUIRED FOR OPERATING NEEDS				
DATE OF APPLICATION	NAME AND TITLE <i>(Print or type)</i>	SIGNATURE		
<b>VII. SPECIAL FLIGHT PERMIT PURPOSES OTHER THAN PRODUCTION FLIGHT TEST</b>	A. DESCRIPTION OF AIRCRAFT			
	REGISTERED OWNER		ADDRESS	
	BUILDER <i>(Make)</i>		MODEL	
	SERIAL NUMBER		REGISTRATION MARK	
	B. DESCRIPTION OF FLIGHT			
	FROM		CUSTOMER DEMONSTRATION FLIGHTS <input type="checkbox"/> <i>(Check if applicable)</i>	
	TO			
	VIA	DEPARTURE DATE	DURATION	
	C. CREW REQUIRED TO OPERATE THE AIRCRAFT AND ITS EQUIPMENT			
	<input type="checkbox"/> PILOT	<input type="checkbox"/> CO-PILOT	<input type="checkbox"/> FLIGHT ENGINEER	<input type="checkbox"/> OTHER <i>(Specify)</i>
	D. THE AIRCRAFT DOES NOT MEET THE APPLICABLE AIRWORTHINESS REQUIREMENTS AS FOLLOWS:			
	E. THE FOLLOWING RESTRICTIONS ARE CONSIDERED NECESSARY FOR SAFE OPERATION: <i>(Use attachment if necessary)</i>			
F. CERTIFICATION - I hereby certify that I am the registered owner (or his agent) of the aircraft described above; that the aircraft is registered with the Federal Aviation Administration in accordance with Title 49 of the United States Code 44101 <u>et seq.</u> and applicable Federal Aviation Regulations; and that the aircraft has been inspected and is safe for the flight described.				
DATE	NAME AND TITLE <i>(Print or type)</i>	SIGNATURE		
<b>VIII. AIRWORTHINESS DOCUMENTATION (FAA/DESIGNEE use only)</b>	<input checked="" type="checkbox"/>	A. Operating Limitations and Markings in Compliance With 14 CFR Section 91.9, As Applicable	<input type="checkbox"/>	G. Statement of Conformity, FAA Form 8130-9 <i>(Attach when required)</i>
	<input checked="" type="checkbox"/>	B. Current Operating Limitations Attached	<input type="checkbox"/>	H. Foreign Airworthiness Certification for Import Aircraft <i>(Attach when required)</i>
	<input checked="" type="checkbox"/>	C. Data, Drawings, Photographs, etc. <i>(Attach when required)</i>	<input checked="" type="checkbox"/>	I. Previous Airworthiness Certificate Issued in Accordance With 14 CFR Section 21.191(a)(c)(f) CAR _____ <i>(Original attached)</i>
	<input checked="" type="checkbox"/>	D. Current Weight and Balance Information Available in Aircraft	<input checked="" type="checkbox"/>	J. Current Airworthiness Certificate Issued in Accordance With 14 CFR Section 21.191(a)(c)(f) <i>(Copy attached)</i>
	<input type="checkbox"/>	E. Major Repair and Alteration, FAA Form 337 <i>(Attach when required)</i>	<input checked="" type="checkbox"/>	K. Light-Sport Aircraft Statement of Compliance, FAA Form 8130-15 <i>(Attach when required)</i>
	<input checked="" type="checkbox"/>	F. This Inspection Recorded in Aircraft Records		

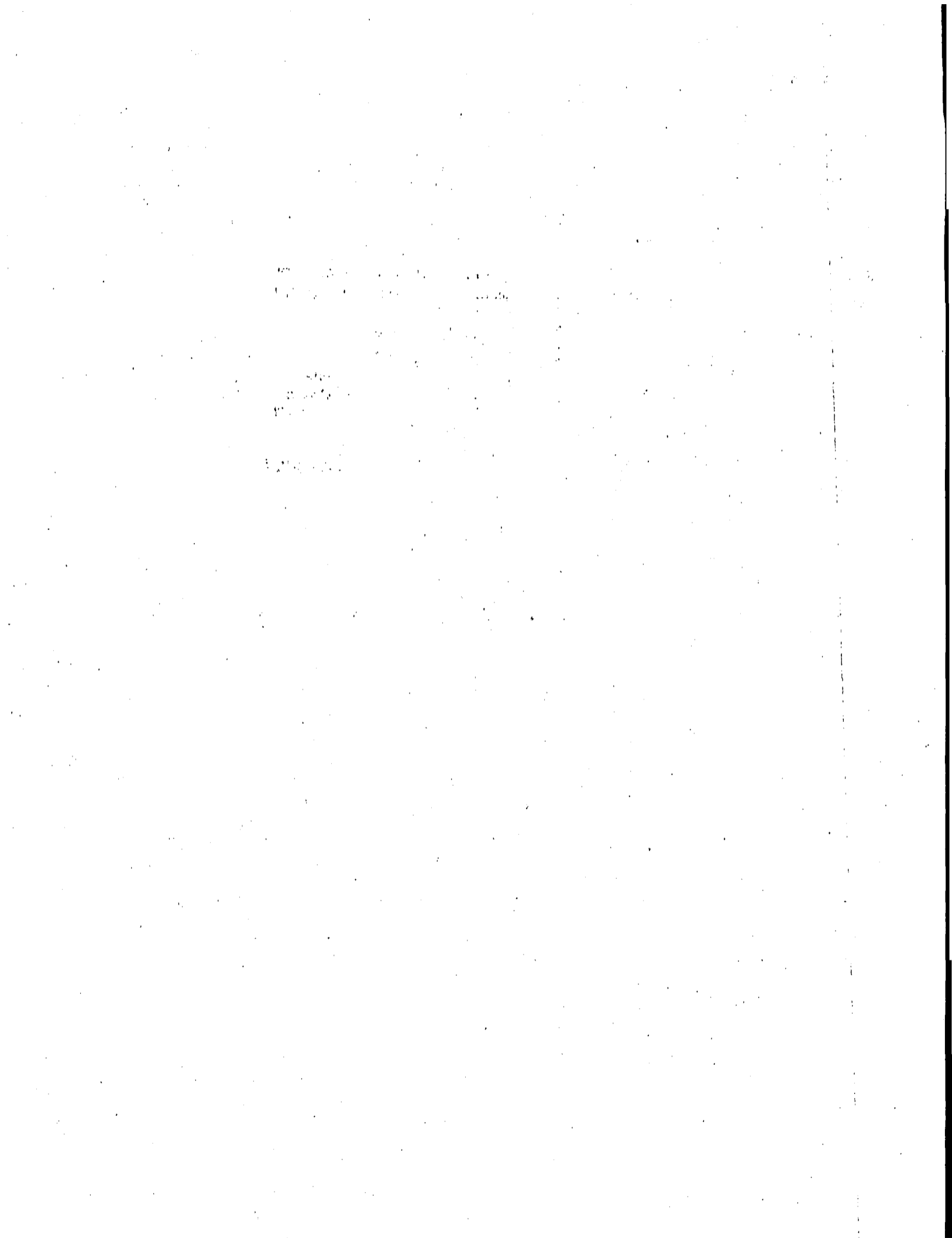

UNITED STATES OF AMERICA  
 DEPARTMENT OF TRANSPORTATION - FEDERAL AVIATION ADMINISTRATION  
**SPECIAL AIRWORTHINESS CERTIFICATE**

<b>A</b>	CATEGORY/DESIGNATION	Experimental (Unmanned Aircraft)		
	PURPOSE	Research and Development, Crew Training, and/or Market Survey		
<b>B</b>	MANUFACTURER	NAME	N/A	
		ADDRESS	N/A	
<b>C</b>	FLIGHT	FROM	N/A	
		TO	N/A	
<b>D</b>	N- 606RN	SERIAL NO.	006	
	BUILDER	Raytheon Company	MODEL	Cobra
<b>E</b>	DATE OF ISSUANCE	December 20, 2011	EXPIRY	December 19, 2012
	OPERATING LIMITATIONS DATED	12/20/11	(ARE PART OF THIS CERTIFICATE)	
<b>E</b>	SIGNATURE OF FAA REPRESENTATIVE	DESIGNATION OR OFFICE NO.		
	<i>George Bullis</i> George Bullis	Phoenix MIDO NM-50		

Any alteration, reproduction or misuse of this certificate may be punishable by a fine not exceeding \$1,000 or imprisonment not exceeding 3 years, or both. THIS CERTIFICATE MUST BE DISPLAYED IN THE AIRCRAFT IN ACCORDANCE WITH APPLICABLE TITLE 14, CODE OF FEDERAL REGULATIONS (CFR).

<b>A</b>	This airworthiness certificate is issued under the authority of Public Law 104-6, 49 United States Code (USC) 44704 and Title 14 Code of Federal Regulations (CFR).
<b>B</b>	The airworthiness certificate authorizes the manufacturer named on the reverse side to conduct production flight tests, and only production flight tests, of aircraft registered in his name. No person may conduct production flight tests under this certificate: (1) Carrying persons or property for compensation or hire; and/or (2) Carrying persons not essential to the purpose of the flight.
<b>C</b>	This airworthiness certificate authorizes the flight specified on the reverse side for the purpose shown in Block A.
<b>D</b>	This airworthiness certificate certifies that as of the date of issuance, the aircraft to which issued has been inspected and found to meet the requirements of the applicable CFR. The aircraft does not meet the requirements of the applicable comprehensive and detailed airworthiness code as provided by Annex 8 to the Convention On International Civil Aviation. No person may operate the aircraft described on the reverse side: (1) except in accordance with the applicable CFR and in accordance with conditions and limitations which may be prescribed by the Administrator as part of this certificate; (2) over any foreign country without the special permission of that country.
<b>E</b>	Unless sooner surrendered, suspended, or revoked, this airworthiness certificate is effective for the duration and under the conditions prescribed in 14 CFR, Part 21, Section 21.181 or 21.217.

UNITED STATES OF AMERICA  
 DEPARTMENT OF TRANSPORTATION - FEDERAL AVIATION ADMINISTRATION  
**SPECIAL AIRWORTHINESS CERTIFICATE**

<b>A</b>	CATEGORY/DESIGNATION <u>Experimental (Unmanned Aircraft)</u>	
	PURPOSE <u>Research and Development, Crew Training, and/or Market Survey</u>	
<b>B</b>	MANUFACTURER	NAME <u>N/A</u>
		ADDRESS <u>N/A</u>
<b>C</b>	FLIGHT	FROM <u>N/A</u>
		TO <u>N/A</u>
<b>D</b>	N- <u>606RN</u> ★	SERIAL NO. <u>006</u>
	BUILDER <u>Raytheon Company</u>	MODEL <u>Cobra</u>
	DATE OF ISSUANCE <u>December 14, 2010</u>	EXPIRY <u>December 14, 2011</u>
	OPERATING LIMITATIONS DATED <u>12/14/10</u>	(ARE PART OF THIS CERTIFICATE)
<b>E</b>	SIGNATURE OF FAA REPRESENTATIVE <i>Bradley Roon</i> Bradley Roon	DESIGNATION OR OFFICE NO. <u>Phoenix MIDO NM-50</u>

Any alteration, reproduction or misuse of this certificate may be punishable by a fine not exceeding \$1,000 or imprisonment not exceeding 3 years, or both. THIS CERTIFICATE MUST BE DISPLAYED IN THE AIRCRAFT IN ACCORDANCE WITH APPLICABLE TITLE 14, CODE OF FEDERAL REGULATIONS (CFR).

<b>A</b>	This airworthiness certificate is issued under the authority of Public Law 104-6, 49 United States Code (USC) 44704 and Title 14 Code of Federal Regulations (CFR).
<b>B</b>	The airworthiness certificate authorizes the manufacturer named on the reverse side to conduct production flight tests, and only production flight tests, of aircraft registered in his name. No person may conduct production flight tests under this certificate: (1) Carrying persons or property for compensation or hire; and/or (2) Carrying persons not essential to the purpose of the flight.
<b>C</b>	This airworthiness certificate authorizes the flight specified on the reverse side for the purpose shown in Block A.
<b>D</b>	This airworthiness certificate certifies that as of the date of issuance, the aircraft to which issued has been inspected and found to meet the requirements of the applicable CFR. The aircraft does not meet the requirements of the applicable comprehensive and detailed airworthiness code as provided by Annex 8 to the Convention On International Civil Aviation. No person may operate the aircraft described on the reverse side: (1) except in accordance with the applicable CFR and in accordance with conditions and limitations which may be prescribed by the Administrator as part of this certificate; (2) over any foreign country without the special permission of that country.
<b>E</b>	Unless sooner surrendered, suspended, or revoked, this airworthiness certificate is effective for the duration and under the conditions prescribed in 14 CFR, Part 21, Section 21.181 or 21.217.



12/20/2011



Phoenix MDO  
17777 N. Perimeter Drive  
Suite 103  
Scottsdale, AZ 85255

### Operating Limitations

#### Experimental: Research and Development, Market Survey, and Crew Training

<b>Registered Owner Name:</b> Raytheon Missile Systems	<b>Aircraft Builder:</b> Raytheon Missile Systems Bldg M09, M/S 5 P.O. Box 11337 Tucson, AZ 85734-1337
<b>Registered Owner Address:</b> Bldg M09, M/S 5 P.O. Box 11337 Tucson, AZ 85734-1337	<b>Year Manufactured:</b> 2006
<b>Aircraft Description:</b> Unmanned, composite, mid-wing monoplane with standard tail surfaces and a tractor engine.	<b>Aircraft Serial Number:</b> 006
<b>Aircraft Registration:</b> N606RN	<b>Aircraft Model Designation:</b> Cobra
	<b>Engine Model:</b> Desert Aircraft DA-150

The following conditions and limitations apply to all unmanned aircraft system (UAS) flight operations for the Raytheon Cobra while operating in the National Airspace System (NAS).

#### 1. General Information.

a. **Integrated system.** For the purposes of this special airworthiness certificate and operating limitations, the Raytheon Cobra operated by Raytheon Missile Systems is considered to be an integrated system. The system is composed of the following:

- (1) Raytheon Missile Systems, Cobra, unmanned aircraft, s/n 006,
- (2) UAS control stations, fixed, mobile, or ground-based,
- (3) Telemetry, launch, and recovery equipment,
- (4) Communications and navigation equipment, including ground and/or airborne equipment used for command and control of the Raytheon Cobra.
- (5) Equipment on the ground and in the air used for communication with other members of the flightcrew, observers, air traffic control (ATC), and other users of the NAS.



**b. Compliance with 14 CFR Part 61 (Certification: Pilots, Flight Instructors, and Ground Instructors) and part 91 (General Operating and Flight Rules).** Unless otherwise specified in this document, the UA pilot-in-command (PIC) and Raytheon Missile Systems must comply with all applicable sections and parts of 14 CFR including, but not limited to, parts 61 and 91.

**c. Operational requirements.**

(1) No person may operate this UAS for other than the purpose of research and development, market survey, and/or crew training, to accomplish the flight operation outlined in the Raytheon Cobra program letter dated 12/15/11, which describes compliance with § 21.193(d), Experimental certificates: General, and has been made available to the UA PIC.

(2) This UAS must be operated in accordance with applicable air traffic and general operating rules of part 91 and all additional limitations herein prescribed under the provisions of § 91.319(i), Aircraft having experimental certificates: Operating limitations.

(3) Raytheon Missile Systems must accumulate at least 50 flight hours under its experimental airworthiness certificate before customer crew training is permitted, in accordance with § 21.195(d), Experimental certificates: Aircraft to be used for market surveys, sales demonstrations, and customer crew training.

**d. UA condition.** The UA PIC must determine that the UA is in a condition for safe operation and in a configuration appropriate for the purpose of the intended flight.

**e. Multiple-purpose operations.** When changing between operating purposes of a multiple purpose certificate, the operator must determine that the aircraft is in a condition for safe operation and appropriate for the purpose intended. A record entry will be made by an appropriately rated person (that is, an individual authorized by the applicant and acceptable to the FAA) to document that finding in the aircraft maintenance records.

**f. Operation exceptions.** No person may operate this UA to carry property for compensation or hire (§ 91.319(a)(2)).

**g. UA markings.**

(1) This UA must be marked with its U.S. registration number in accordance with part 45 or alternative marking approval issued by the FAA Production and Airworthiness Division (AIR-200).

(2) This UA must display the word *Experimental* in accordance with § 45.23(b), Display of marks, unless otherwise granted an exemption from this requirement.

**h. Required documentation.** Before conducting the initial flight of the Cobra UAS, Raytheon Missile Systems must transmit by email a scanned copy of the Raytheon Cobra program letter, special airworthiness certificate, and operating limitations to the following FAA personnel:

(1) Mark Dillon, Air Traffic Control Specialist UAS, FAA Western Service Area, Operations Support Group, AJV-W23, (425)-203-4535, email: [mark.ctr.dillon@faa.gov](mailto:mark.ctr.dillon@faa.gov).

(2) Thomas Rampulla, Transportation Industry Analyst, Production and Airworthiness Division, AIR-200, (202) 385-6684, email: [thomas.rampulla@faa.gov](mailto:thomas.rampulla@faa.gov).

**i. Change in registrant address.** Section 47.45, Change of address, requires that the FAA Aircraft Registry be notified within 30 days of any change in the aircraft registrant's



address. Such notification is to be made by providing AC Form 8050-1, Aircraft Registration Application, to the FAA Aircraft Registration Branch (AFS-750) in Oklahoma City, Oklahoma.

**j. Certificate display and manual availability.** The airworthiness and registration certificates must be displayed, and the aircraft flight manual must be available to the pilot, as prescribed by the applicable sections of 14 CFR, or as prescribed by an exemption granted to Raytheon Missile Systems, in accordance with 14 CFR part 11, General Rulemaking Procedures.

**2. Program Letter.** The Raytheon Cobra program letter, dated 12/08/2011, will be used as a basis for determining the operating limitations prescribed in this document. All flight operations must be conducted in accordance with the provisions of this document.

### **3. Initial Flight Testing.**

**a. Requirements.** Flight operations must be conducted within visual line of sight of the pilot/observer. Initial flight testing must be completed upon accumulation of 25 flight hours. Following satisfactory completion of initial flight testing, the operations manager or chief pilot must certify in the records that the aircraft has been shown to comply with § 91.319(b). Compliance with § 91.319(b) must be recorded in the aircraft records with the following, or a similarly worded, statement:

*I certify that the prescribed flight test hours have been completed and the aircraft is controllable throughout its normal range of speeds and throughout all maneuvers to be executed, has no hazardous operating characteristics or design features, and is safe for operation. The following aircraft operating data has been demonstrated during the flight testing: speeds  $V_x$  \_\_\_\_\_, and  $V_y$  \_\_\_\_\_, and the weight \_\_\_\_\_ and CG location \_\_\_\_\_ at which they were obtained.*

**b. Aircraft operations for the purpose of market surveys, sales demonstrations, and customer crew training.** These operations cannot be performed until 50 flight hours have been accomplished. An entry in the aircraft maintenance records is required as evidence of compliance.

### **4. Authorized Flight Operations Area.**

**a.** The main base of operations for the UA shall be:

Unmanned Vehicles International, Inc  
2595 North Sagebrush Road, Whetstone, AZ  
±4 Miles east of State Route 90 on State Route 82, west of  
Mile Post 56, ½ mile north. on Sagebrush Road  
T20S, R20E, Sec. 3

This is the address of the Cochise County Western Region Landfill. UVI is accessed through the landfill property.

**b.** The flight operations area authorized for the UA is depicted graphically in Figure 2. This area shall be referred to as the Primary Containment Area (PCA). The 25 km arc defines the north east boundary between points 3A and 8A. This arc depicts the limits of the approved FCC frequency range. Raytheon is responsible for notifying the FAA of the breach of any operations area.

**c.** The boundary of the Primary Containment Area is defined by the following coordinates:



- (1) N 31° 44' 00.00" W 110° 20' 30.00"
- (2) N 31° 52' 00.00" W 110° 20' 00.00"
- (3) N 31° 52' 00.00" W 110° 11' 00.00"
- (3A) N 31° 56' .00" W 110° 11' 00.00"
- 25 km ARC from Whetstone -
- (8A) N 31° 45' 00.00" W 110° 02' 00.00"
- (9) N 31° 45' 00.00" W 110° 11' 00.00"
- (10) N 31° 43' 14.00" W 110° 14' 00.00"
- (11) N 31° 42' 00.00" W 110° 19' 30.00"
- (12) N 31° 44' 00.00" W 110° 19' 30.00"
- (13) Return to 1

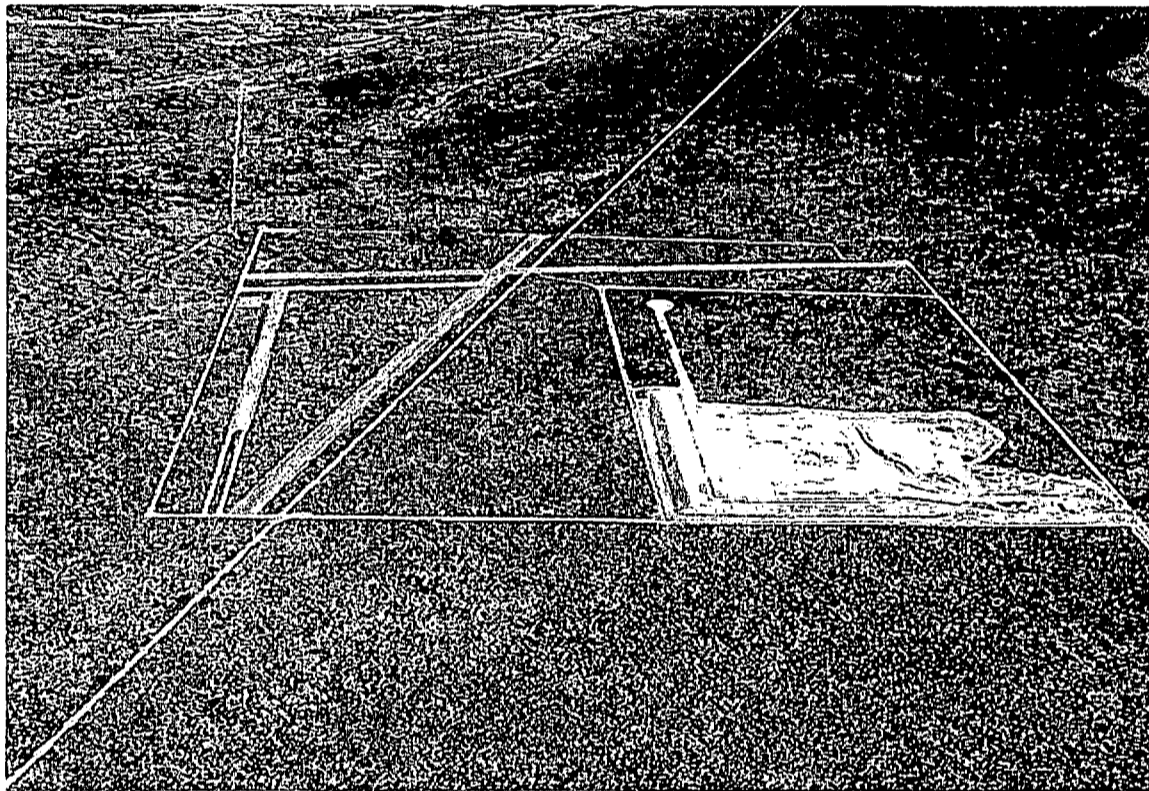
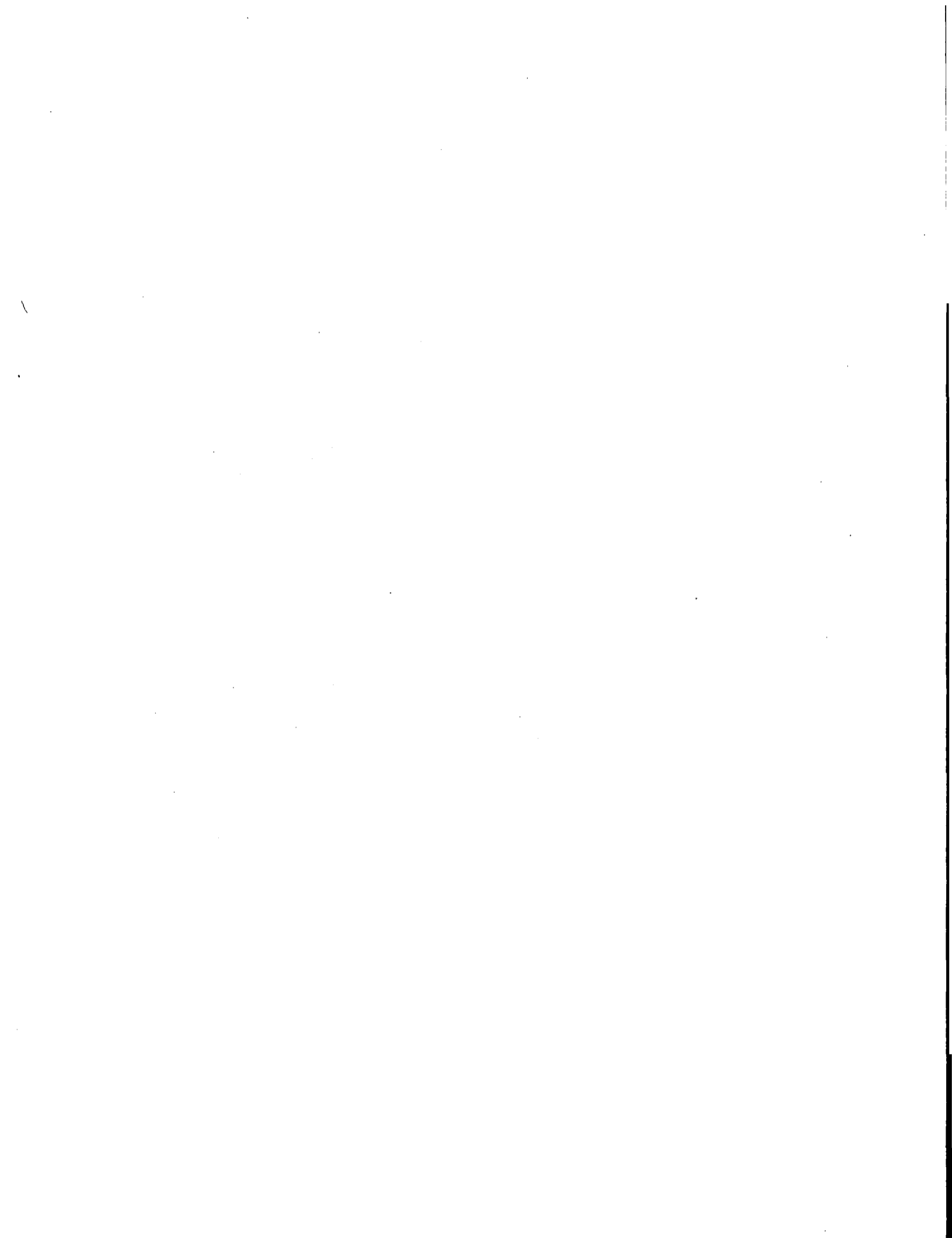

Figure 1. UVI UAS airfield looking north, located next to the Cochise County landfill.





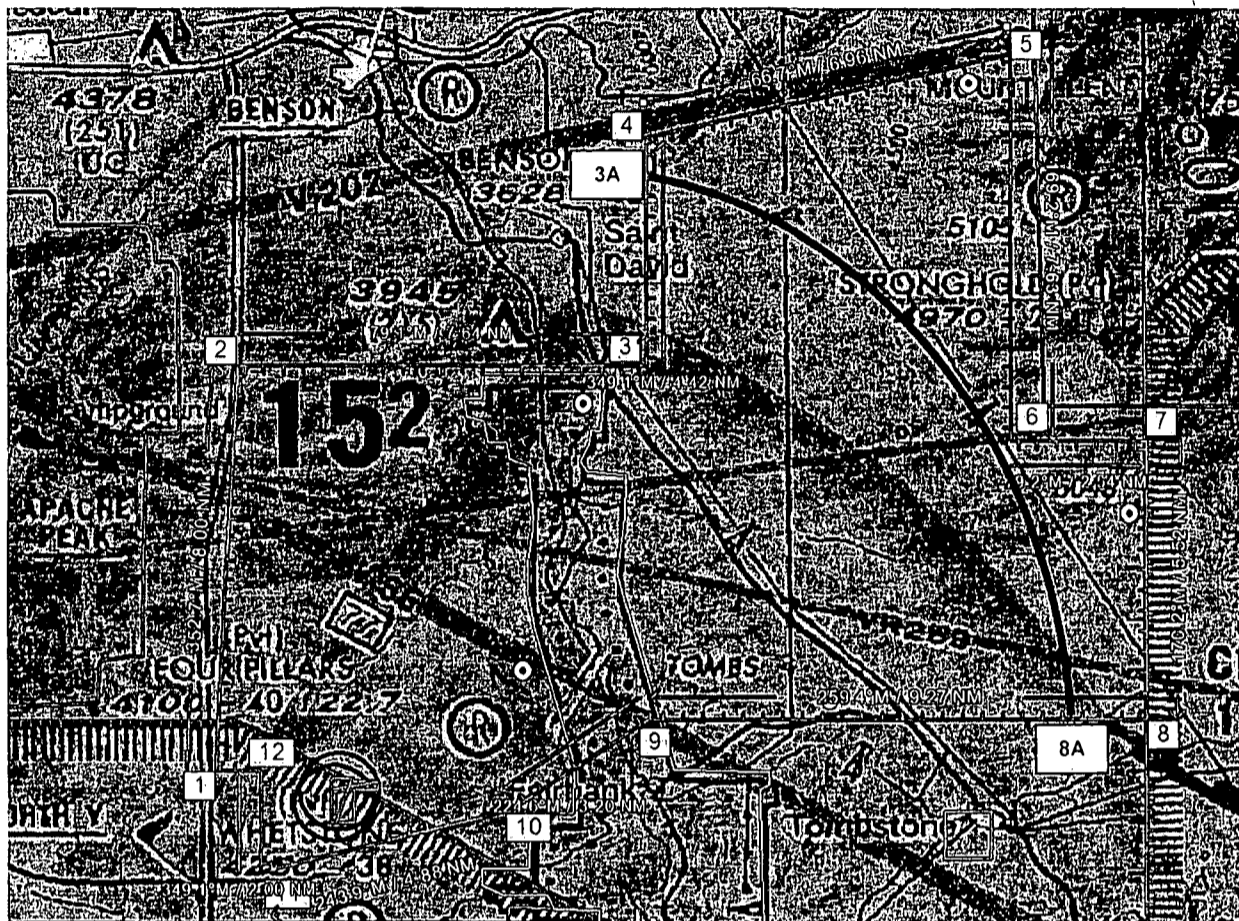

Figure 2. Phoenix Sectional, FHU 004/08.5, 4225' Elevation, N 31° 43' 30", W 110° 17' 47".

**d. Criteria for remaining in the flight test area.** The UAS PIC must ensure all UA flight operations remain within the lateral and vertical boundaries of the primary containment area. **The maximum ceiling for all flight operations is 2000 ft AGL.** The UAS PIC must take into account all factors that may affect the capability of the UA to remain within the primary containment area. This includes, but is not limited to, considerations for wind, gross weight, and glide distances.

**e. Incident/accident reporting.** Any incident/accident and any flight operation that transgresses the lateral or vertical boundaries of the primary containment area must be reported to the FAA within 24 hours. This information must be reported to the Unmanned Aircraft Program Office (UAPO), AFS-407. AFS-407 can be reached by telephone at 202-385-4636 and fax at 202-385-4559. Accidents must be reported to the National Transportation Safety Board (NTSB) per instructions contained on the NTSB Web site: [www.ntsb.gov](http://www.ntsb.gov). Further flight operations must not be conducted until the incident is reviewed by AFS-407 and authorization to resume operations is provided to Raytheon Missile Systems.

## 5. UA Pilots and Observers.

### a. UA PIC roles and responsibilities.

- (1) The UA PIC must perform crew duties for only one UA at a time.

---

---

(2) All flight operations must have a designated UA PIC. The UA PIC has responsibility over each flight conducted and is accountable for the UA flight operation.

(3) The UA PIC is responsible for the safety of the UA as well as persons and property along the UA flight path. This includes, but is not limited to, collision avoidance and the safety of persons and property in the air and on the ground.

(4) The UA PIC must avoid densely populated areas (§ 91.319) and exercise increased vigilance when operating within or in the vicinity of published airway boundaries.

**b. UA PIC certification and ratings requirements.**

(1) The UA PIC must hold and be in possession of, at a minimum, an FAA private pilot certificate, with either an airplane, rotorcraft, or powered-lift category; and single- or multiengine class ratings, appropriate to the type of UA being operated.

(2) The UA PIC must have and be in possession of a valid second-class airman medical certificate issued under 14 CFR part 67, Medical Standards and Certification.

**c. UA PIC currency, flight review, and training.**

(1) No person may act as pilot in command of an unmanned aircraft unless that person has made at least three takeoffs and three landings in manned aircraft within the preceding 90 days acting as the sole manipulator of the flight controls.

(2) The UA PIC must have a flight review in manned aircraft every 24 calendar months in accordance with § 61.56, Flight review.

(3) The UA PIC must maintain currency in unmanned aircraft in accordance with Raytheon Missile Systems company procedures.

(4) The UA PIC must have a flight review in unmanned aircraft every 24 calendar months in accordance with Raytheon Missile Systems company procedures.

(5) All UA PICs must have successfully completed applicable Raytheon Missile Systems training for the UAS.

**d. Supplemental UA pilot roles and responsibilities.**

(1) Any additional UA pilot(s) assigned to a crew station during UA flight operations will be considered a supplemental UA pilot.

(2) A supplemental UA pilot assists the PIC in the operation of the UA and may do so at the same or a different control station as the PIC. The UA PIC will have operational override capability over any supplemental UA pilots, regardless of position.

(3) A supplemental UA pilot must perform crew duties for only one UA at a time.

**e. Supplemental UA pilot certification.**

(1) Supplemental UA pilots must have, at a minimum, successfully completed private pilot ground school, or an FAA recognized equivalent. Additionally, supplemental pilots must have successfully passed the private pilot, commercial pilot, or airline transport pilot knowledge test within the past 24 calendar months. If a supplemental UA pilot assumes the role of PIC, then they must be a certificated pilot and meet the requirements listed above in 5a through 5c.

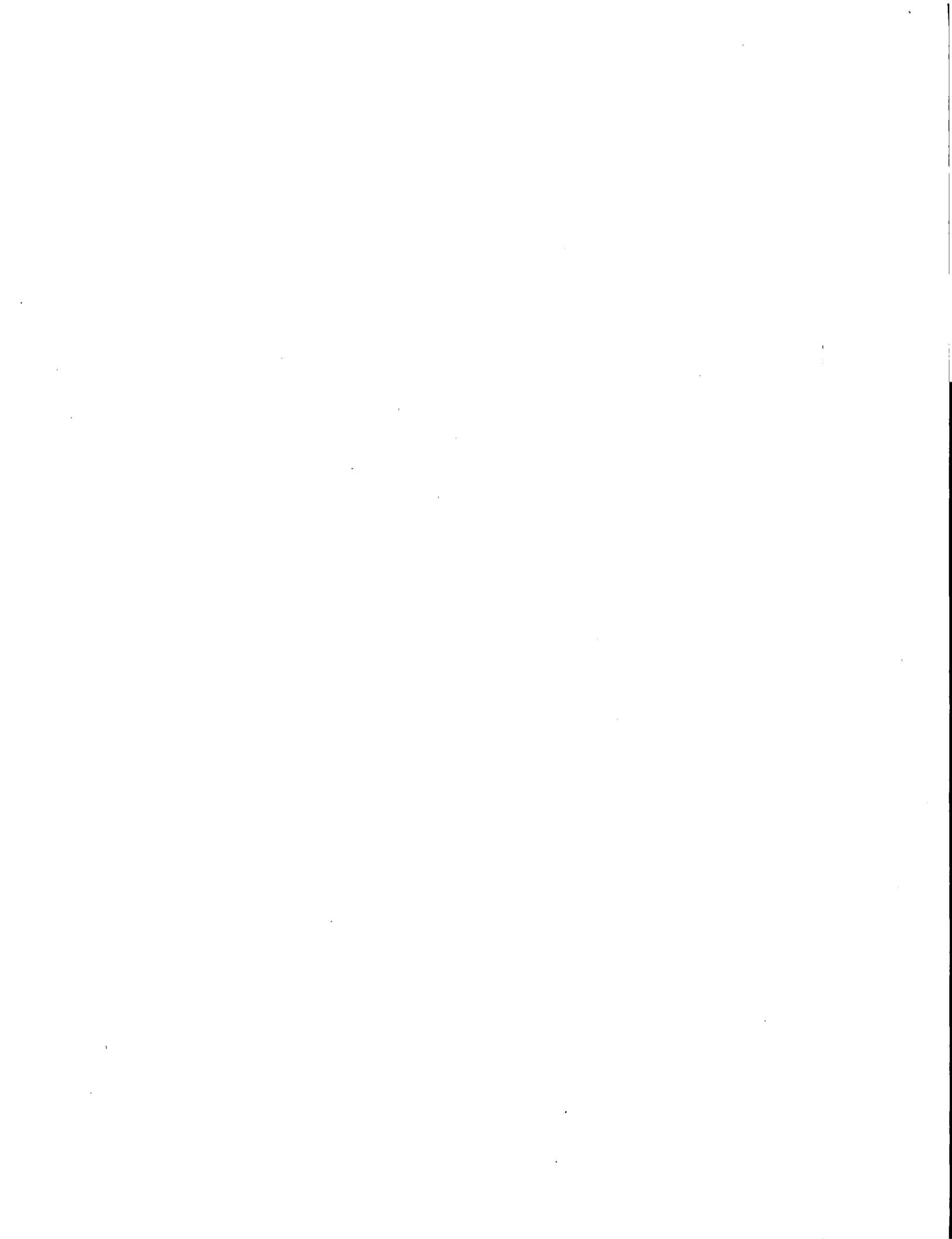

(2) All supplemental pilots must have and be in possession of a valid second-class (or higher) airman medical certificate issued under 14 CFR part 67, Medical Standards and Certification.

**f. Supplemental UA pilot currency, flight review, and training.**

(1) All supplemental UA pilots must maintain currency in unmanned aircraft in accordance with Raytheon Missile Systems company procedures.

(2) All supplemental UA pilots must have a flight review in unmanned aircraft every 24 calendar months in accordance with Raytheon Missile Systems company procedures.

(3) All supplemental UA pilots must have successfully completed applicable Raytheon Missile Systems training for the UAS.

**g. Observer roles and responsibilities.** The task of the observer is to provide the UA PIC(s) with instructions to maneuver the UA clear of any potential collision with other traffic. To satisfy these requirements:

(1) The observer must perform crew duties for only one UA at a time.

(2) At no time will the observer permit the UA to operate beyond the line-of-sight necessary to ensure maneuvering information can be reliably determined.

(3) In order to comply with the see and avoid requirements of Title 14 of the Code of Federal Regulations sections 91.113 and 91.111, the pilot-in-command and visual observers must be able to see the aircraft and the surrounding airspace throughout the entire flight; and be able to determine the aircraft's altitude, flight path and proximity to traffic and other hazards (terrain, weather, structures) sufficiently to exercise effective control of the aircraft to give right-of-way to other aircraft, and to prevent the aircraft from creating a collision hazard.

(4) An observer must maintain continuous visual contact with the UA to discern UA attitude and trajectory in relation to conflicting traffic.

(5) Observers must continually scan the airspace for other aircraft that pose a potential conflict.

(6) All flight operations conducted in the primary containment area must have an observer to perform traffic avoidance and visual observation to fulfill the see-and-avoid requirement of § 91.113, Right-of-way rules: Except water operations.

(7) If the chase aircraft is operating more than 100 feet above/below and/or ½ nm laterally, of the UA, the chase aircraft PIC will advise the controlling ATC facility.

**h. Observer certification.**

(1) All observers must either hold, at a minimum, an FAA private pilot license or must have successfully completed specific observer training acceptable to the FAA. An observer does not require currency as a pilot.

(2) All observers must have in their possession a valid second-class airman medical certificate issued under part 67.

**i. Observer training.**

(1) All observers must be thoroughly trained, be familiar with, and possess operational experience with the equipment being used. Such training is necessary for observation and detection of other aircraft for collision avoidance purposes as outlined in the Raytheon Cobra program letter.



(2) All observers must have successfully completed applicable Raytheon Missile Systems training for the UAS.

#### **6. Equipage.**

a. The UAS must be equipped with an operable transponder with Mode C or Mode S, and two-way communications equipment allowing communications between the UA pilot, observers, all UAS control stations, and ATC.

b. The UA and chase aircraft must be equipped with operable navigation, position, and/or strobe/anti-collision lights. Strobe/anti-collision lights must be illuminated during all operations.

#### **7. Communications.**

##### **a. Before UA flights.**

(1) Before conducting operations, the frequency spectrum used for operation and control of the UA must be approved by the Federal Communications Commission or other appropriate government oversight agency.

(2) Raytheon shall select and transmit transponder code 1200 unless otherwise directed by Air Traffic Control (ATC). When required, the chase aircraft will also squawk 1200, unless otherwise directed by ATC. Upon initial contact with ATC, the UA PIC must indicate the experimental nature in accordance with § 91.319. Raytheon will advise Libby ATC on frequency 127.05, or by telephone (520-538-9141), when flight ops are terminated for the day (if prior to the end of published NOTAM period).

##### **b. During UA flights.**

(1) Appropriate air traffic frequencies must be monitored during flight operations.

(2) All UA positions must maintain two-way communications with each other during all operations. If unable to maintain two-way communication, the UA PIC will expeditiously return the UA to its base of operations while remaining within the flight test area and conclude the flight operation.

(3) To ensure deconfliction with VR-259 contact the 162<sup>nd</sup> Fighter Wing (FW) Command Post at (520) 295-6371 on the day of, but prior to flight with the location, altitude and NOTAM number. The 162<sup>nd</sup> FW will in turn notify the 162<sup>nd</sup> Supervisor of Flying (SOF) at (520) 295-6014.

#### **8. Flight Conditions.**

a. **Daylight operations.** All flight operations must be conducted during daylight hours in visual meteorological conditions (VMC). Class E cloud clearance minimums will be used for all flight operations in the primary containment area. Flight operation in instrument meteorological conditions (IMC) is not permitted.

##### **b. Prohibitions.**

(1) The UA is prohibited from aerobatic flight, that is, an intentional maneuver involving an abrupt change in the UA's attitude, an abnormal acceleration, or other flight action not necessary for normal flight. (See § 91.303, Aerobatic flight.)

(2) Flight operations must not involve carrying hazardous material or the dropping of any objects or external stores.

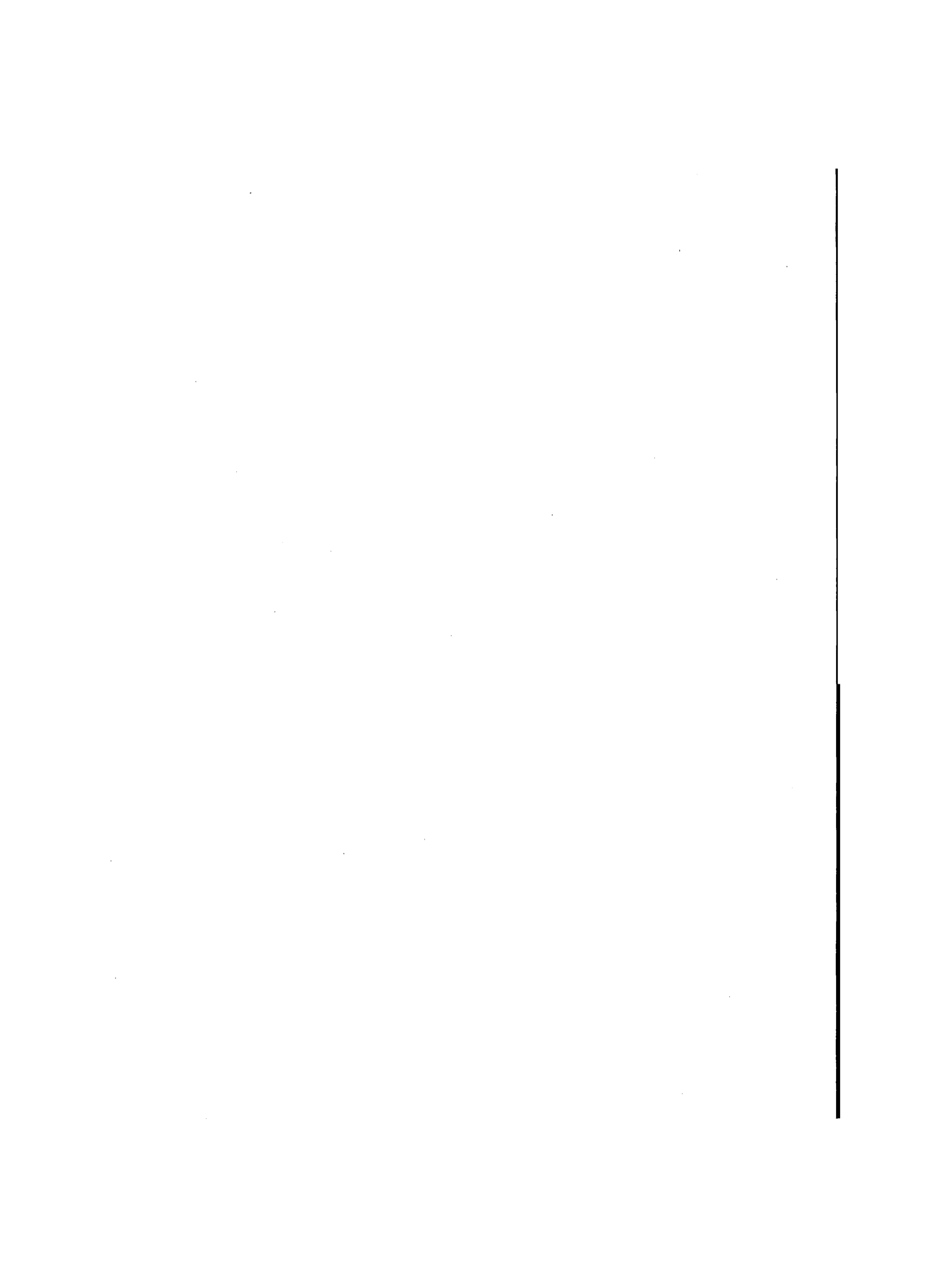



(3) No individual control station may be used to operate more than one UA at one time.

**c. Transponder requirements.** The UA must operate an approved operational Mode C or Mode S altitude encoding transponder during all flight operations.

**d. Transponder failure.** In the event of transponder failure, the UA must conclude all flight operations and expeditiously return to its base of operations within the prescribed limitations of this authorization.

**e. Notice to airman.** Raytheon Missile Systems must request the issuance of a Notice to Airman (NOTAM) through the appropriate FAA Automated Flight Service Station at least 24 hours before flight operation.

#### **9. Flight Termination and Lost Link Procedures.**

**a. Flight termination.** In accordance with Raytheon Cobra program letter, dated 12/08/11, flight operations must be discontinued at any point that safe operation of the UA cannot be maintained or if hazard to persons or property is imminent.

**b. Lost link procedures.** In the event of lost link, the UA must provide a means of automatic recovery that ensures airborne operations are predictable and that the UA remains within the primary containment area. The observer, all other UAS control stations, and the appropriate ATC facility will be immediately notified of the lost link condition and the expected UA response.

#### **10. Maintenance and Inspection.**

**a. General requirements.** The UAS must not be operated unless it is inspected and maintained in accordance with the FAA-approved Cobra UAS Inspection Program, dated 04/21/2008, or later approved FAA revision. Raytheon Missile Systems must establish and maintain aircraft maintenance records (see paragraph 10(d) below).

**b. Inspections.** No person may operate this UAS unless within the preceding 12 calendar months unless it has had a condition inspection performed according to the Cobra UAS Inspection Program, dated 04/21/2008. The UAS must also have been found to be in a condition for safe operation. This inspection will be recorded in the UAS maintenance records as described in paragraph 10(d) below.

**c. Authorized inspectors.** Only those individuals trained and authorized by Raytheon Missile Systems and acceptable to the FAA may perform the inspections and maintenance required by these operating limitations.

**d. Maintenance and inspection records.** Maintenance and inspections of the UAS must be recorded in the UAS maintenance records. The following information must be recorded:

(1) Maintenance record entries must include a description of the work performed, the date of completion for the work, the UAS's total time-in-service, and the name and signature of the person performing the work.

(2) Inspection entries must contain the following, or a similarly worded, statement: *I certify that this UAS was inspected on (date), in accordance with the scope and detail of the Raytheon Missile Systems Cobra UAS Inspection Program, and was found to be in a condition for safe operation.*

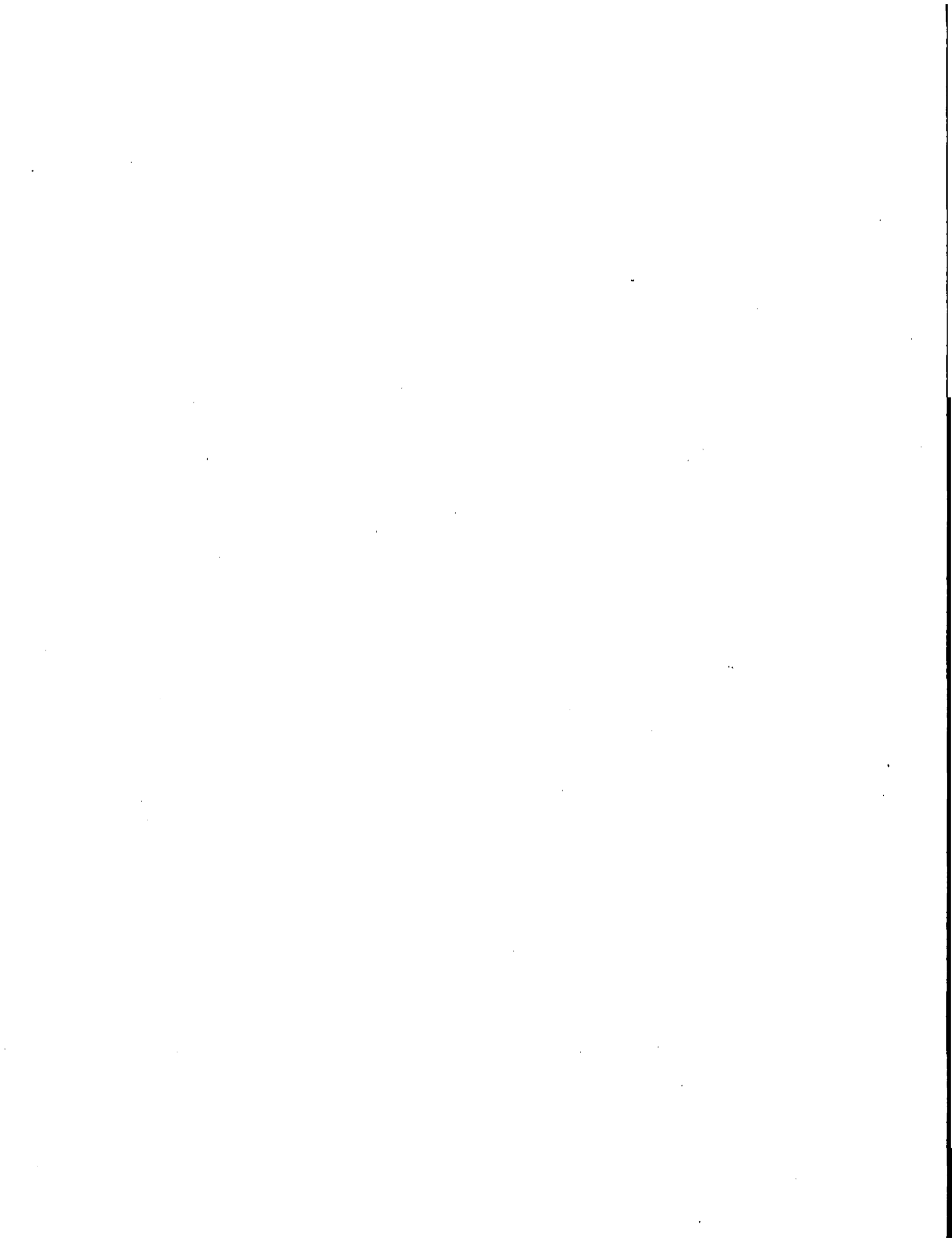

(3) UAS instruments and equipment required to be installed must be inspected and maintained in accordance with the requirements of the Raytheon Missile Systems Cobra UAS Inspection Program. Any maintenance or inspection of this equipment must be recorded in the UAS maintenance records.

(4) No person may operate this UAS unless the altimeter system and transponder have been tested within the preceding 24 calendar months in accordance with § 91.413, ATC transponder tests and inspections. These inspections will be recorded in the UAS maintenance records.

**11. Information Reporting.** Raytheon Missile Systems will provide the following information on a monthly basis, via email, to Mr. Donald Grampp of the FAA UAPO. Mr. Grampp's email address is [donald.e.grampp@faa.gov](mailto:donald.e.grampp@faa.gov). A copy of the report shall be provided to AIR-200.

- a. Number of flights conducted under this certificate.
- b. Pilot duty time per flight.
- c. Unusual equipment malfunctions (hardware or software).
- d. Deviations from ATC instructions.
- e. Unintended entry into lost link flight mode that results in a course change.

**12. Revisions and Other Provisions.**

**a. Experimental certificates, program letters, and operating limitations.** The experimental certificate, FAA-accepted Raytheon Missile Systems program letter, and operating limitations cannot be reissued, renewed, or revised without application being made to the Phoenix Manufacturing Inspection District (MIDO), in coordination with AIR-200. AIR-200 will be responsible for FAA Headquarters internal coordination with the Aircraft Certification Service, Flight Standards Service, Air Traffic Organization, Office of the Chief Council, and Office of Rulemaking.

**b. Certificates of waiver or authorization.** The Production and Airworthiness Division, AIR-200 and the Phoenix MIDO shall be notified immediately if there is any plan for requesting a Certificate of Authorization or Waiver (COA) for UAS operations during the time period the Experimental Certificate is in effect. If the aircraft is authorized to operate under a COA, Raytheon must determine that the aircraft is in a condition for safe operation and appropriately configured for the purpose intended. A record entry will be made by an appropriately rated person to document that finding in the aircraft logbook.

**c. Amendments and cancellations.** The provisions and limitations annotated in this operational approval may be amended or cancelled at any time as deemed necessary by the FAA.

**d. Reviews of revisions.** All revisions to Raytheon Missile Systems FAA-approved Inspection Program must be reviewed and accepted by the Scottsdale Flight Standards District Office.

**13. UAS Modifications.**

**a. Software and system changes.** All software and system changes will be documented as part of the normal maintenance procedures and will be available for inspection. All software and system changes must be inspected and approved per FAA-approved Cobra UAS Inspection Program, dated 04/21/2008. All software changes to the aircraft and control station are categorized as major changes, and must be provided to AIR-200 in summary form at the time they are incorporated.

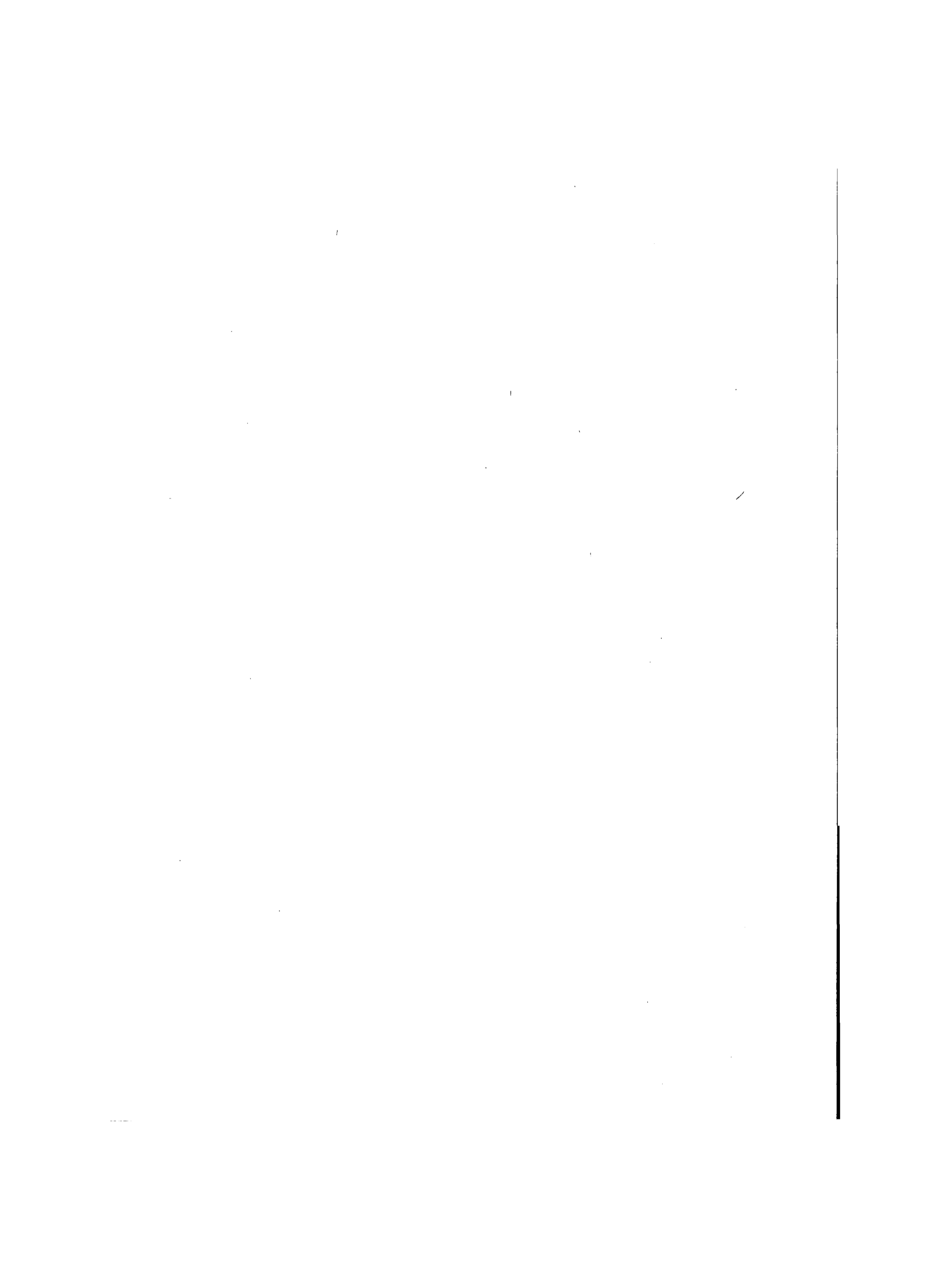

12/20/2011

**b. Major modifications.** All major modifications, whether performed under the experimental certificate, COA, or other authorizations, that could potentially affect the safe operation of the system, must be documented and provided to the AIR-200 before operating the aircraft under this certificate. Major modifications incorporated under COA or other authorizations need to be provided only if the aircraft is flown under these authorizations during the effective period of the experimental certificate.

End of Limitations

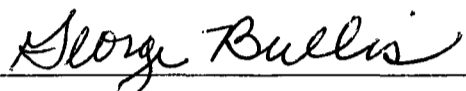

George Bullis  
Aviation Safety Inspector  
Phoenix MIDO  
17777 N. Perimeter Drive  
Suite 103  
Scottsdale, AZ 85255

Date: 12/20/2011

**The Special Airworthiness Certificate and accompanying Operating Limitations expire on December 19, 2012.**

**I certify that I have read and understand the operating limitations, and conditions, that are a part of the Special Airworthiness Certificate; FAA Form 8130-7 issued on December 20, 2011, for the purpose of Research and Development, Market Survey, and/or Crew Training.**

**This Special Airworthiness Certificate is issued for the Raytheon Missile Systems, UA model "Cobra," serial number 006, registration number N606RN.**

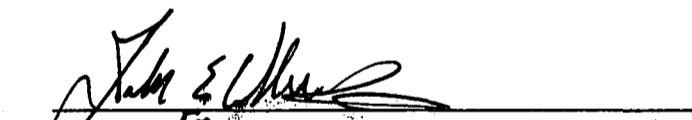

Applicant: Donald L. Newman  
Title: Director, Unmanned Systems  
Company: Raytheon Missile Systems

Date: 12/20/2011

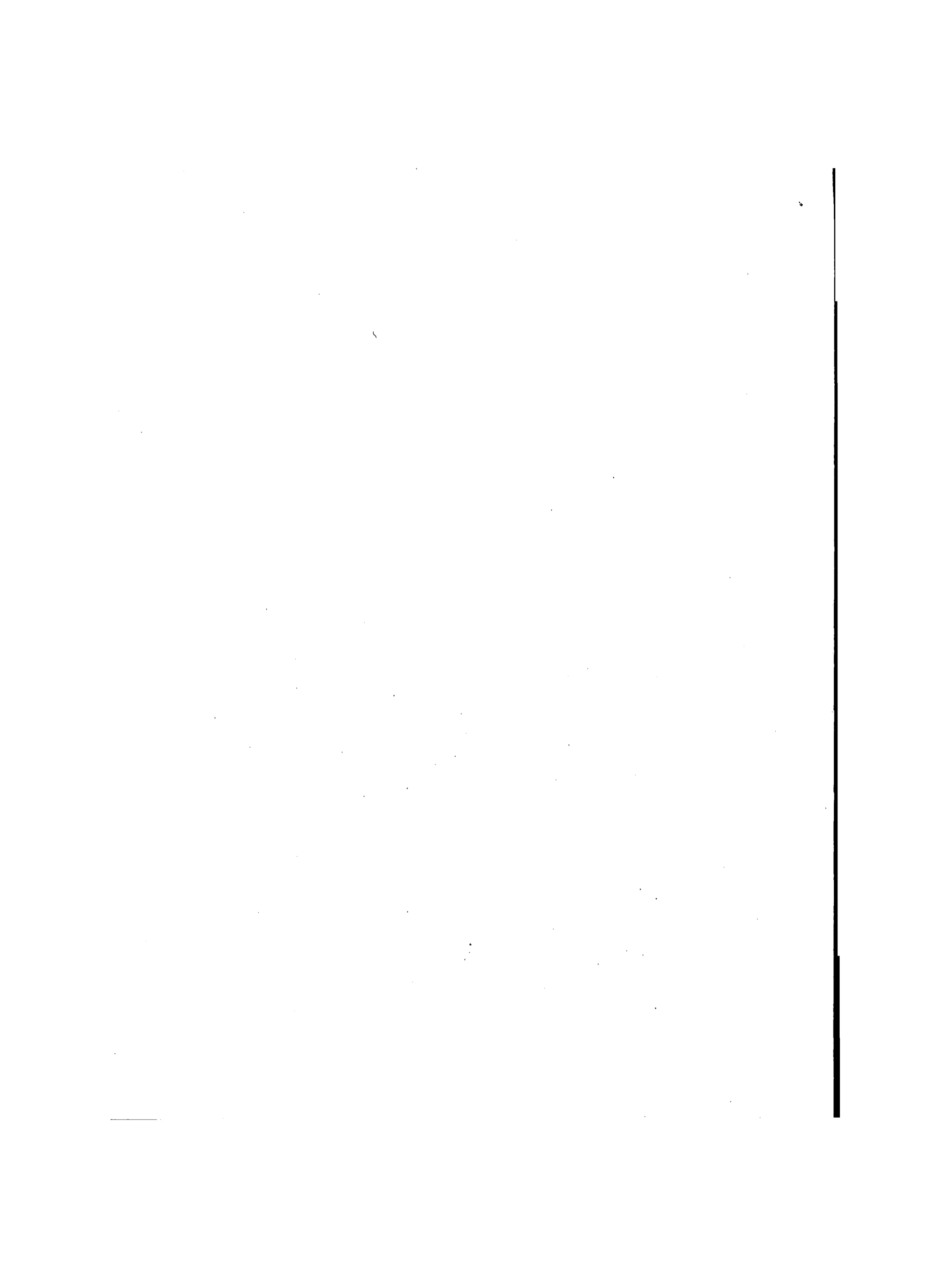

**Raytheon**

# **Raytheon**

Program Letter for Unmanned Aircraft Systems,  
Experimental Airworthiness Certificate

Cobra UAS

(N603RN, N604RN, N606RN, N607RN, N608RN)

Document ID: UNM-01-RR99818

Rev 7, 12-015-11

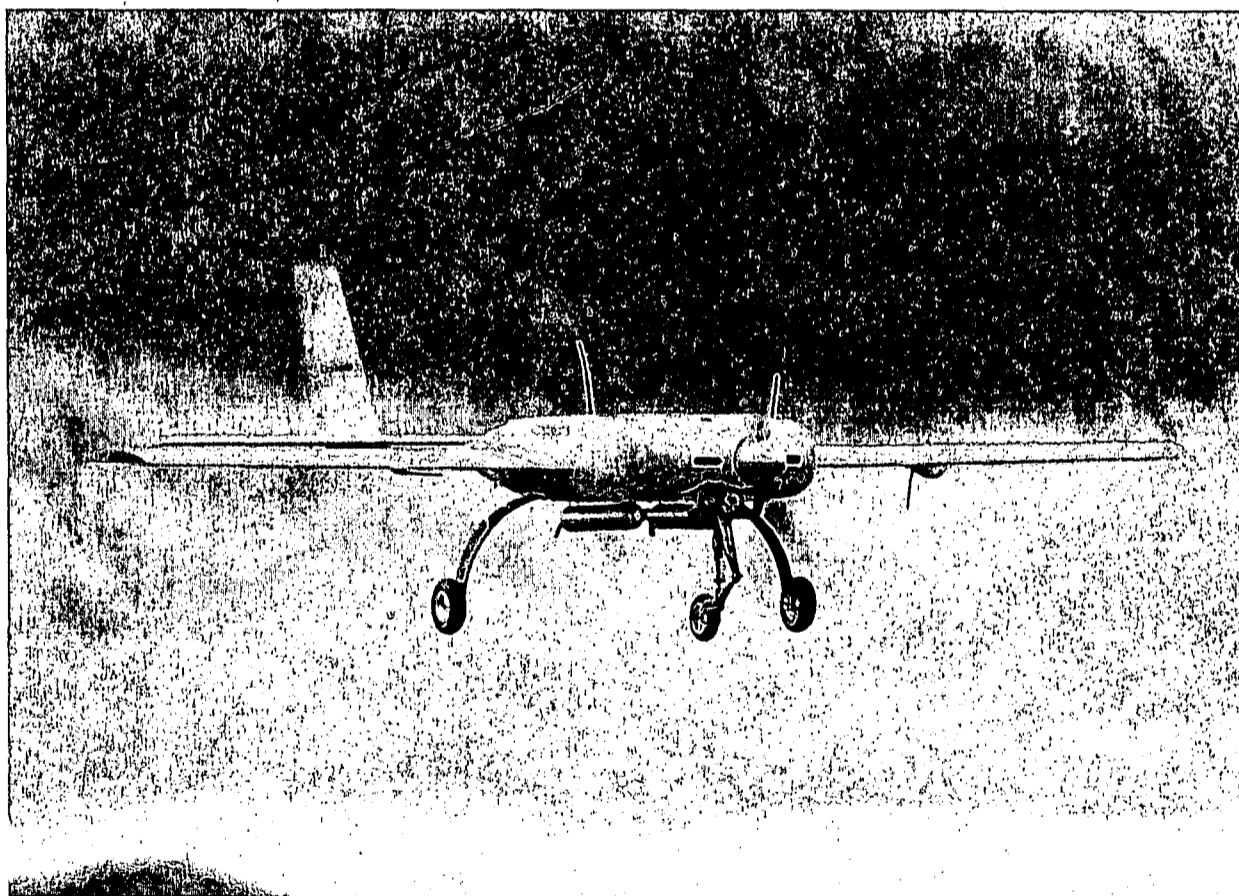

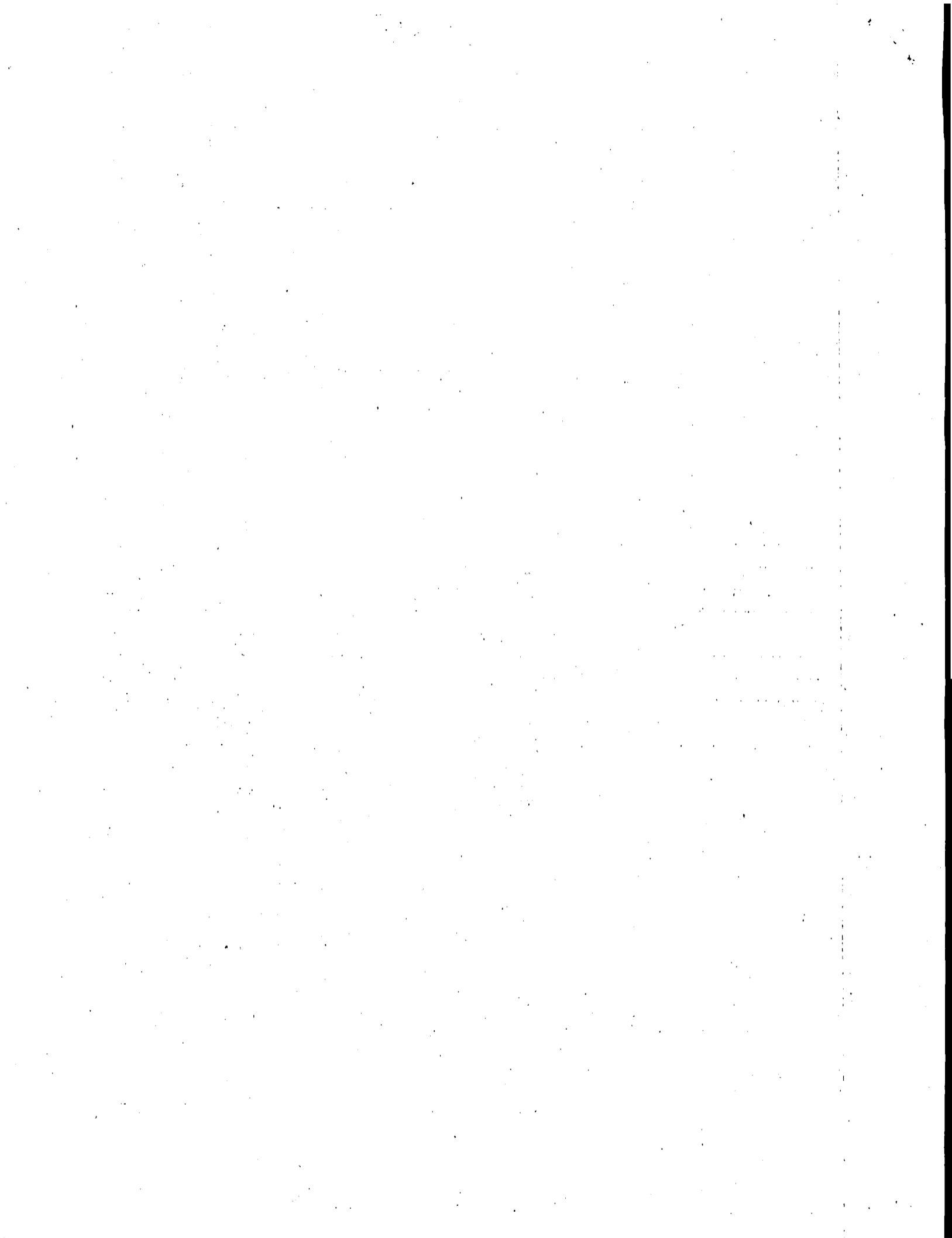



**Revision History**

<b>Revision No.</b>	<b>Description of Change</b>	<b>Date</b>	<b>Revised By</b>
Rev -	Original Document	02/21/07	
Rev 1	2 <sup>nd</sup> Year, Update Altitude, Pilot Data	09/27/07	MDB
Rev 2	USAFA Addition, Max Gross Wt, Prop	06/30/08	MDB
Rev 3	Annual Update, Fig. 8 Flight Termination options updated to current software	09/30/08	DNR
Rev 4	Annual Update	9/30/09	MDB
Rev 5	Annual Update	9/20/10	GLG
Rev 6	Annual Update	11/07/11	GLG
Rev 7	Combine all Program Letters into one	12/15/11	GLG

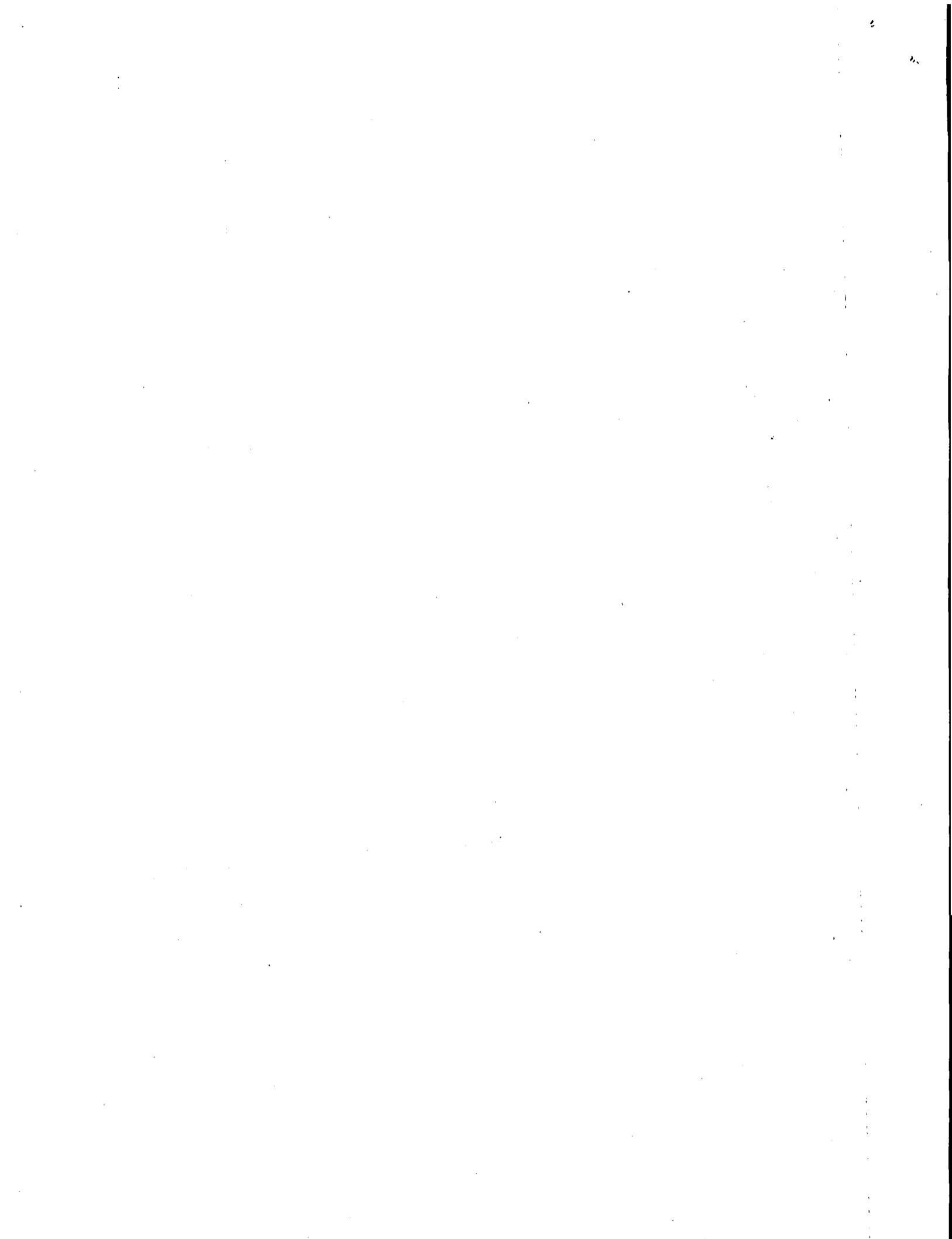

## Table of Contents

<b>Aircraft Specifications</b>	<b>1</b>
<b>1. Define the experimental purpose(s) under which the aircraft is to be operated (14 CFR § 21.191)</b>	<b>2</b>
<b>2. Describe the purpose/scope of the experimental program for each 14 CFR § 21.191 experimental purpose sought (14 CFR § 21.193(b)(d))</b>	<b>2</b>
<b>3. Define the area(s) in which the experimental flights will be conducted</b>	<b>3</b>
<b>4. Aircraft Configuration</b>	<b>8</b>
<b>5. Inspection And Maintenance (14 CFR 91.7)</b>	<b>12</b>
<b>6. Pilot Qualification (14 CFR §§ 61.3, 61.5)</b>	<b>13</b>
<b>7. Aircraft Marking (14 CFR § 45)</b>	<b>15</b>
<b>8. ATC Transponder and Altitude Reporting System Equipment and Use (14 CFR § 91.215)</b>	<b>15</b>
<b>9. Method for See and Avoid (14 CFR § 91.113a)</b>	<b>16</b>
<b>10. Safety Risk Management</b>	<b>16</b>
<b>11. System Configuration</b>	<b>17</b>
<b>12. System Safety – Flight Termination and Lost Link</b>	<b>17</b>
<b>13. Command and Control</b>	<b>19</b>
<b>14. Control Stations</b>	<b>20</b>
<b>15. Control Frequencies</b>	<b>21</b>
<b>Appendix A - Cobra Drawings and Photographs</b>	<b>23</b>
<b>Appendix B - Cloud Cap Piccolo II Users Guide</b>	<b>24</b>
<b>Appendix C - Raytheon UAS Flight Manual</b>	<b>25</b>
<b>Appendix D - Cobra Weight and Balance</b>	<b>25</b>
<b>Appendix E - Minimum Equipment List</b>	<b>26</b>
<b>Appendix F - System Configuration Diagram</b>	<b>30</b>
<b>Appendix G - FAA UAS Safety Checklist</b>	<b>33</b>
<b>Appendix H – Acronym List</b>	<b>34</b>

## Table of Figures

<b>Figure: 1 Cobra UAS</b>	<b>2</b>
<b>Figure: 2 UVI Airfield</b>	<b>4</b>
<b>Figure: 3 UVI Containment Area</b>	<b>Error! Bookmark not defined.</b>
<b>Figure: 4 Cobra 3 View Drawing</b>	<b>8</b>
<b>Figure: 5 MVCS CUCS</b>	<b>11</b>
<b>Figure: 6 Piccolo Flight Termination Settings</b>	<b>18</b>

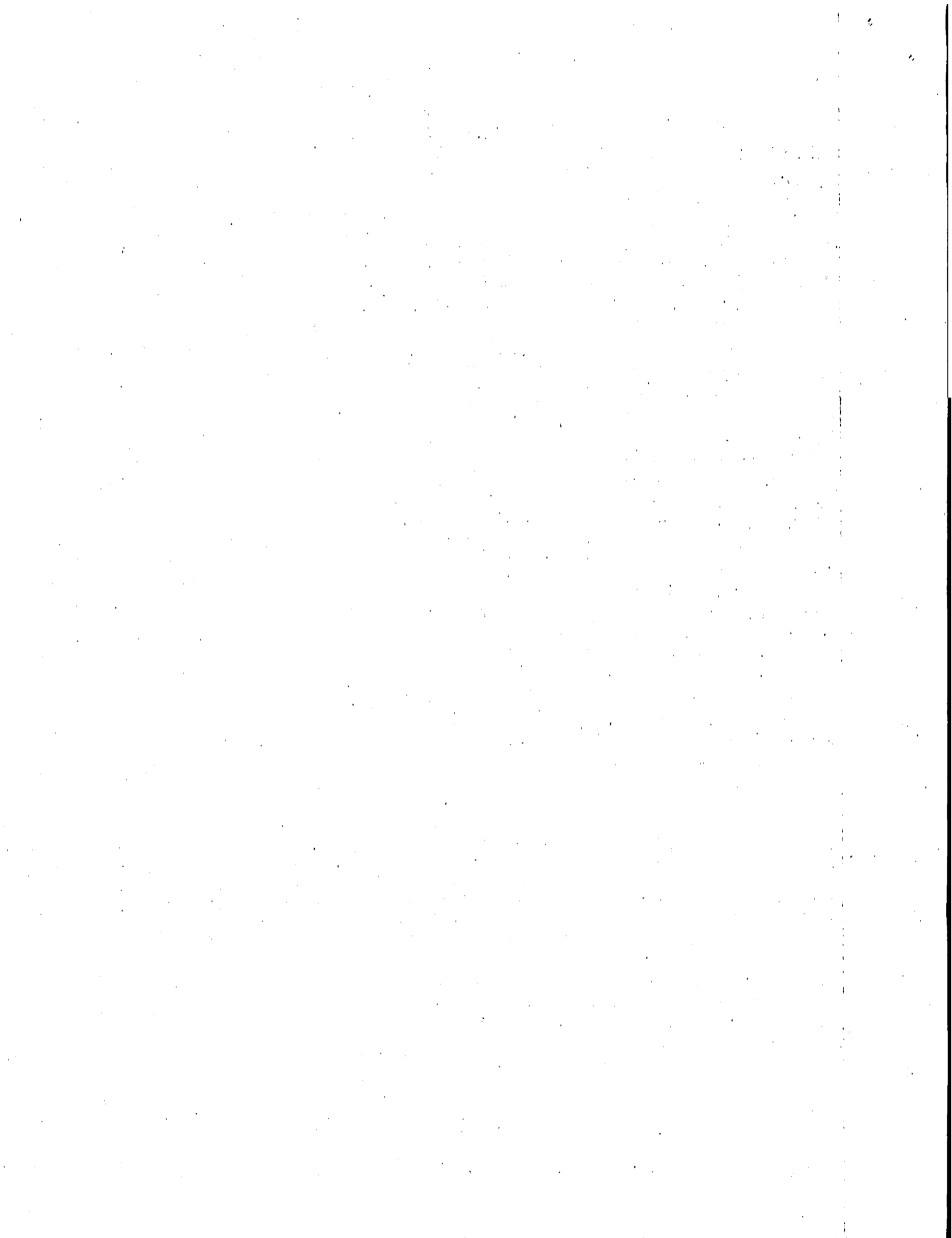

# Raytheon

## Aircraft Specifications

**Registered Owner Name:**  
Raytheon Company

**Registered Owner Address:**  
Raytheon Missile Systems  
Bldg M09, M/S 5  
P.O. Box 11337  
Tucson, AZ 85734-1337

### Aircraft Description:

The aircraft is an unmanned, composite, mid-wing monoplane with standard tail surfaces and a tractor engine. The vertical and horizontal stabilizers are attached to a composite tail boom. The control surfaces consist of full span flaperons, elevator and rudder. The landing gear is tricycle type with a steerable nosewheel, and the main landing gear is equipped with pneumatic brakes. The engine is a 16 hp, air-cooled, 2-cycle, 2 cylinder, opposed, and carbureted powerplant with an electronic ignition system, using gasoline with a 100:1 2-cycle oil mix. Primary electrical power comes from a 500 watt generator with a 180 watt regulator. A Lithium Polymer rechargeable battery provides backup electrical power for 1 hour in the case of main power source failure. As a prototype airframe, Raytheon expects that there will be slight design changes based on the data collected from the initial test flights.

### Aircraft Registration:

This will be an Experimental Aircraft Registration.

Unless otherwise specified in the certificate, the aircraft will be marked on the aft fuselage surface using the N12345 format. 3" lettering will be used due to the small size of the aircraft. The word "Experimental" will be displayed on the fuselage over the wing in ½" letters.

**Aircraft Builder:**  
Raytheon Missile Systems

**Aircraft S/N and Year Manufactured:**  
S/N 003 - 2006  
S/N 004 - 2006  
S/N 006 - 2006  
S/N 007 - 2006  
S/N 008 - 2008  
(Update serial number for each application)

**Aircraft Registration Number:**  
N603RN, N604RN, N606RN,  
N607RN, N608RN

**Aircraft Model Designation:**  
Cobra

**Engine Model:**  
Desert Aircraft DA-150  
[http://www.desertaircraft.com/engines\\_detail.php?Page=DA-150](http://www.desertaircraft.com/engines_detail.php?Page=DA-150)

**Fuel:**  
87-91 Octane Gasoline  
OR  
100 Octane Aviation Fuel

**Oil:**  
Saber™ Professional Synthetic 100:1 Pre-Mix 2-Cycle Oil (ATP)  
<http://www.amsoil.com/storefront/atp.aspx>

**Propeller Model:**  
Mejzlik 28 x 12 -3b; 28 x 12 W-3b; 30 x 12  
<http://mejzlikmodellbau.inshop.cz>

Air Models 28 x 12 -3b

7

2

6

[Faint, illegible text covering the majority of the page, possibly bleed-through from the reverse side.]

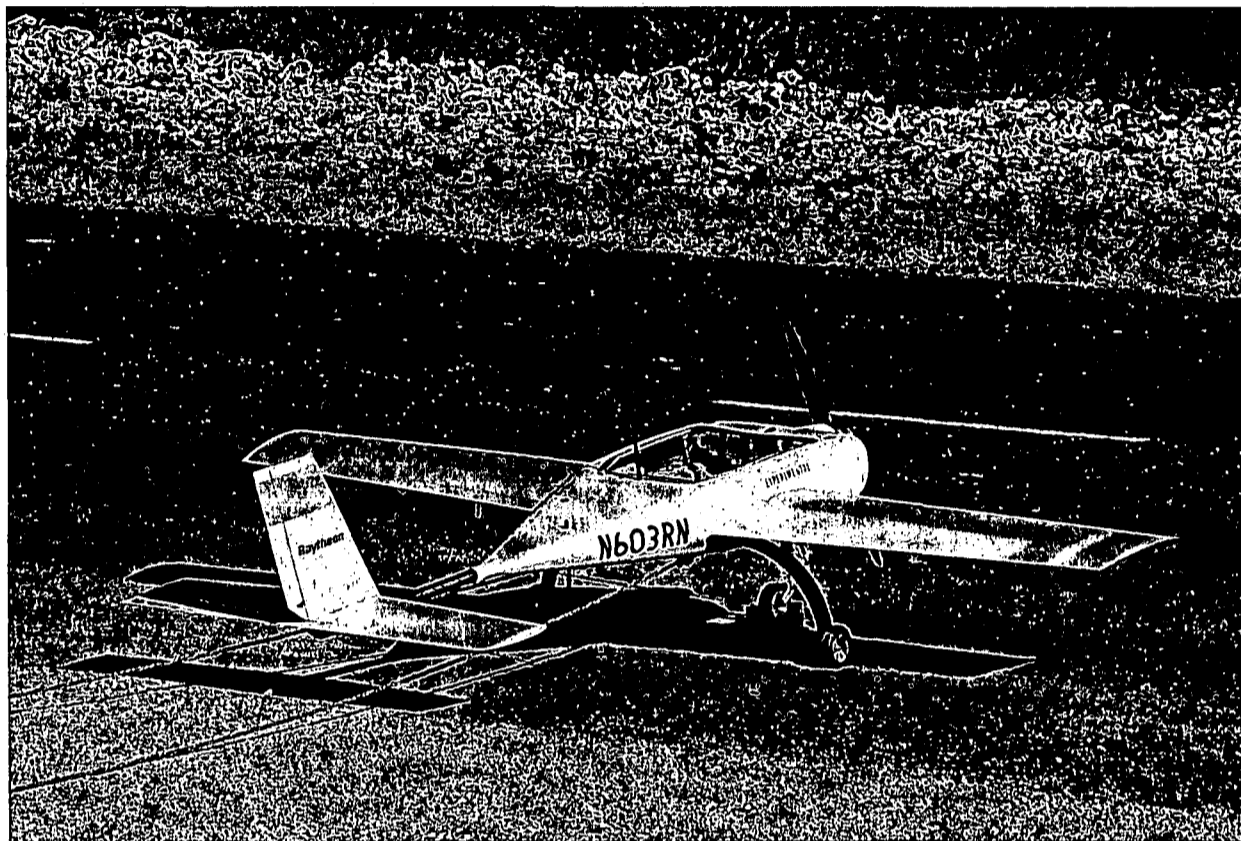

Figure: 1 Cobra UAS

**1. Define the experimental purpose(s) under which the aircraft is to be operated (14 CFR § 21.191)**

*Research and development.* Testing new unmanned aircraft design concepts, avionics and ground equipment, Command and Control Systems, installations, operating techniques, and new uses for unmanned aircraft.

*Crew training.* Training of the Raytheon Company flight crews.

*Market surveys.* Use of UAS for purposes of conducting market surveys, sales demonstrations, and customer crew training only as provided in §21.195.

**2. Describe the purpose/scope of the experimental program for each 14 CFR § 21.191 experimental purpose sought. (14 CFR § 21.193(b)(d))**

*Research and development* – This unmanned aircraft will be used as a test bed for data links, sensors, processors, autopilots, “sense and avoid” and other electronics/avionics as required to meet the Raytheon Company business goals.

*Crew training* – Flights will be conducted by qualified Raytheon UAS pilots. Aircraft checkout and regular proficiency training will be conducted to meet the Raytheon

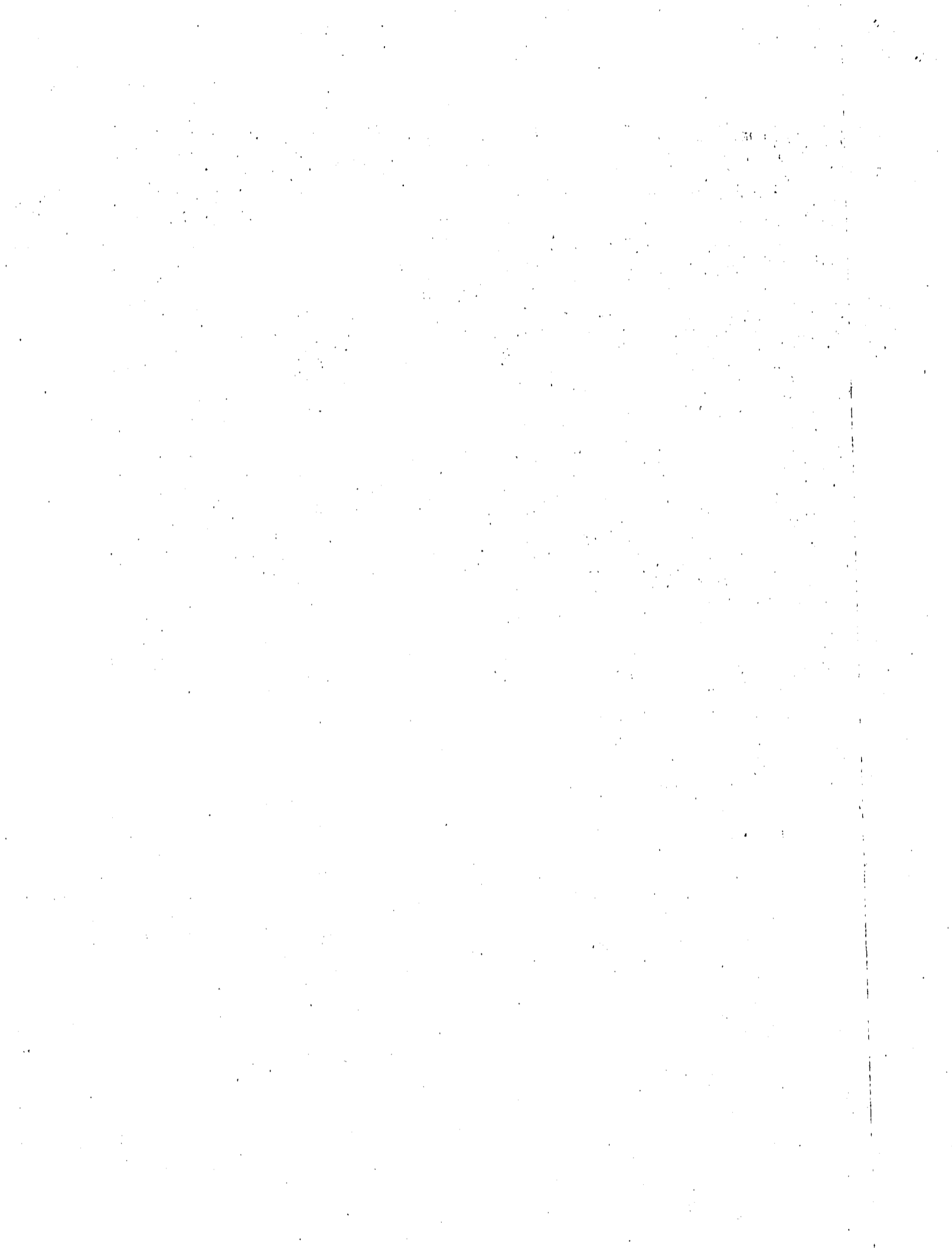



# Raytheon

Company flight testing requirements. Upon customer request, flight training of a customer pilot will occur.

A training program will be submitted as a separate document.

*Market surveys* – This aircraft will be used to demonstrate the concepts, electronics and avionics listed above to various public customers. The demonstration of the Cobra UAS will only be conducted at the site approved under the experimental airworthiness certificate.

### 3. Define the area(s) in which the experimental flights will be conducted

- Describe the areas over which the flights are to be conducted and address of base operation (14 CFR § 21.193(d)(3)).

#### SOUTHERN ARIZONA

Raytheon leases a new facility built specifically by Unmanned Vehicles International (UVI) Inc. (<http://www.uviinc.com/>) to operate UAS near Sierra Vista, AZ.

Unmanned Vehicles International, Inc  
633 Wilcox Drive  
Sierra Vista, Arizona 85635  
520-458-4212

Raytheon has been using this facility for local UAS operations since April 2005.

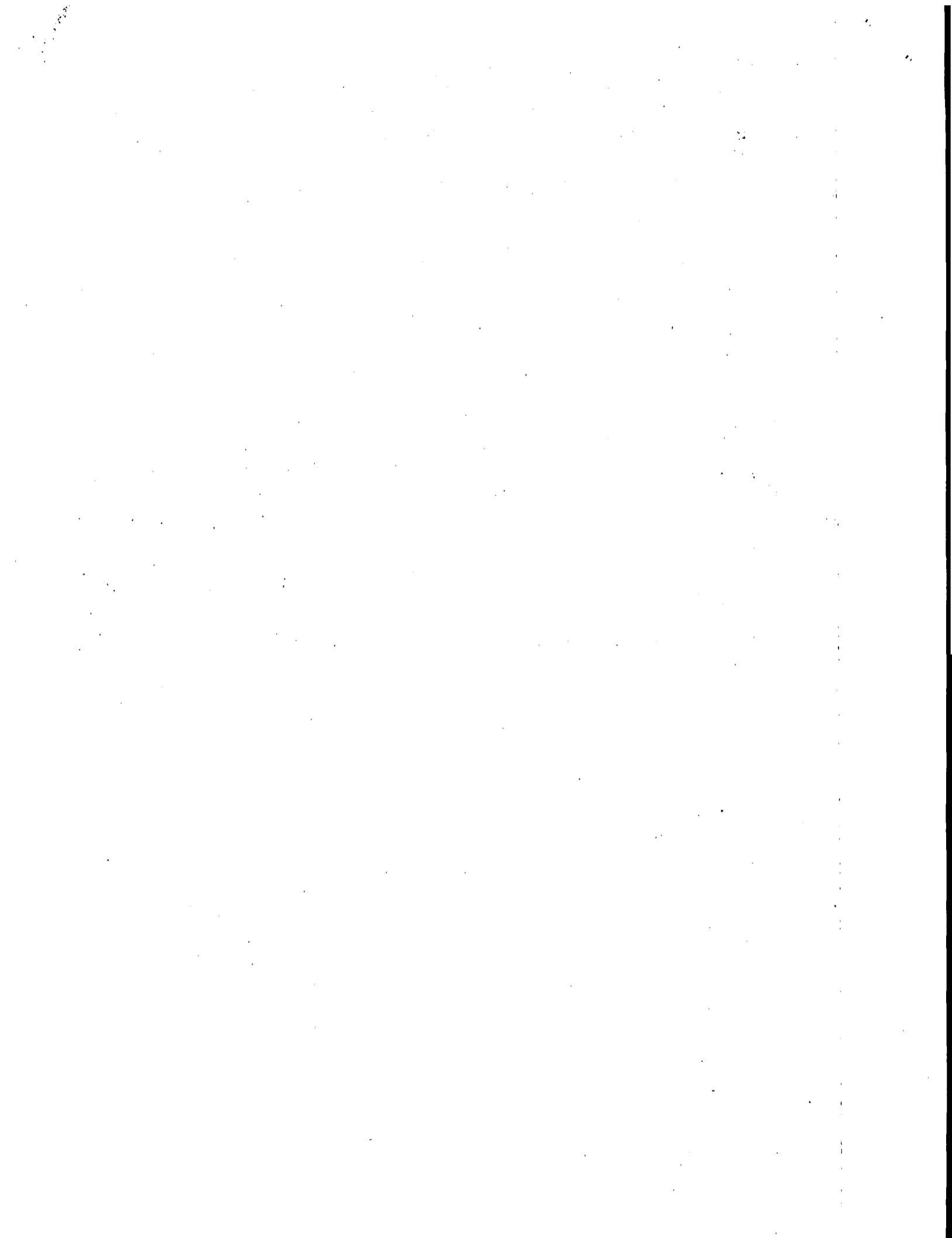

# Raytheon

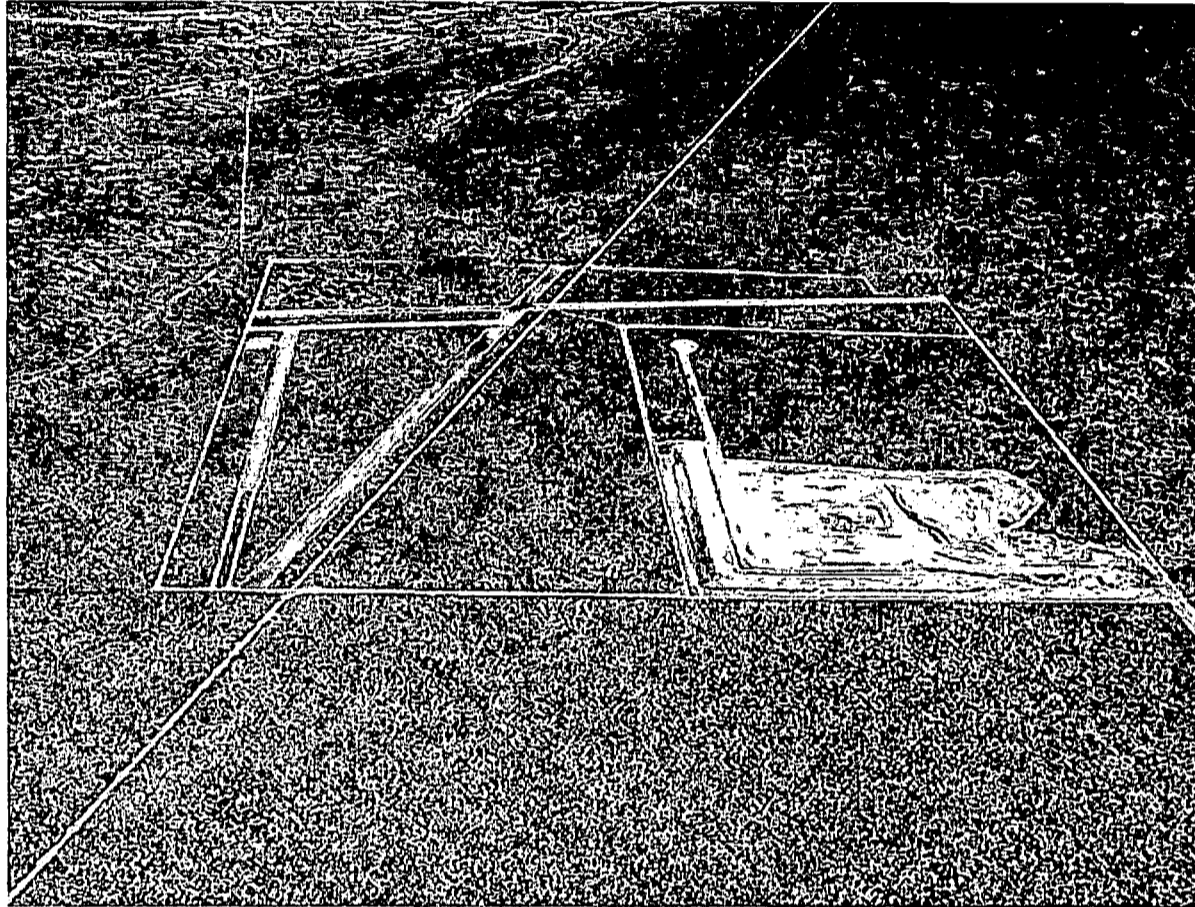

Figure: 2 UVI Airfield

UVI UAS airfield looking north, located next to the Cochise County landfill.

Phoenix Sectional

FHU 004/08.5, 4225' Elevation

N 31° 43' 30", W 110° 17' 47"

The UVI site is shown in Figure 2. This area shall be referred to as the Primary Containment Area (PCA). The 25 km arc defines the north east boundary between points 3A and 8A. This arc depicts the limits of the approved FCC frequency range. Raytheon is responsible for notifying the FAA of the breach of any operations area. Raytheon will operate below the 8000' MSL lower limit of R-2303B to remain outside of restricted airspace unless prior coordination has been obtained. The pattern altitude is 700' AGL. When not landing, Raytheon would operate at 2000' AGL and below, normally remaining between 1500' and 2000' AGL. Through UVI Inc, Raytheon has coordinated with the Libby Field Airspace Manager, El Paso Gas (pipeline patrol) and the Border Patrol, and has directly coordinated with Prescott Flight Service Station for NOTAMs. NOTAMs will be filed as directed by the FAA.

The Four Pillars (AZ21) airfield indicated in red on the map shown in Figure 3 is currently abandoned.

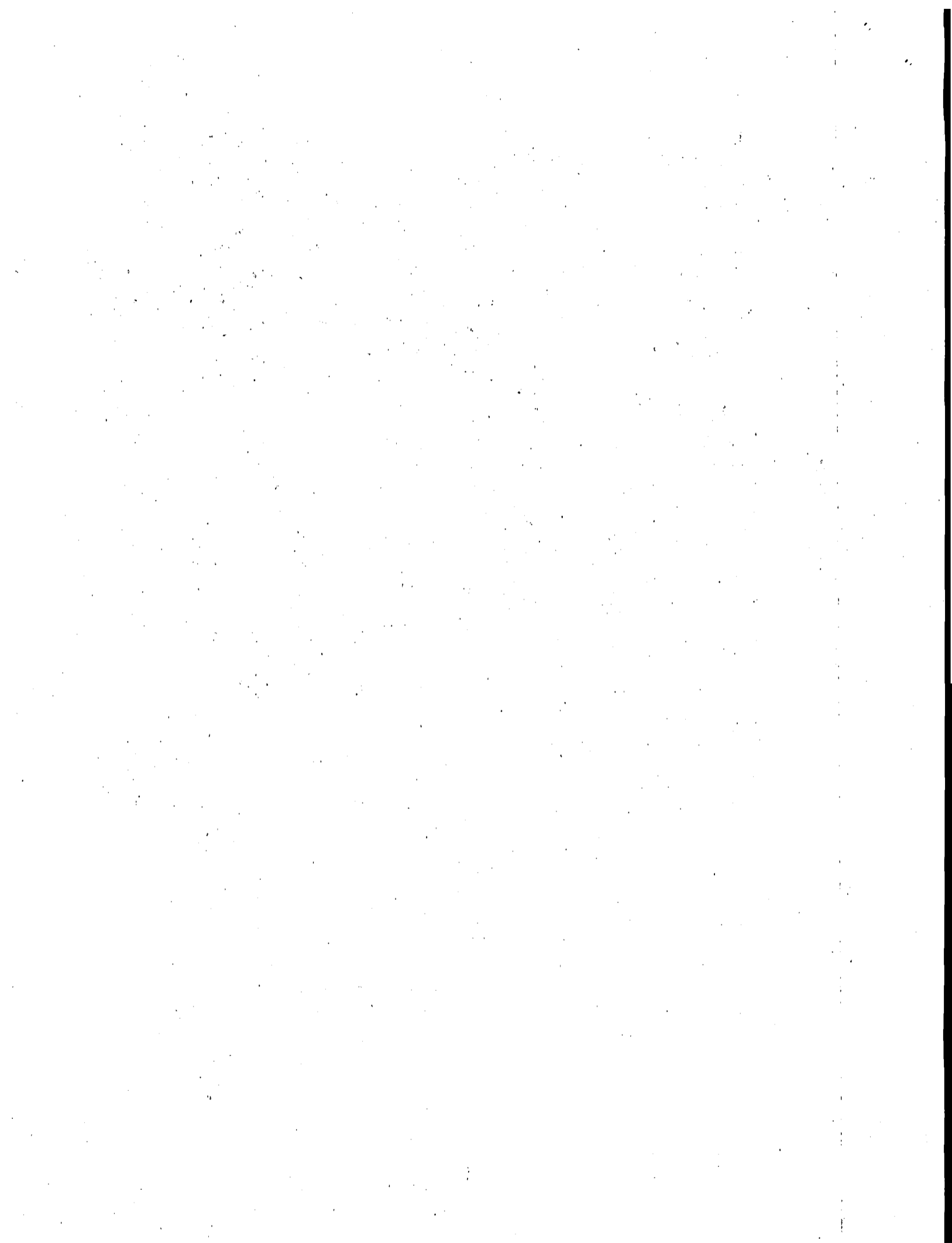

## **Raytheon**

The UVI site is located on state property and is operated on a state lease for the purpose of operating UAS. The State has approved the lease to UVI Inc for UAS operations only. From Highway 82 to the south to I-10 on the north, the land is nearly uninhabited. The only ground traffic in the proposed operating area is along Highway 80 from Tombstone to Benson.

The Raytheon local operating area is a 1 mile radius from UVI and the aircraft are kept north of Highway 82 and east of Highway 90. When flight operations will remain within 1 NM and the Ground Observer will be able to maintain visual contact, a chase plane will not be used.

In Figure 3, the larger area outlined with a hashed red line is the proposed Raytheon UAS containment area. This will be used for developmental testing and demonstration from the surface to 2000' AGL (6200' MSL average). All of Raytheon's UAS flight operations will be within radio line of sight of the Ground Control Station. Victor Airway 66 crosses the proposed operating area and has a Minimum Reception Altitude (MRA) of 9500' MSL (4500' AGL). VR 259 from points D to E, and VR 260 from points D to E, also cross this area, and Raytheon will contact Flight Service to see if they are active prior to crossing. For flights beyond visual range of the Ground Observer, a chase plane will be used. The chase plane and UAS will have active transponders when within the lateral limits of the VR routes.

The class E airspace overlaying the proposed operating area is used for instrument approaches into Libby Army Airfield (KFHU). The TOMBS intersection is the missed approach holding point at 9500' MSL, and the minimum vectoring altitude is 6500' MSL for IFR traffic. Raytheon reports operations to Libby Approach and monitors the approach control frequency during flight. By agreement with Libby Radar, Raytheon squawks 1200 mode C.

Ninety Percent of the proposed operating area is uninhabited state land. The cutouts at the corners of the proposed op area are designed to keep Raytheon UAS away from the small communities of Whetstone to the SW, St David to the north, and Tombstone to the SE. The eastern border is the edge of the Tombstone MOA. State highway 90 borders the western edge, state highway 82 the southern edge. The only trafficable road inside the op area is state highway 80, a two lane blacktop between Benson and Tombstone. The San Pedro river valley traverses the area south to north, and is a designated wildlife area. All flight operations over the wildlife area will be 2000' AGL.

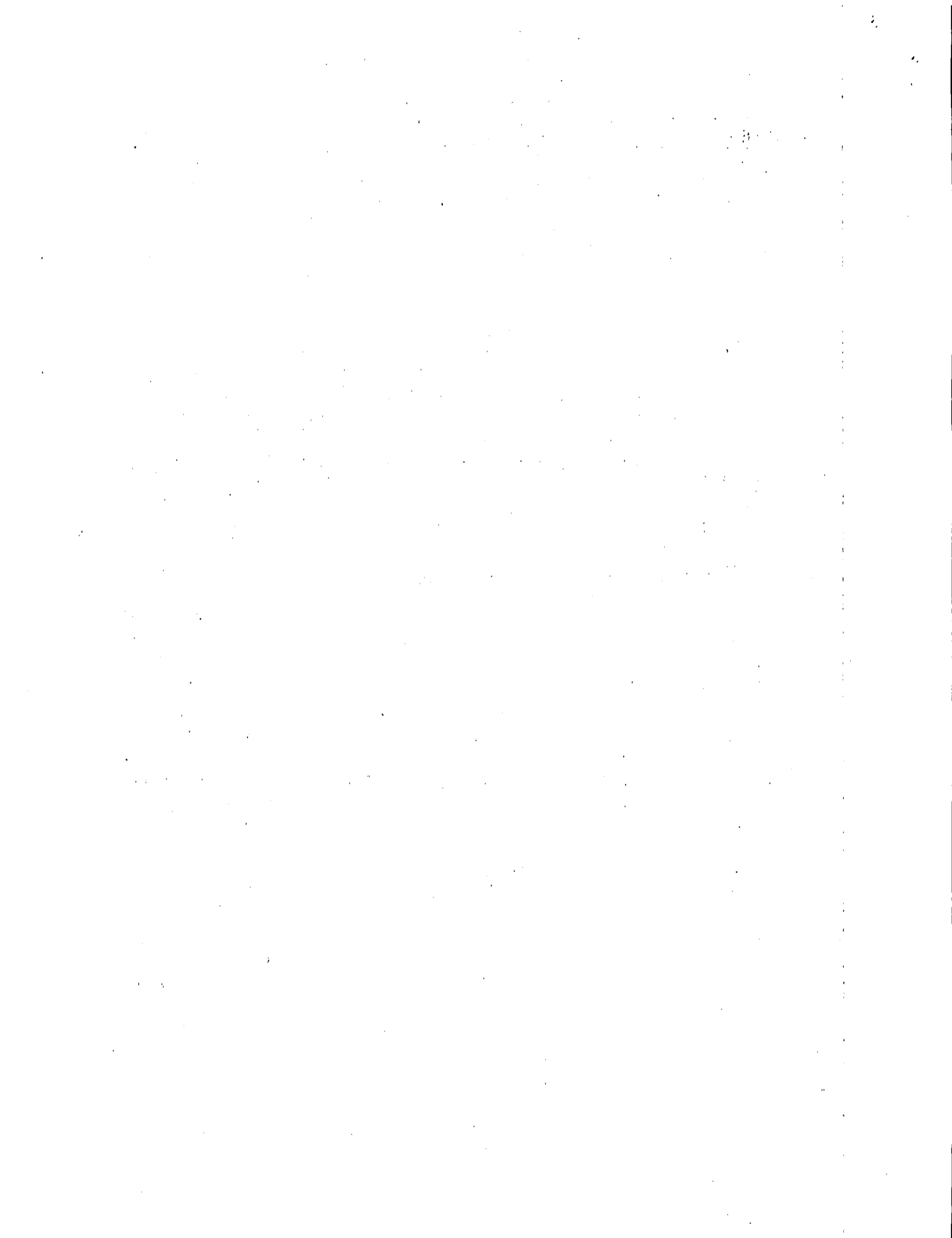

# Raytheon

- Identify all proposed flight areas using latitude and longitude on aeronautical maps.

The following grid coordinates define the Raytheon Op Area:

- (1) N 31° 44' 00.00" W 110° 20' 30.00"
- (2) N 31° 52' 00.00" W 110° 20' 00.00"
- (3) N 31° 52' 00.00" W 110° 11' 00.00"
- (3A) N 31° 56' 00.00" W 110° 11' 00.00"
- 25 km ARC from Whetstone -
- (8A) N 31° 45' 00.00" W 110° 02' 00.00"
- (9) N 31° 45' 00.00" W 110° 11' 00.00"
- (10) N 31° 43' 14.00" W 110° 14' 00.00"
- (11) N 31° 42' 00.00" W 110° 19' 30.00"
- (12) N 31° 44' 00.00" W 110° 19' 30.00"
- (13) Return to 1

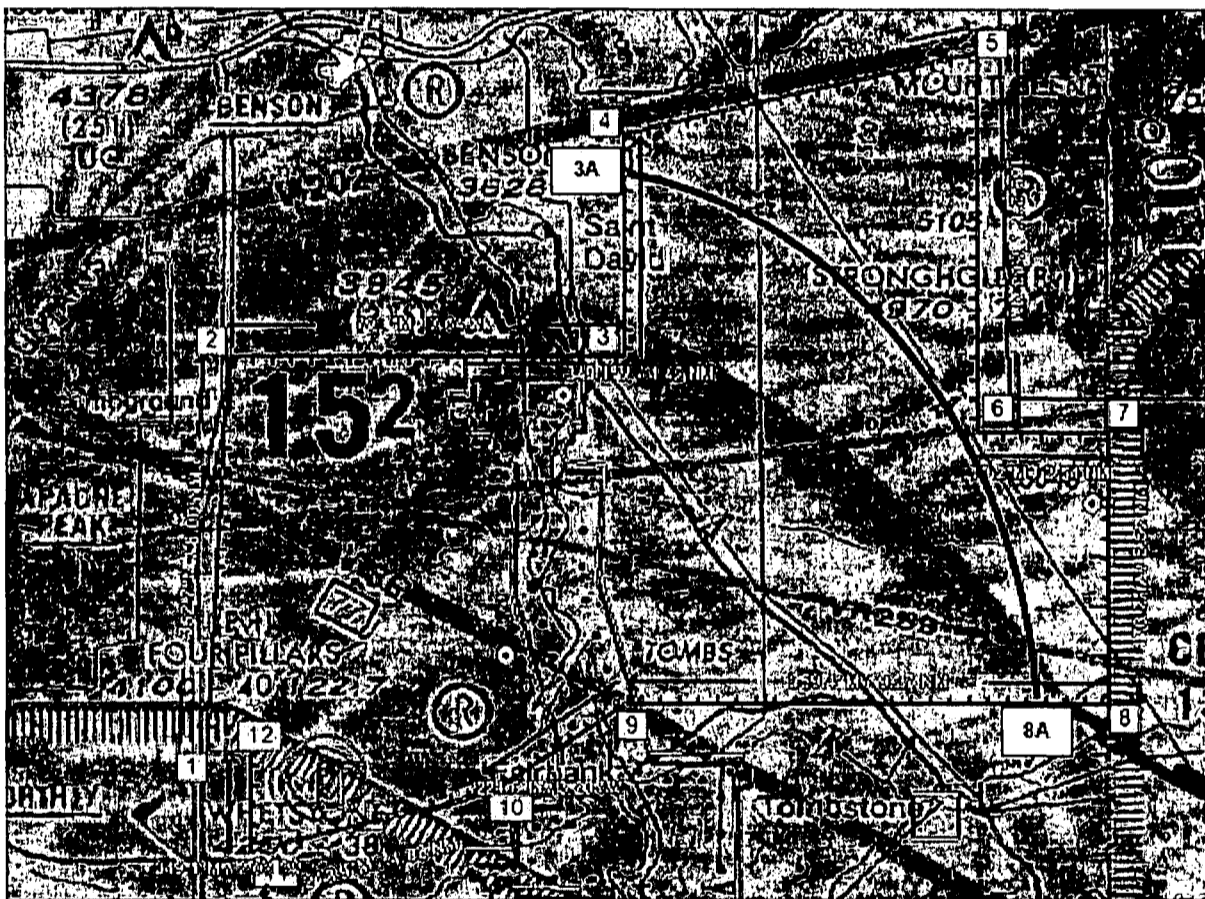
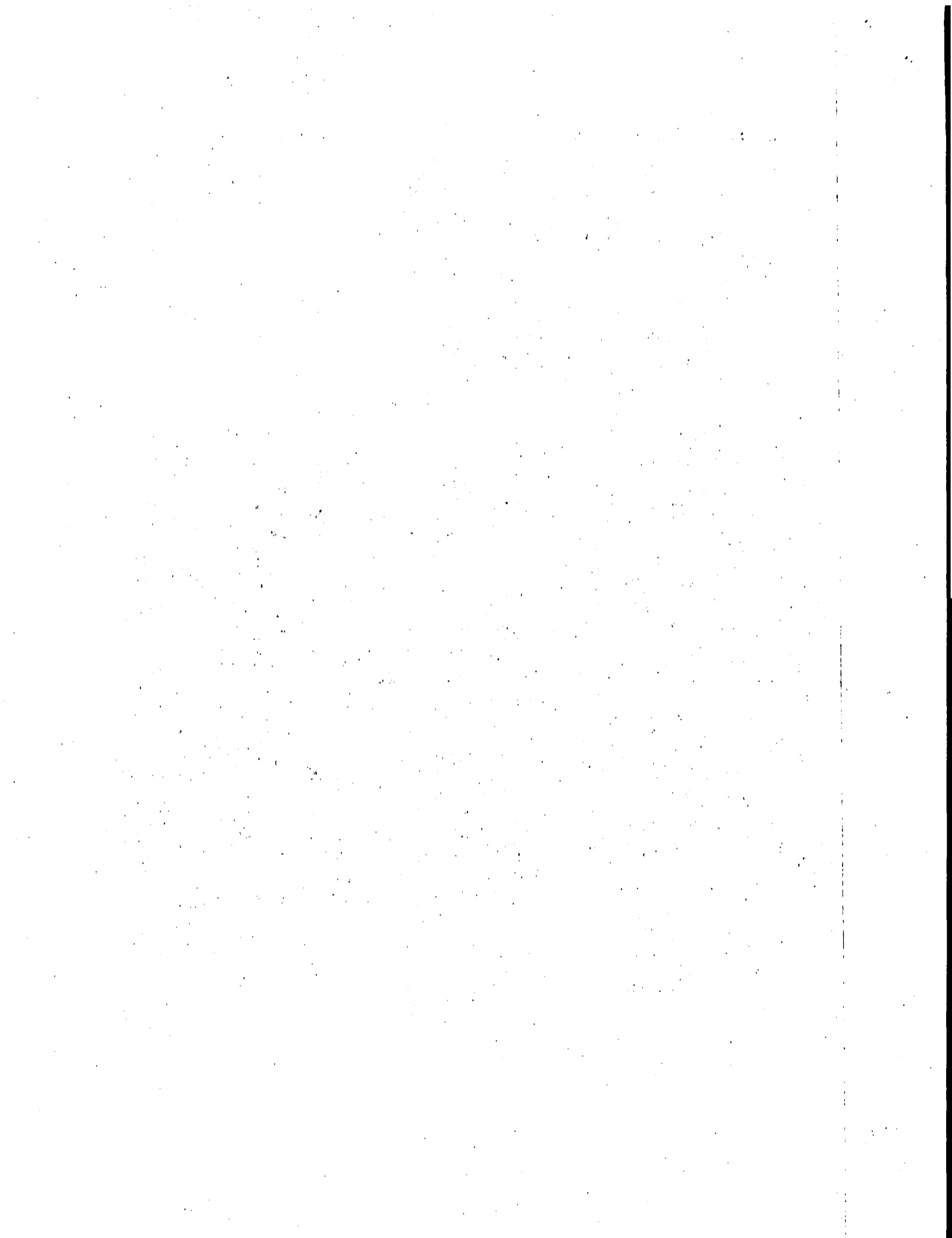

Figure 3. Phoenix Sectional, FHU 004/08.5, 4225' Elevation, N 31° 43' 30", W 110° 17' 47"





## Raytheon

Include information on airspeed, altitude, number of flight hours, number of flights and program duration for each test flight area.

Airspeed: 35-100 KIAS

Altitude: 2000 AGL and below

Winds: 20 KTS headwind, 10 KTS crosswind

Flight Hours: 300 flight hours per year

2-3 flight days per week during the workweek. Weekend flying will occur only once per quarter.

Duration: 1 year for this application, with renewal annually.

- What class of airspace will be used?

FAA Class E and G.

- Will minimum fuel requirements of 14 CFR § 91.151 be met?

Yes, a fuel reserve minimum of 30 minutes for day flying will be maintained.

- Will flight-testing include payload testing?

Yes. Various Electro Optic, passive and RF sensors will be tested. Frequency management will be coordinated with the FAA, FCC Western Region and Fort Huachuca frequency managers.

- What considerations need to be taken with regard to Payloads?

Considerations include size, weight, power requirements, EMI/RFI, drag, data communications and additional crew.

Size and weight of the payload will affect the aircraft weight and balance and maximum gross weight. The power draw on the onboard electrical system and backup batteries must also be considered. EMI/RFI might affect the aircraft as well as the payload. If the payload is external or has external components such as antennae, the drag increase must be evaluated. If the payload requires additional data communications, the effect on the available bandwidth and data priority as compared to command and control data will be evaluated. The addition of a payload will affect the workload of the crew depending on its complexity. The workload will be evaluated and an additional crew member added if required to operate the sensor. The addition of flight crewmembers or additional training will be considered when required for new payload operations.

- Will the aircraft perform any aerobatic maneuvers?

No

- Flight Conditions (e.g., VFR, IFR, VMC, etc.)

Day VFR only. All testing, training and demonstration will be conducted in Day VFR conditions.

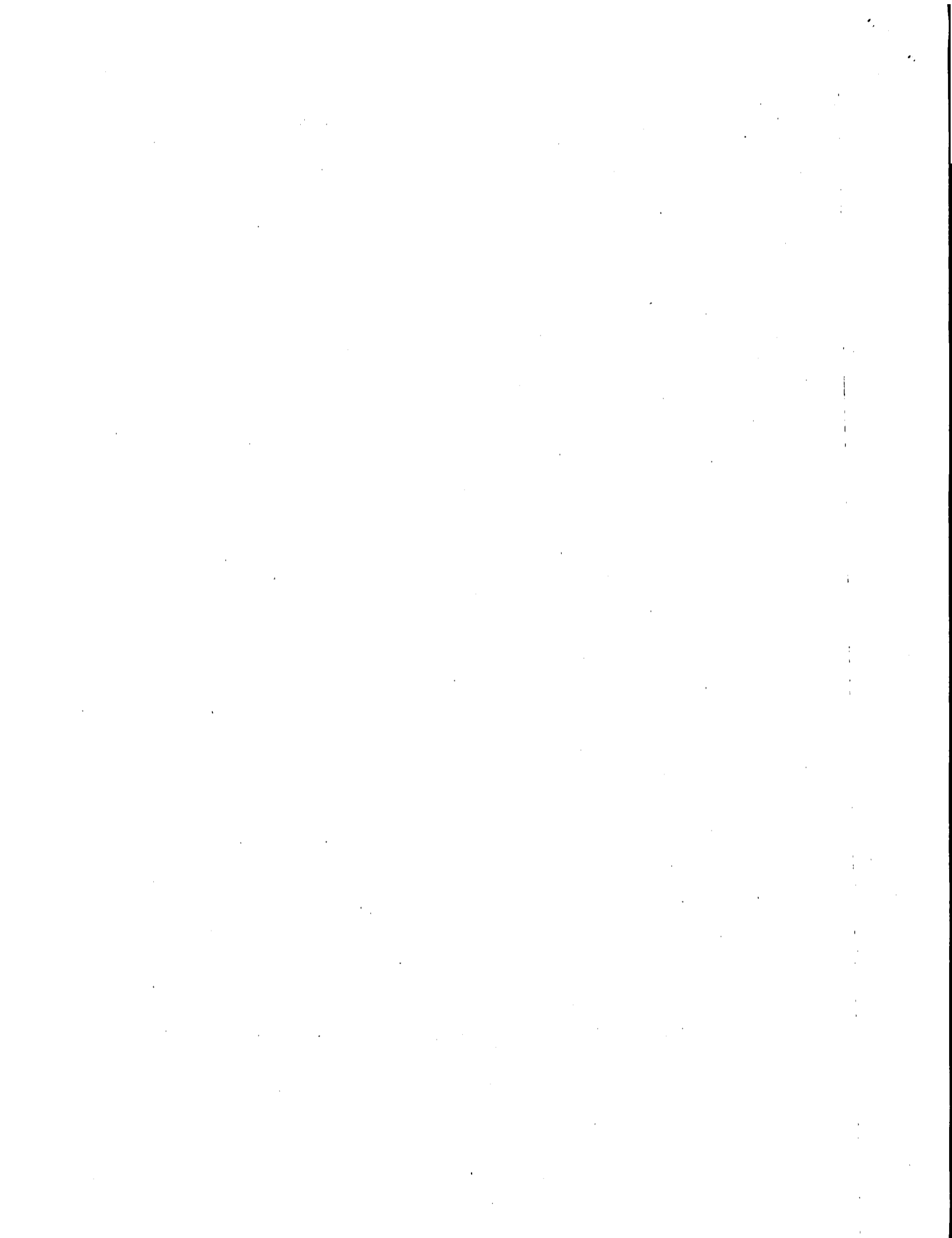

## 4. Aircraft Configuration

- Attach three-view drawings or three-view dimensioned photographs of the aircraft (14 CFR § 21.193(b) (4)). (Appendix A)

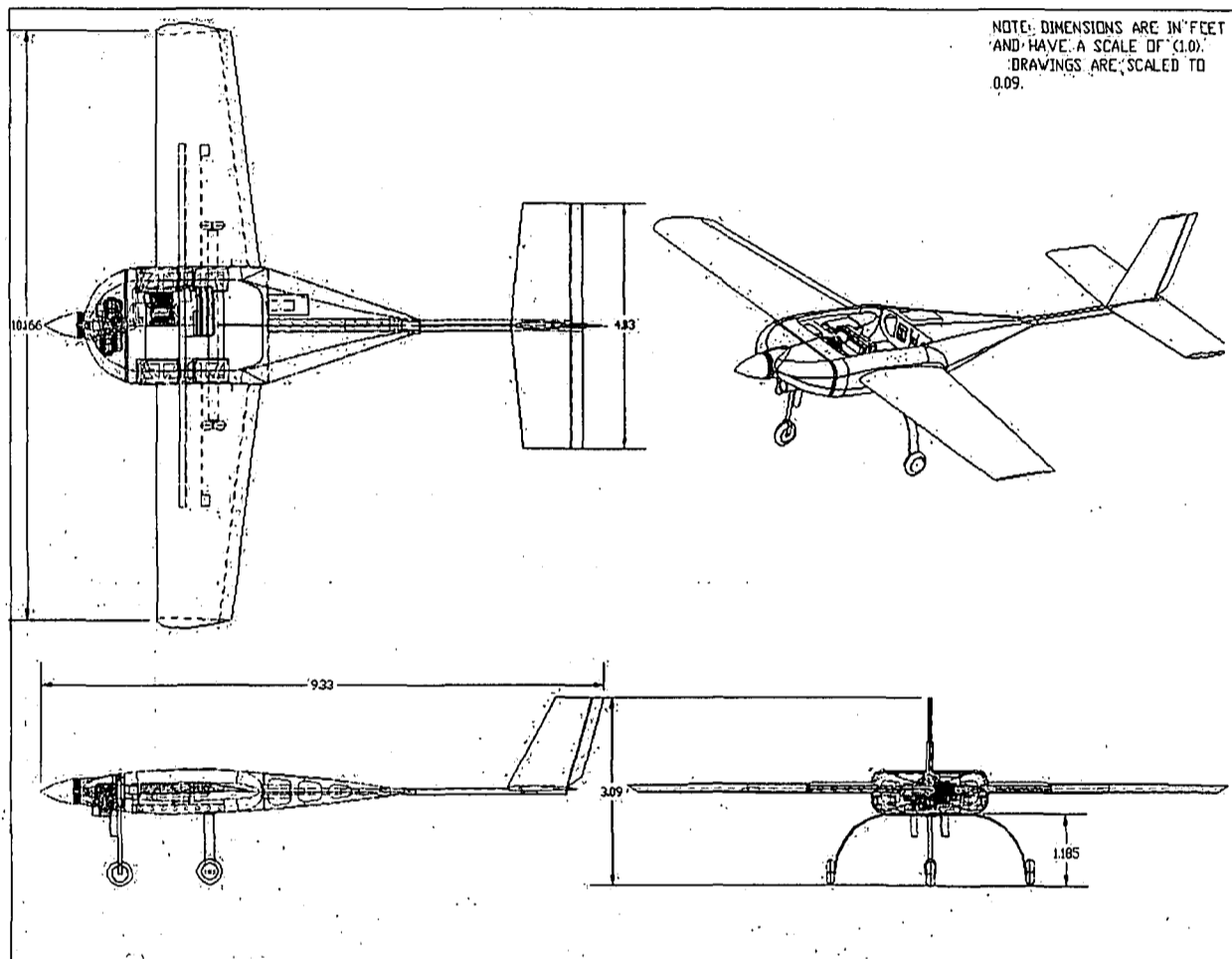

Figure: 4 Cobra 3 View Drawing

- Describe Unmanned Aircraft System configuration including ground control station.

- Cobra UAS

- Cloud Cap Piccolo II Autopilot (<http://www.cloudcaptech.com/>)

See Appendix B – Piccolo Systems Users Guide

The Piccolo II is a MEMS based autopilot that allows for manual, stability augmentation, and autonomous control of the UAS. The air data system, GPS, and Microhard datalink are built into a compact, low weight, avionics package. A Honeywell magnetometer provides magnetic heading information to the autopilot.

- DGPS (<http://www.novatel.com/products/flexpak.htm>)

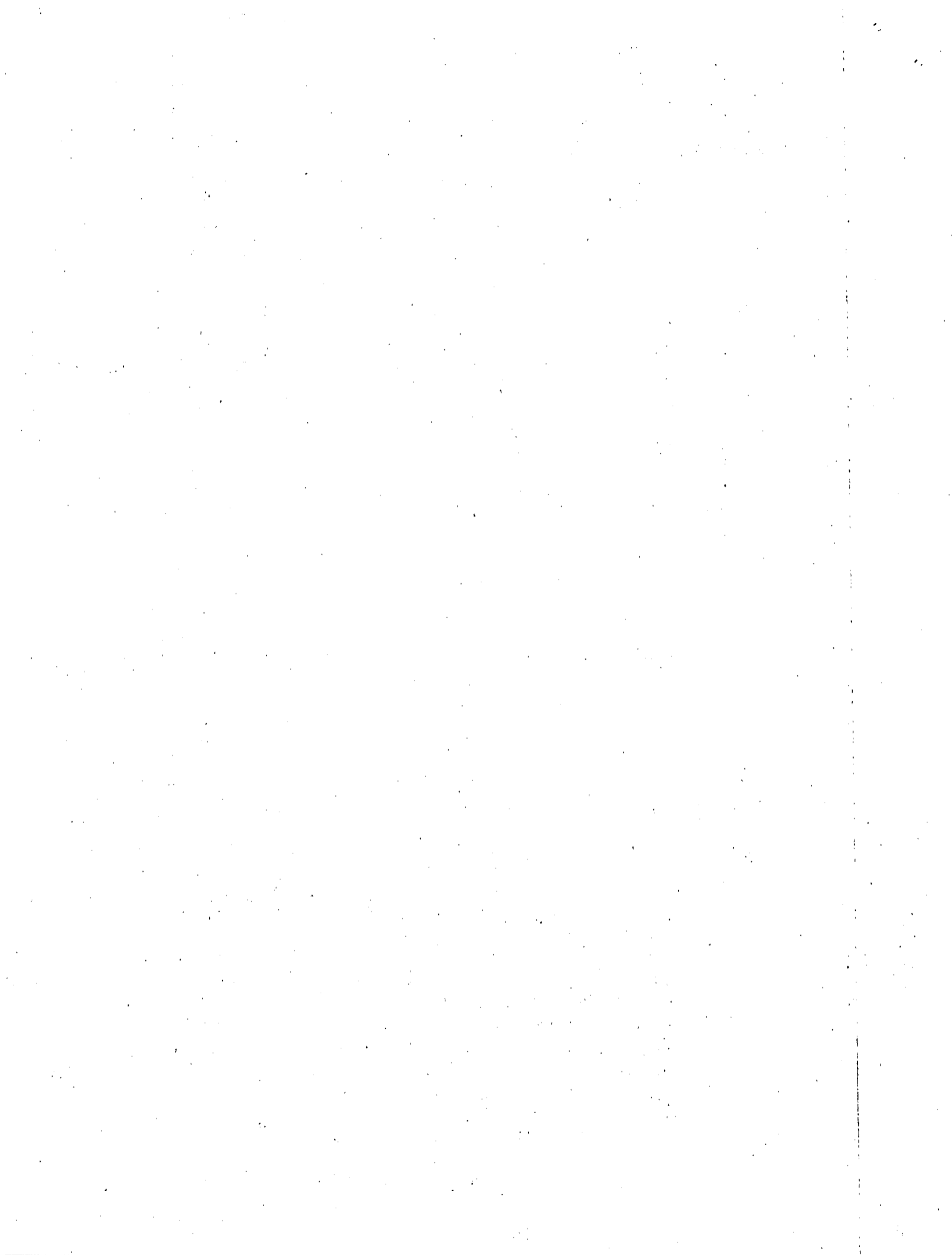

## Raytheon

A Novatel FlexPak-G2L DGPS provides centimeter level accuracy for Autonomous takeoff and landing operations.

- Transponder

Microair 2000, mode 3a/c with air data provided by an altitude encoder or the Piccolo II flight control system.

The transponder will be required for all flights.

- Lights

A white strobe light will be attached to the upper fuselage as an anti-collision light for all flights.

- Video Transmitter

An independent COTS ¼ to 3 watt video transmitter at 2.4 GHz will be used for transmission of the video signal.

- Power

Primary electrical power comes from a 500 watt generator with a 180 watt regulator. A Lithium Polymer rechargeable battery provides backup electrical power for 1 hour in the case of main power source failure. The battery is charged in flight.

The system voltage is indicated to the pilot as well as a visual and audio alert if the high or low voltage range is exceeded. While on Generator power (14.8 volts) the voltage is green. If the generator fails, the battery (15.8 volts) comes online and the alert sounds. Once the battery is below 14.8 volts the alert will stop until the low voltage value is exceeded.

- Datalink

- Microhard MHX UHF Datalink

The Piccolo autopilot has an integrated MHX-910 frequency hopping radio from Microhard Systems Inc. The MHX radio is a 900MHz ISM band radio with good receive sensitivity and a maximum 1 Watt output power. The wireless link formed between radios extends from all the aircraft to the ground station. Traditional wireless links were made of a single frequency, and multiple networks could be constructed by using multiple frequencies. With a frequency hopping radio the concept of networks defined by frequencies is replaced with networks defined by hopping patterns. Hence it is possible to have a network of radios using one hopping pattern while another network of nearby radios uses a separate hopping pattern. In each case a single ground station coordinates the communications for each network.

The Microhard radio has a 25 NM range and is used as the Primary control link when installed alone or as the secondary link and flight termination system if a developmental datalink is installed.

1. The first part of the document discusses the importance of maintaining accurate records of all transactions and activities. It emphasizes that proper record-keeping is essential for ensuring transparency and accountability in financial reporting.

2. The second part of the document outlines the various methods and techniques used to collect and analyze data. It highlights the need for consistent and reliable data sources to support the findings of the study.

3. The third part of the document presents the results of the analysis, showing a clear trend of increasing activity over the period studied. This trend is supported by the data collected and analyzed.

4. The fourth part of the document discusses the implications of the findings and provides recommendations for future research and practice. It suggests that further investigation is needed to understand the underlying causes of the observed trends.

5. The fifth part of the document concludes the study and summarizes the key findings. It reiterates the importance of accurate record-keeping and the need for ongoing monitoring and evaluation of the data.

## Raytheon

- Raytheon MicroLight UHF Datalink

The MicroLight radio is based on the Raytheon Enhanced Position Location Reporting System (EPLRS) technology. This is a software programmable digital datalink operating from 420-450 MHz. This radio is networkable, allowing the radio to act as a node in a network. This radio has a 100 NM range. The range is variable with the selected mode of operation.

The MicroLight UHF Datalink is developmental and can be used for C2 and low rate video. This radio will be evaluated for Joint Tactical Radio System (JTRS) waveforms, and its usability within a net-centric UAS.

- Other developmental datalinks (See Proprietary Payload Addendum)

For all datalink testing, the original MicroHard link provided with the Piccolo II autopilot will be maintained as a secondary safety backup and flight termination system.

- Ground Control Station

- Raytheon Multi-Vehicle Control System (MVCS)

The MVCS is a derivative of the US Navy Tactical Control System and can be used to control different types of UAS as long as a STANAG compliant Vehicle Specific Module (VSM) has been created for that aircraft. STANAG 4586 is a NATO standard for interoperability between diverse UAS. The MVCS is networkable allowing multiple pilot consoles to be connected together and to share data. MVCS is also designed to be hosted on the Digital Common Ground Station (DCGS) developed by the US Air Force.

- STANAG 4586 Vehicle Specific Module (VSM)

The VSM is the interface or translator between the aircraft and the ground control station. It is software, and can be hosted on an airborne processor in the aircraft or the computer connected to the Ground Control Station. The VSM used by the Cobra is the same as that used on the Manta and Silver Fox UAS. The VSM interface for these aircraft was created to communicate with the Piccolo autopilot.

- STANAG 4586 Common UAV Control Station (CUCS)

The CUCS is the operator interface to the system controls. It provides the displays of information to the Pilot (Figure 7). The displays are configurable and can be considered a virtual Multi-Function Display (MFD). The displays include the Primary Flight Display (PFD), a moving map or situational awareness display, Warnings and Cautions, and various data displays for the aircraft telemetry. This system allows satellite imagery to be used as a moving map display. When more than one UAS telemetry stream

1. The first part of the document discusses the importance of maintaining accurate records of all transactions and activities. It emphasizes that proper record-keeping is essential for transparency and accountability, particularly in financial reporting and auditing. The text notes that incomplete or inaccurate records can lead to significant errors and potential legal consequences.

2. The second part of the document outlines the various methods and tools used to collect and analyze data. It mentions the use of spreadsheets, databases, and specialized software to ensure that data is organized and accessible. The importance of data integrity and security is also highlighted, as well as the need for regular backups and updates to the systems used.

3. The third part of the document focuses on the process of data analysis and interpretation. It describes how raw data is processed into meaningful information through various statistical and analytical techniques. The text stresses the importance of using appropriate methods and tools to ensure that the results are accurate and reliable. It also discusses the role of data visualization in presenting complex information in a clear and understandable way.

4. The fourth part of the document discusses the challenges and limitations of data analysis. It notes that data can be incomplete, inconsistent, or biased, which can affect the results of the analysis. The text also mentions the potential for human error and the need for careful oversight and validation of the results. Finally, it discusses the importance of staying up-to-date with the latest developments in data analysis and technology.



is detected on the network, all UAS positions are shown on the map with an ID and altitude tag.

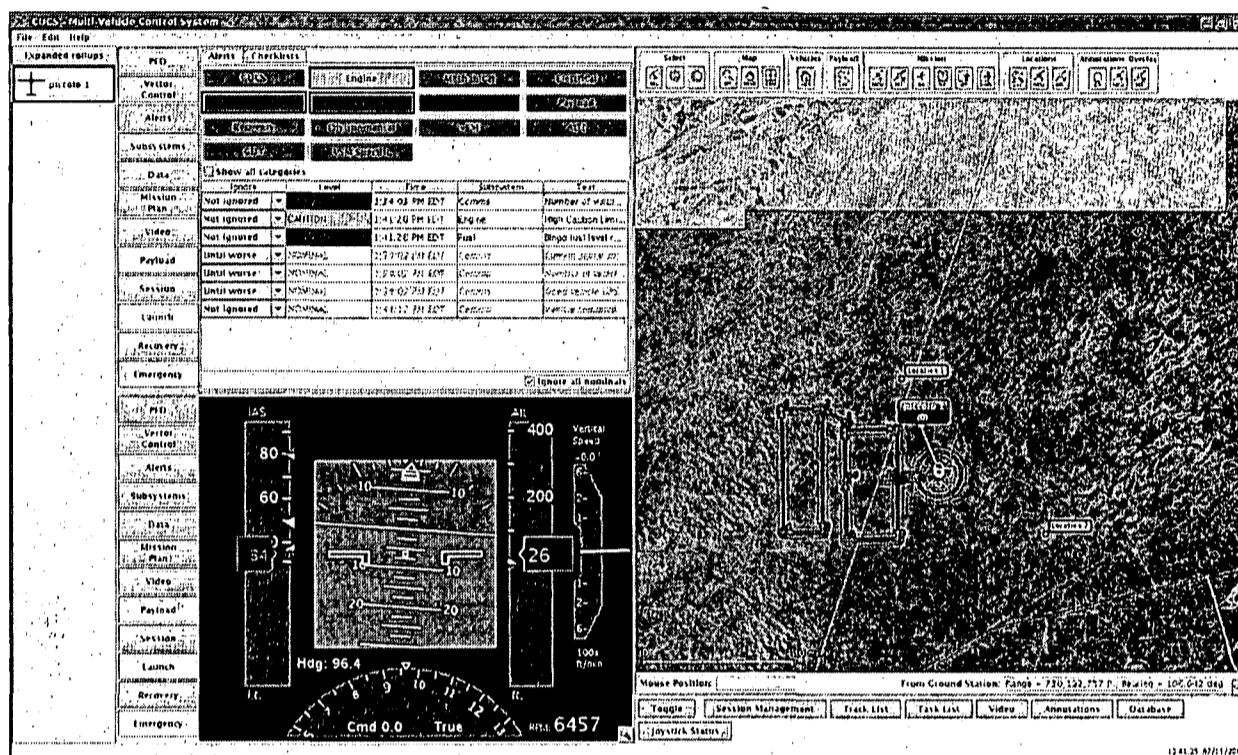
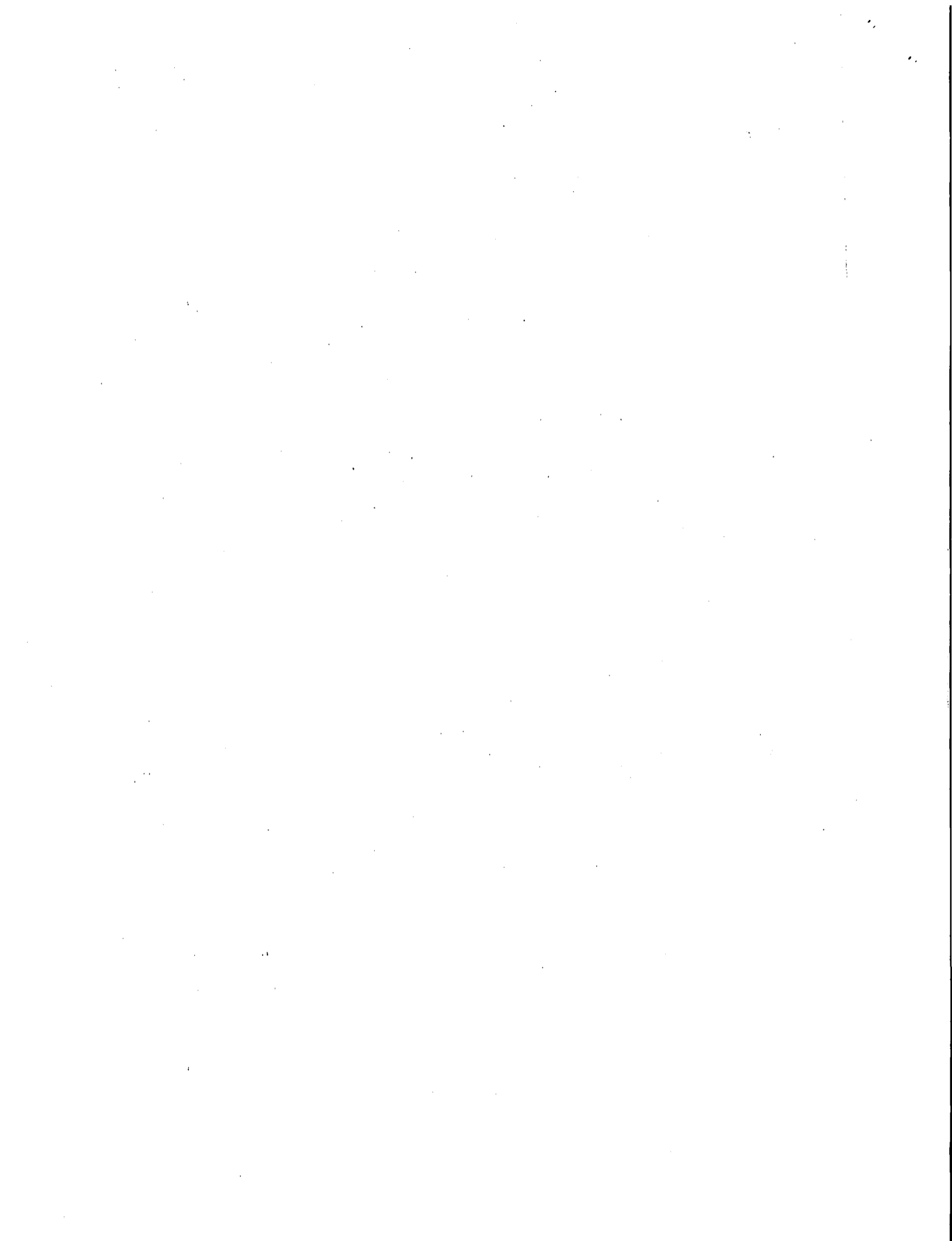

Figure: 5 MVCS CUCS

- Cloud Cap Piccolo Operator Interface
  - See Appendix B – Piccolo Systems Users Guide. The Piccolo Operators Interface can be used as a stand alone or in concert with the MVCS. Often it is used for preflight and launch/recovery while the MVCS is used for cruise flight. This allows multiple pilots to manage multiple aircraft from a series of networked pilot consoles.
- Payloads
  - See Proprietary Addendum
- Include a description of aircraft/system performance characteristics:
  - Wing span: 10.166 FT.
  - Length: 9.33 FT.
  - Power Plant: Desert Aircraft, DA-150, 16 HP, Air Cooled, Two-Cylinder Opposed, 2 Stroke Gasoline Engine
  - Max Gross Take Off Weight: 115 LBS
  - Fuel capacity: 4.0 GAL, 87-100 Octane with 100:1 oil mix
  - Payload Capacity: 30.0 LBS



# Raytheon

- Max altitude: 15,000 FT. MSL
- Endurance: 4 hours
- Max airspeed: 95 KTS
- Wind Limitations: 20 KTS headwind 10 KTS crosswind
- Control/data frequencies: 420-450 MHz Primary, 902-928 MHz Secondary
- Guidance and navigation control: Cloud Cap Technologies Piccolo II Autopilot
- Flight termination frequencies, if any: 902-928 MHz. Raytheon uses the Microhard datalink as a flight termination device when developmental datalink is installed.

## 5. Inspection And Maintenance (14 CFR 91.7)

- Describe the inspection and maintenance program that will be used to maintain the aircraft and related systems (includes ground stations and/or other support systems).

See Raytheon Cobra UAS Inspection Plan

An aircraft logbook will be maintained on each aircraft, and a separate logbook for the ground control station. An engine log will be maintained for each engine as well.

The engines will be overhauled at 250 hours.

Discrepancies and maintenance actions will be noted in an electronic format used by Raytheon Integration and Test, and repairs will be made by Flight Test Team engineers. Preflight and postflight inspections will be conducted for all flights, as well as periodic inspections during integration and development.

An annual inspection will be conducted in accordance with the Cobra Inspection Plan.

Raytheon maintains a Test Readiness Review (TRR) process, where any changes to the configuration of the system must be approved by a board of senior engineers prior to testing. The status of all aircraft and any outstanding maintenance actions are reviewed at this time. Flight safety is the primary concern of the TRR.

- Provide copy of flight manual, if applicable, current weight and balance report, equipment list.

The Raytheon Cobra UAS Operations and Weight and Balance are included as appendix C and D.

The small size of the aircraft allows it to be weighed, and Center of Gravity (CG) calculations done prior to each flight. The data is collected and has been used to create a basic weight and balance calculator in a spreadsheet. The weight and cg envelope shows the limits of data collected to date. CG expansion tests will be conducted during aircraft performance testing.

A minimum equipment list is shown in Appendix E.



## 6. Pilot Qualification (14 CFR §§ 61.3, 61.5)

- Describe the qualifications for each pilot.

See the Raytheon Cobra UAS Training Plan.

The Cobra requires a crew of 1 pilot. If required a Supplemental Pilot (SP) can assist the Pilot. The UAS pilot will be an FAA certified pilot for all flights, and shall be designated the Pilot in Command (PIC).

Pilot –FAA certified Private Pilot Airplane, physically and medically capable of completing all required tasks, and complete a UAS Practical Flight Test administered by the Raytheon Chief UAS Pilot or his designee. The Pilot must hold an FAA 3d class medical certificate.

Supplemental (External) Pilot (SP) – 3 Years previous RC Model experience with a similar aircraft or FAA certified Private Pilot Airplane, physically and medically capable of completing all required tasks, and complete a UAS Practical Flight Test administered by the Raytheon Chief UAS Pilot or his designee. The Supplemental Pilot must hold an FAA 3d class medical certificate and complete the FAA Private Pilot written test.

Observer - physically and medically capable of completing all required tasks, and approved by the Raytheon Chief UAS Pilot or his designee. The Observer must hold an FAA 3d class medical certificate and complete the FAA Private Pilot Written test.

The Pilot flies using the pilot computer console by reference to the Multi-Function Display, and other telemetry data, using the autopilot functions or the manual pilot console. The Pilot will take direction from Air Traffic Control or Observer to avoid other aircraft.

The PIC is responsible for the conduct of the flight, coordination, weather and preflight planning.

The Supplemental Pilot flies by visual reference using the manual pilot console. When in control, the SP will maneuver as required to avoid other aircraft. The SP cannot act as Observer when in control of the aircraft.

An observer will be assigned for all flights. He can be on the ground or in the chase aircraft.

An example of the Raytheon pilot qualifications are listed below:

### Chief UAS Pilot

Certified Flight Instructor-Airplane, Commercial Instrument ASEL, AMEL, Commercial Glider, Commercial Helicopter, Airframe and Powerplant Mechanic, Chase Plane Pilot UAS Pilot, UAS Test Pilot, UAS Instructor, Sensor Operator, Observer, 1200+ UAS hours, Gnat 750, IGnat, Pioneer, Sentry STM-5A/B, Exdrone, Pointer, Manta, Silver Fox, Cobra

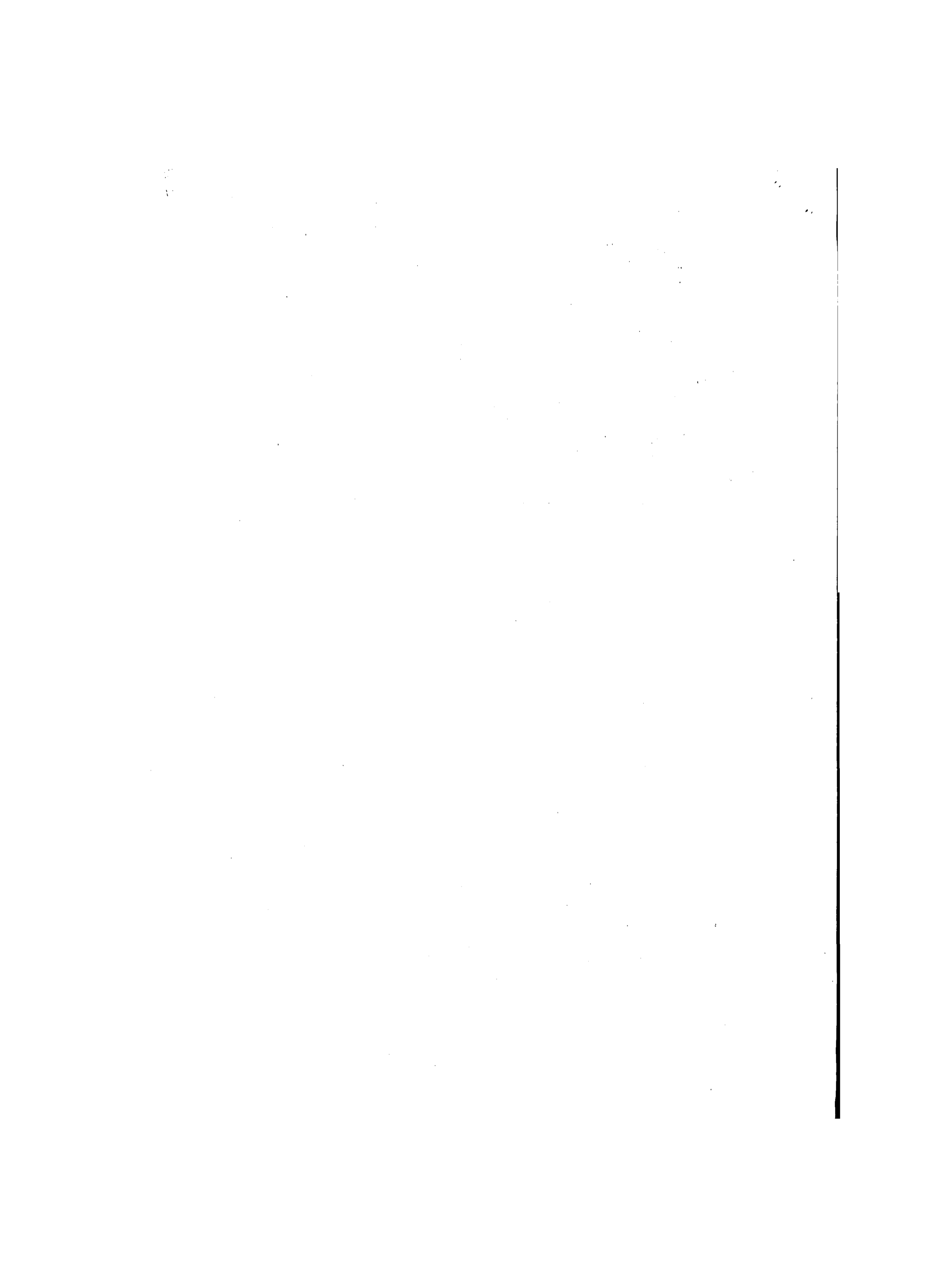

# Raytheon

## Supplemental Pilot

RC Pilot, RC Test Pilot, UAS Pilot, UAS Test Pilot, UAS Instructor, Observer, 230+ UAS hours, Manta, Silver Fox, Micro Fox, MAV, SUAV, LUAV, Cobra

- Pilots must be qualified and/or certificated in the appropriate category of aircraft, i.e., rotorcraft, powered lift, airplane, etc.
- Describe internal training program to qualify pilots.

Pilots are chosen for their experience with UAS, manned or RC aviation. Manned aircraft pilots are trained to be UAS Pilots, and RC pilots are trained to be Supplemental Pilots (SP).

All pilots are given detailed information on the UAS system, including aircraft performance, limitations, flight controls, communications, autopilot functions, datalink operation, local procedures, crew coordination and emergency procedures.

In addition, specific training will be given in the following areas as it pertains to UAS operations:

- Applicable Federal Aviation Regulations
- NTSB Accident reporting requirements
- Aeronautical Information Manual and FAA advisory circulars
- Aeronautical charts for navigation
- Radio communication procedures
- Weather, windshear avoidance, and aeronautical weather reports and forecasts
- Aircraft collision avoidance, and wake turbulence;
- Density altitude effects
- Weight and balance computations
- Principles of aerodynamics, powerplants, and aircraft systems
- Stall awareness, spin entry, spins, and spin recovery techniques
- Aeronautical decision making and judgment
- Preflight action that includes how to obtain information on runway lengths at airports of intended use, data on takeoff and landing distances, weather reports and forecasts, and fuel requirements.
- Preflight preparation, preflight procedures, airport operations, takeoffs, landings, and go-arounds, navigation, slow flight and stalls, emergency operations, and postflight procedures.

The Pilot is given additional training on the software operator interface, and mission commander duties and is required to be familiar with SP pilot duties. A simulator is used prior to Pilot flight training. Pilots will demonstrate this knowledge to the correlation level prior to Raytheon certification.

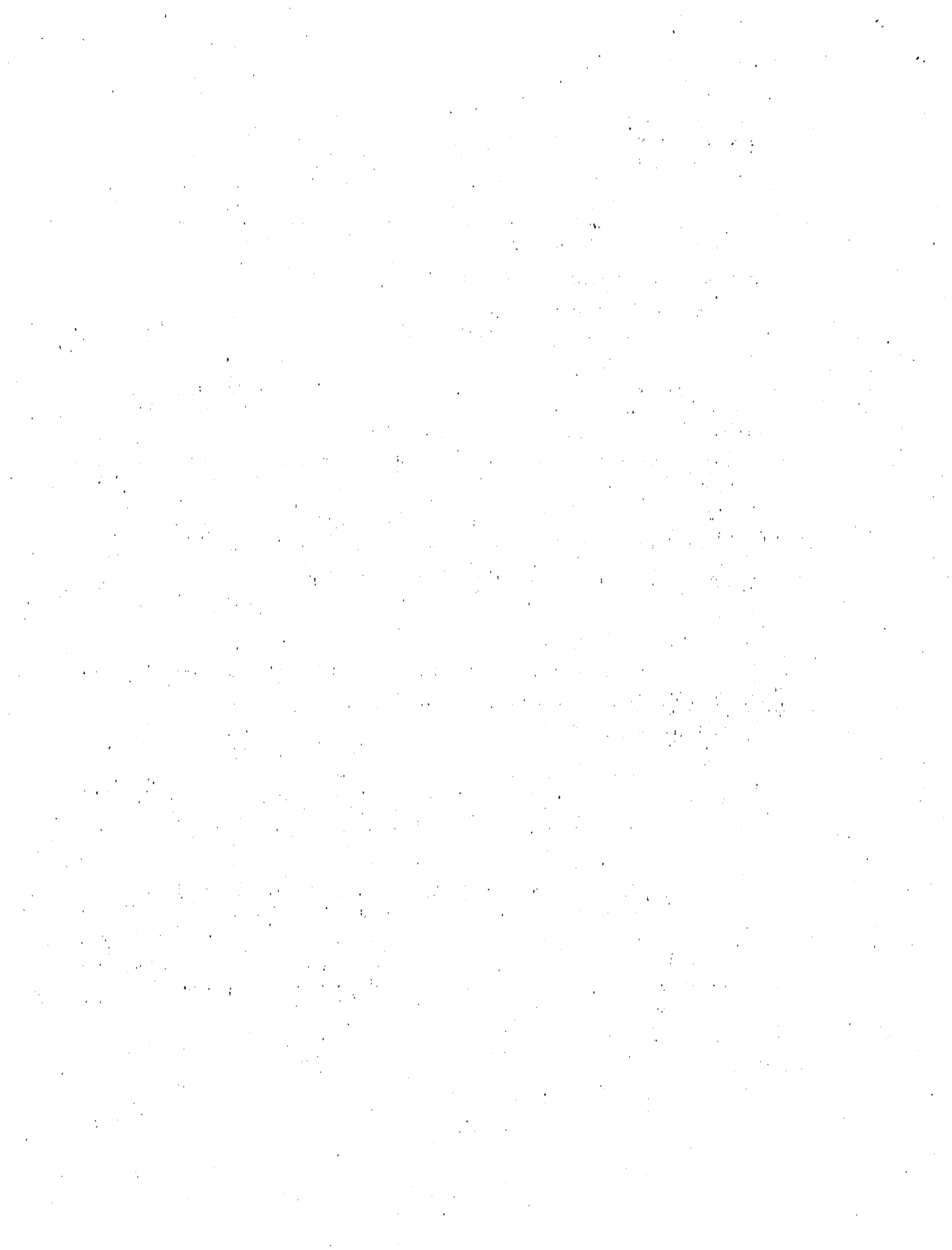



## Raytheon

The SP is also trained to take manual control as required to avoid other aircraft and is required to be familiar with pilot duties.

- Describe the qualifications and training of observers.

Observers are trained in scanning techniques, and to verbally communicate the location of other aircraft. Observers will have instruction on 14 CFR § 91.111 and 91.113.

### 7. Aircraft Marking (14 CFR § 45)

- All Cobra UAS are required to be registered and identified with the registration number. (45.29(f))
- Unless otherwise specified in the certificate, the aircraft will be marked on the aft fuselage surface using the N12345 format. 3" lettering will be used due to the small size of the aircraft. The word "Experimental" will be displayed on the fuselage over the wing in ½" letters.

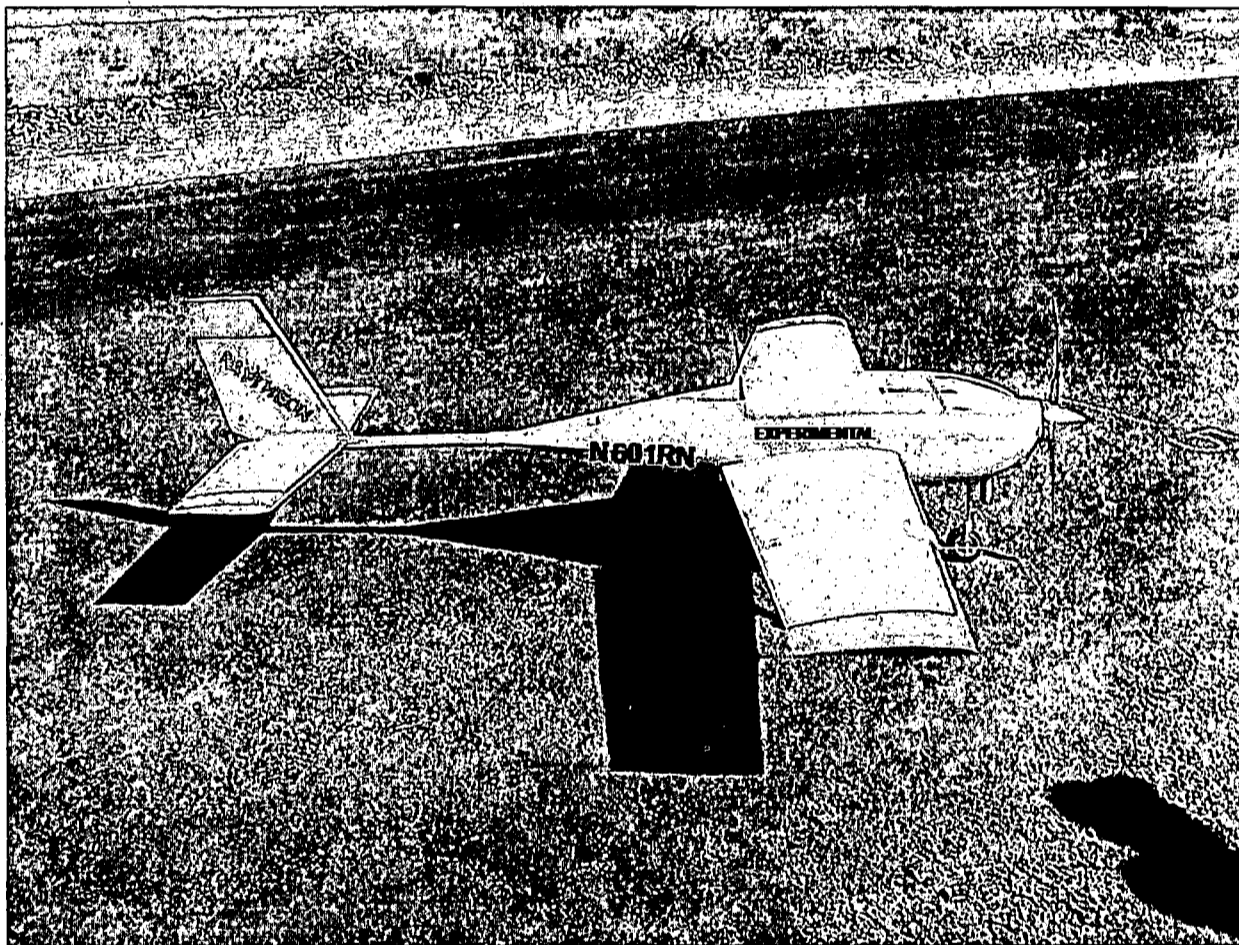

### 8. ATC Transponder and Altitude Reporting System Equipment and Use (14 CFR § 91.215)

- Describe the aircraft altitude reporting system.

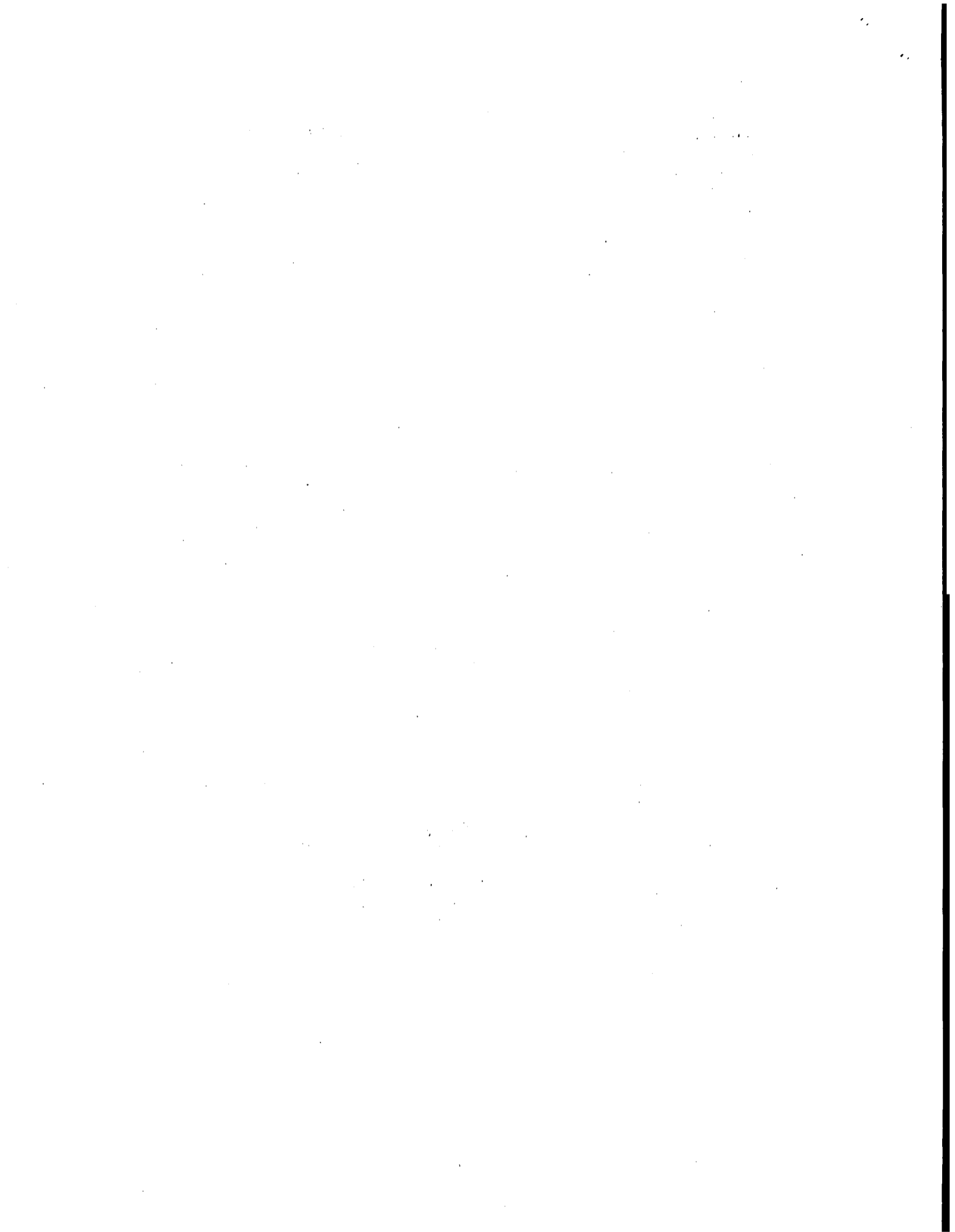

## **Raytheon**

The aircraft has a miniature air data system built into the autopilot. Altitude calibration is done daily via the GCS operator interface by setting the field elevation and local barometric pressure. The local barometric pressure is received from the ATIS broadcast from Libby Army Airfield.

An onboard Transponder with altitude encoder is installed. See Appendix E MEL. An independent Altitude Encoder will provide the pressure altitude for mode C. During integration testing, the mode 3 code will be manually set to 1200 or as assigned before launch. When the software interface has been developed, the transponder will be accessible to the pilot for mode 3 code changes, ident, and Off/Standby/On/Alt functions.

### **9. Method for See and Avoid (14 CFR § 91.113a)**

- In what manner, or by what means, will the requirement to “see and avoid” other aircraft be met?

For local flights a ground observer will be used to see other aircraft.

Raytheon will have a chase plane for all flights outside visual line of sight. The chase plane will be manned by a pilot and observer. Raytheon will comply with the FAA definition of observer. The roll of the observer will be to look for and call out all other air traffic. The observer will not have FTS capability. Voice communications between the chase aircraft and the UAS pilot at the Ground Control Station will be by VHF radio. In the event voice communication is broken with the chase aircraft for more than 1 minute, the UAS will be returned for landing. At any time during the flight, the UAS pilot will be able to take control and maneuver as required to avoid other aircraft as directed by the chase plane observer. In an emergency the UAS pilot can execute the terminate flight function built into the autopilot. The chase aircraft will be squawking 1200 or as assigned. The pilots of the chase aircraft and UAS will have a face to face formation brief prior to all chase flights.

- What performance will the chase plane have?

The chase aircraft will have the performance required to keep the UAS in sight at all expected airspeeds and altitudes.

### **10. Safety Risk Management**

- An applicant must provide a hazard analysis that identifies and analyzes the hazards of UAS operations that are described in the program letter.

See Appendix G

- Additional information is available by contacting the FAA representative.

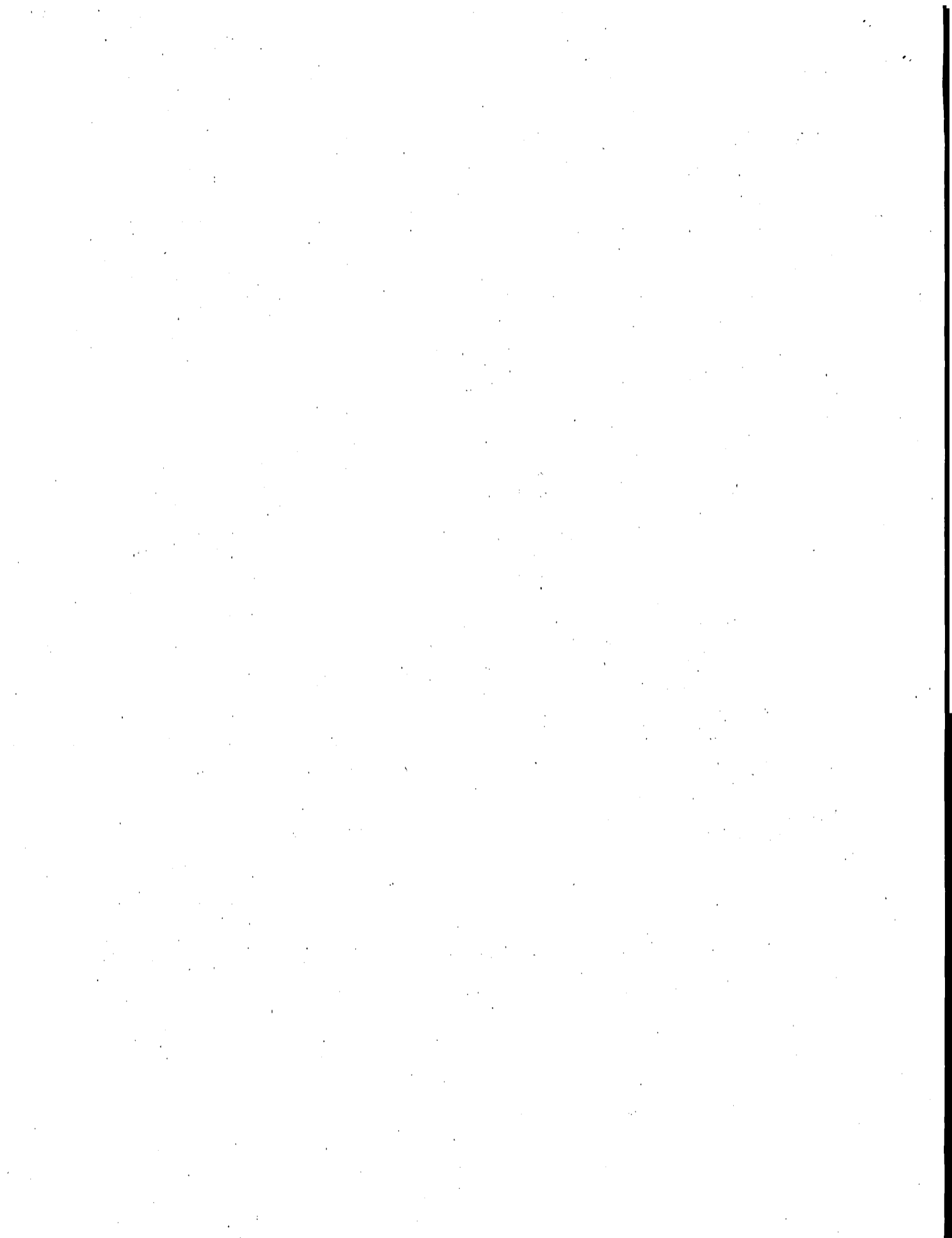

## 11. System Configuration

- Provide description of aircraft system configuration and all on-board and ground-based equipment.

Provided in paragraph 4, Aircraft Configuration. See Appendix F for a system diagram.

## 12. System Safety – Flight Termination and Lost Link

- What is the expectation of aircraft “Flight” if fuel is starved?

The system will provide the pilot with a visual and aural warning that the engine has failed. The aircraft will glide at the current commanded airspeed and continue to navigate to the next waypoint on the active flight plan. The backup battery system will continue to power the aircraft and all electrical systems in excess of one hour at maximum load. If altitude permits, the pilot will navigate the aircraft to a landing point of his choosing, and if video is available, he will use video to avoid obstructions on the ground.

- Describe/explain aircraft lost link and emergency recovery procedures.

- Command and Control

The Piccolo autopilot is programmed to fly to a “lost link” waypoint that is a point on a lost link flight plan. The lost link point can be changed during the course of the flight to follow the operational flight plan. The Pilot plans the lost link route to return to base at a safe altitude, and on a predictable flight path. The final 4 points on the lost link plan are looped to create a loiter pattern. If desired, the pilot can plan the lost link route to land the aircraft autonomously. The lost link timeout is set by the pilot during preflight. Raytheon procedure is to set the timeout to 10 seconds. During launch and recovery, the lost link point is set to a point on the departure end of the runway to prevent a turn close to the ground and in proximity to the GCS in case of lost link during the takeoff roll or during final approach.

A backup Piccolo GCS/datalink is available, and will be used in the event of GCS failure.

- Flight Termination

- In the event that datalink is lost and/or GPS becomes unusable, the Piccolo II autopilot can be set to automatically activate the flight termination function. The function will kill the engine, forcing a landing, or, if desired, can cause an aerodynamic termination. The details can be found in Appendix B, Piccolo II Users Guide. Raytheon sets this option to kill the engine if GPS fails. Figure 8 shows the settings available to the pilot for automatic flight termination. In Piccolo terminology, the “Deadman Line” is the ignition system.

Manual termination is done by killing the engine or selecting manual control and overriding the autopilot.

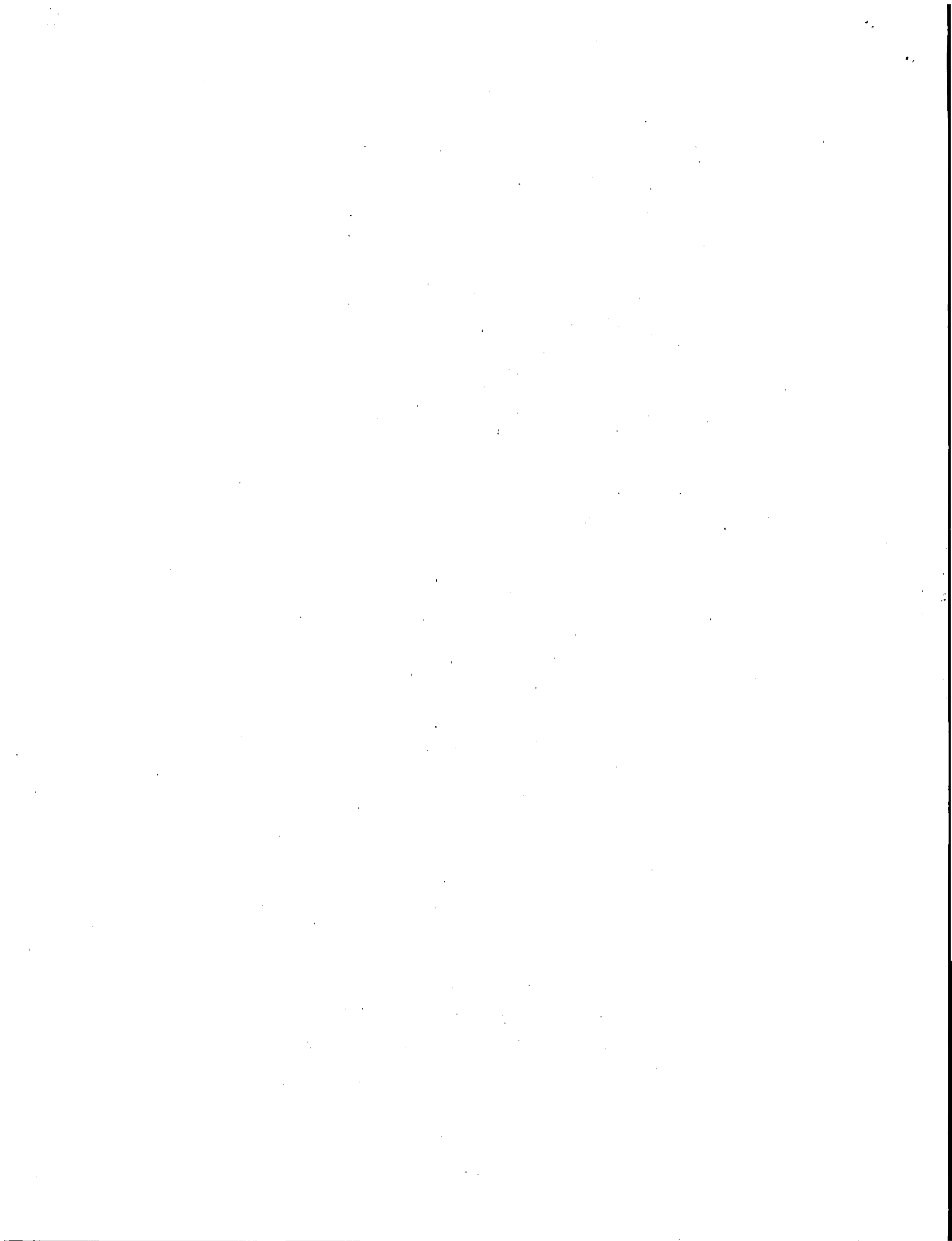

When the developmental datalink is installed, the Piccolo Microhard datalink can be used to sever the developmental link from the autopilot.

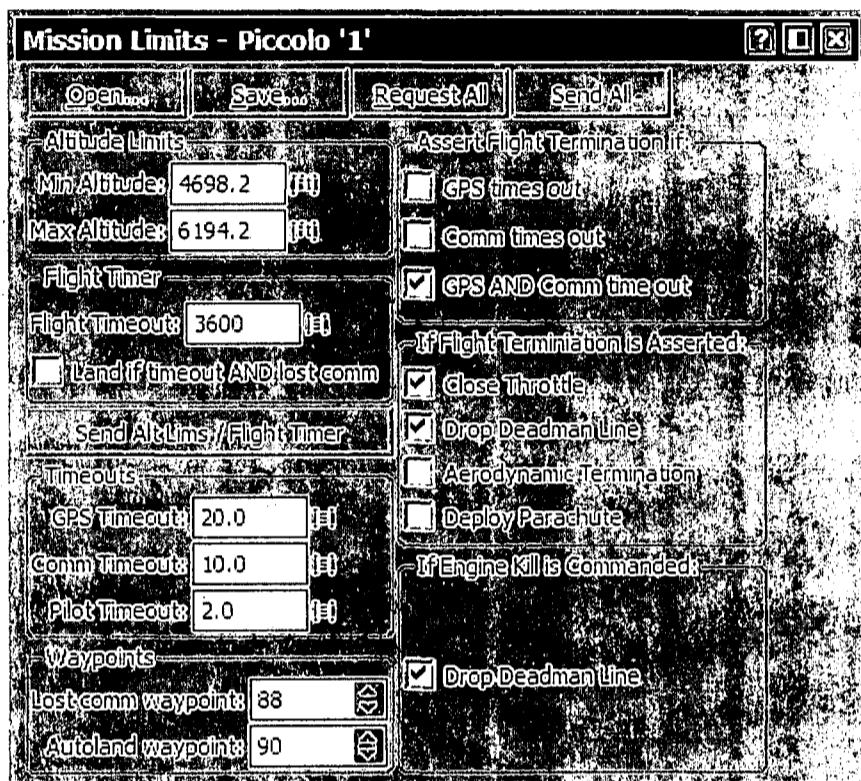
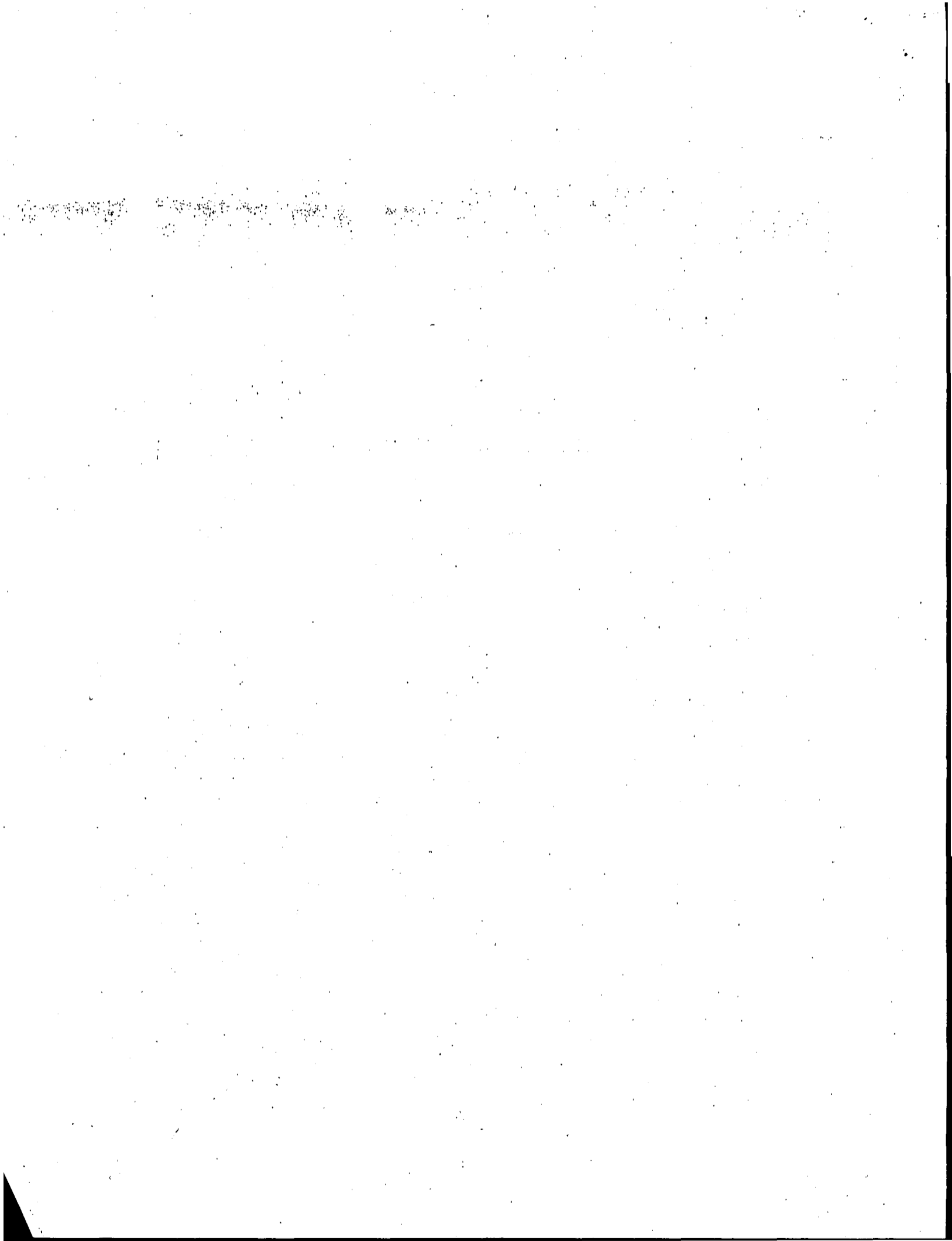

Figure: 6 Piccolo Flight Termination Settings

- o Loss of GPS

In the event that the GPS signal is lost, the autopilot will navigate by Dead Reckoning (DR) with the magnetometer installed, or execute Flight Termination as selected by the pilot. Visual and aural warnings are given to the pilot if navigation accuracy cannot be maintained. The pilot has the option of visually navigating to landing.







## 13. Command and Control

- Provide a description of the system and/or procedures for command and control of the UAS.

See Appendix C, Raytheon UAS Flight Manual

Cobra is manually taxied into takeoff position by the pilot or SP. The UA is launched by the pilot using Auto Takeoff. The pilot activates the takeoff by pressing the Launch button. The throttle is added slowly, and increases as forward speed is detected. The UA steers to centerline until rotation speed is reached at which time the autopilot raises the elevator for rotation. A climb rate is followed for a set time, and then switched to flight mode and the UA proceeds to the next waypoint in the takeoff flight plan.

The UAS can also be launched by the SP using manual control. Once the aircraft is airborne, the SP enters the pattern and verifies UA controllability. During the controllability check the SP trims the UA for hands off flight. The UA is then set to "Auto" mode, which sends the aircraft to a pre-planned flight route that duplicates the traffic pattern. This is done to observe the UA response to autonomous flight while still in visual range of the observer.

The route varies with the runway in use, but is overlaid on the landing pattern. The distance will be approximately 1/2 mile upwind or downwind at landing pattern altitude and 1/2 mile abeam. The Pilot is verifying health, status, and proper GPS tracking. The Supplemental pilot can take manual control with a switch on the manual controller if required. The Pilot can rapidly change the waypoint, altitude or airspeed, or can select a heading to fly.

The Pilot has several options with autonomous flight control. The flight plan controls the waypoint, turn type, slope, and altitude. The altitude hold can be overridden by the Pilot, while the aircraft continues to navigate to the selected waypoint. Airspeed hold is always set by the Pilot independent of the flight plan. During pre-flight, the Pilot sets minimum and maximum limits on the airspeed, altitude, pitch angle, and roll angle, which prevents the autopilot from exceeding safe limits. The airspeed and altitude hold command value cannot be set to exceed the limits.

If desired the Pilot can override the waypoint navigation and set the aircraft to maintain a turn rate, or heading. The Pilot can also select a waypoint for "Direct To" navigation. Any waypoint previously loaded can be selected. Also the pilot can select a "loiter now" function, where the aircraft orbits around its current position. Given the "point and click" map interface for setting waypoints, any waypoint can be quickly and easily moved by dragging it to a new position on the map.

Two stability augmentation modes are available to assist with the manual pilot console. Steering Mode overrides the waypoint navigation allowing the SP or Pilot to steer the aircraft with the manual control stick, while maintaining airspeed and altitude hold. The manual control stick commands a turn rate proportional to the amount of stick deflection. Full Authority mode overrides waypoint navigation, altitude, and airspeed hold using the manual pilot console. Steering is accomplished the same as in Steering Mode, Altitude is set by throttle command, and airspeed is set by pitch command. For airspeed, the stick

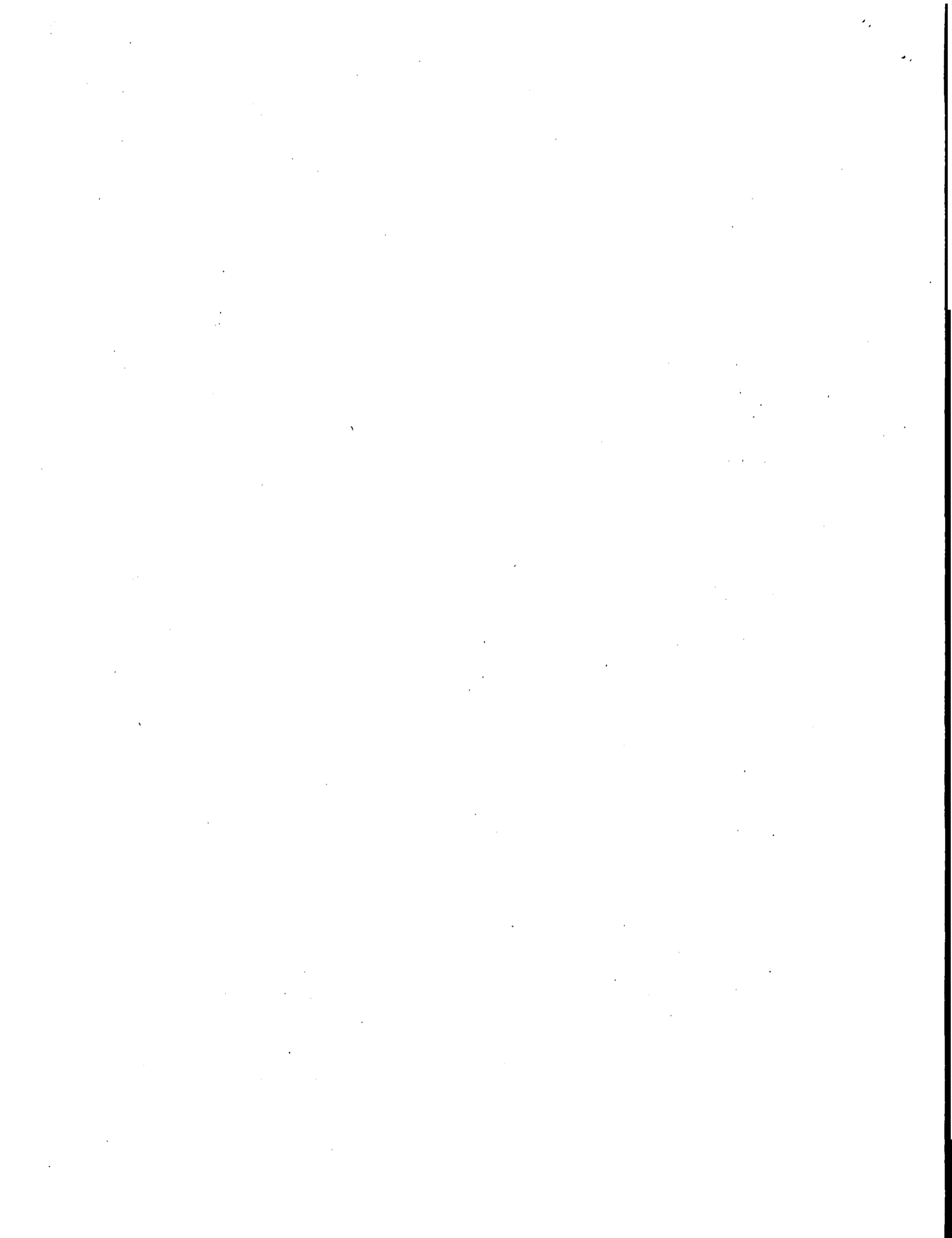

## Raytheon

neutral pitch position will keep the UA at the current commanded airspeed hold, while pitch down/up will increase/decrease the airspeed proportional to the amount of stick deflection.

When required, the SP or Pilot can disconnect the autopilot from the flight controls by selecting manual control on the manual pilot console. All telemetry is available during manual operation.

When the flight is complete, the Pilot sends the UA to the pre-planned landing route. This is the Autoland function. These waypoints are designed to fly a landing pattern of a pre-selected length and glideslope to a specific landing point. A flair altitude and speed is set, and there is an option to kill the engine at the flair altitude. The pilot can select "go-around" with the push of a button which forces the aircraft back to the first point of the landing plan, or he can select any other waypoint or flight mode as described above. This is the normal landing mode for Raytheon.

If the Pilot chooses, he can use the stability augmentation modes to fly the pattern using his telemetry, instrumentation, and video to land the UA.

The RC controller is hard wired to the datalink for the Supplemental pilot. At any time he can take manual control by a switch and land using the manual controller.

### 14. Control Stations

- Provide a description of the ground/airborne stations used to control the UAS.

The GCS is composed of 1-4 laptop computers, a ground datalink module, and a power supply. These can be used in any shelter, or in the open. The manual pilot console is connected directly to the ground datalink module, and remains functional in the event of computer failure. Raytheon uses a panel truck to house all the equipment and provide environmental protection. An intercom system is installed allowing for crew communications during flight. An aviation band VHF radio is connected so that all voice communications are heard by the flight and ground crews. All video and voice communications are recorded onto a digital recorder.

The minimum configuration for flight is a laptop with the Piccolo Operator Interface (OI) pilot console software, the Piccolo ground datalink module, and Piccolo manual pilot console. The Piccolo OI has a moving map display, and screens for commanding all modes of flight and for observing all status telemetry received from the UA. See Appendix B. The maps used by Raytheon for the Piccolo OI are exported from the Falcon View PFPS route planning software. Falcon View is updated with current ECHUM and DAFIF information on a 28 day cycle. All telemetry files are logged onto the computer, and are archived during postflight. Visual and audible alarms are used to warn the operator of RPM, Altitude, Airspeed, System, Datalink (Comms) and GPS errors. There are additional data points in the displayed telemetry, but these are the only ones with an alert.

Additional computers can be added and networked together for additional functionality. MVCS consisting of a CUCS and VSM can be connected giving the pilot a virtual MFD. The CUCS pilot console has a moving map display, a PFD, and other displays for

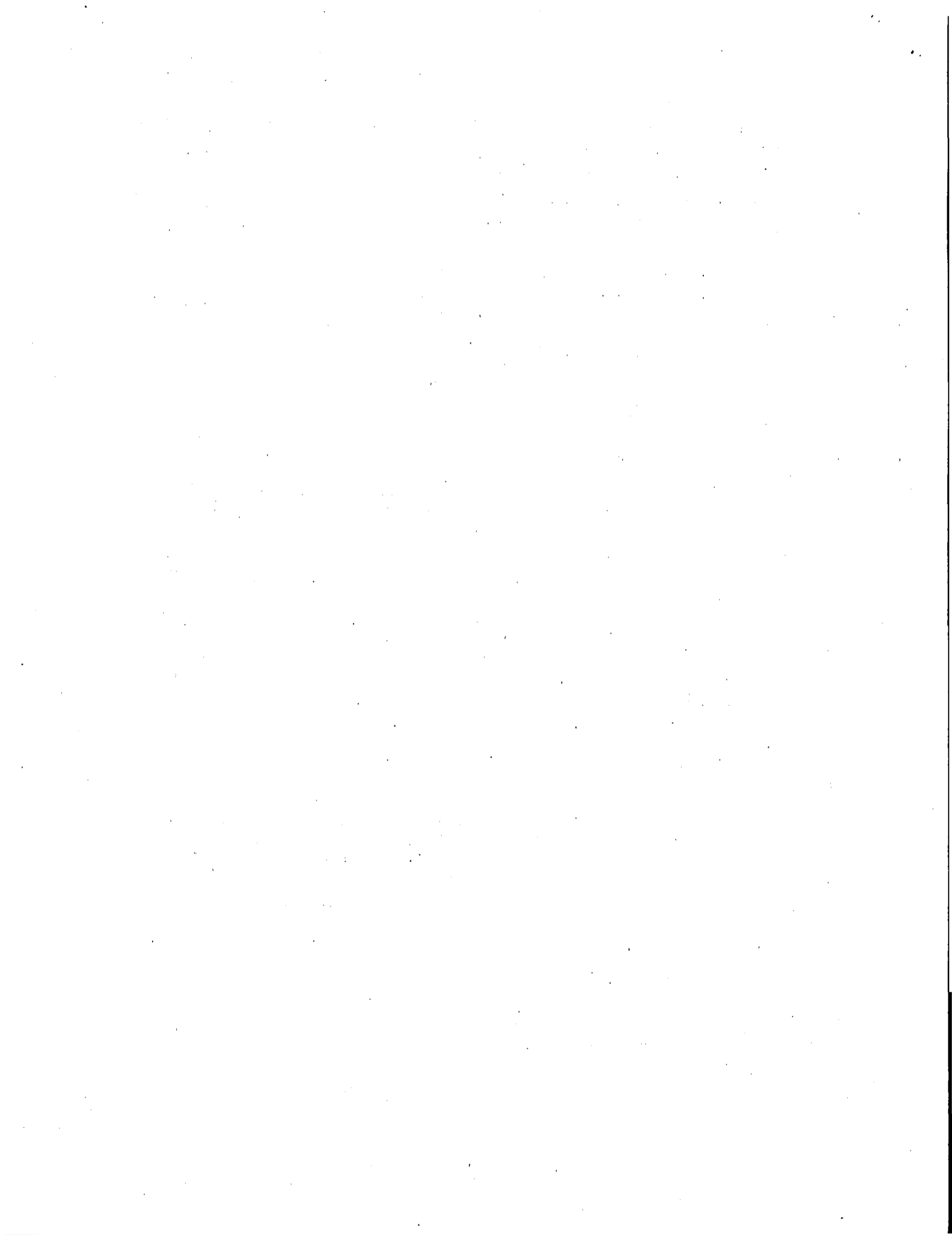

# Raytheon

commanding all flight modes and receiving all status telemetry and the moving map display will show the location of every UA on the network. The VSM can be hosted on the GCS computer or in the ECM aboard the UA.

Both the Piccolo OI and the MVCS can manage up to 4 aircraft simultaneously, or a pilot console can be added to the network for each UA.

## 15. Control Frequencies

- Provide a description/listing of the frequencies used to control the UAS.
  - o Microlight (Raytheon) Datalink
  - o Primary: 420-450 MHz
  - o Microhard (Piccolo) Datalink
  - o Secondary: 902-928 MHz
- Video Datalink
  - o Blackwidow 2.4 GHz
  - o <http://www.blackwidowav.com/bwav240200urban.html>
  - o GMS 2.4 GHz
  - o [http://www.gmsinc.com/product\\_details.asp?prod\\_idno=105](http://www.gmsinc.com/product_details.asp?prod_idno=105)
- Frequency Manager Points of Contact:
  - o FAA Western Pacific Region  
Frequency Management Officer  
AWP-471  
Sidney Bradfield  
Federal Aviation Administration, Western-Pacific Region  
15000 Aviation Boulevard  
Hawthorne, CA 90250  
310-725-3671  
[sydney.bradfield@faa.gov](mailto:sydney.bradfield@faa.gov)
  - o

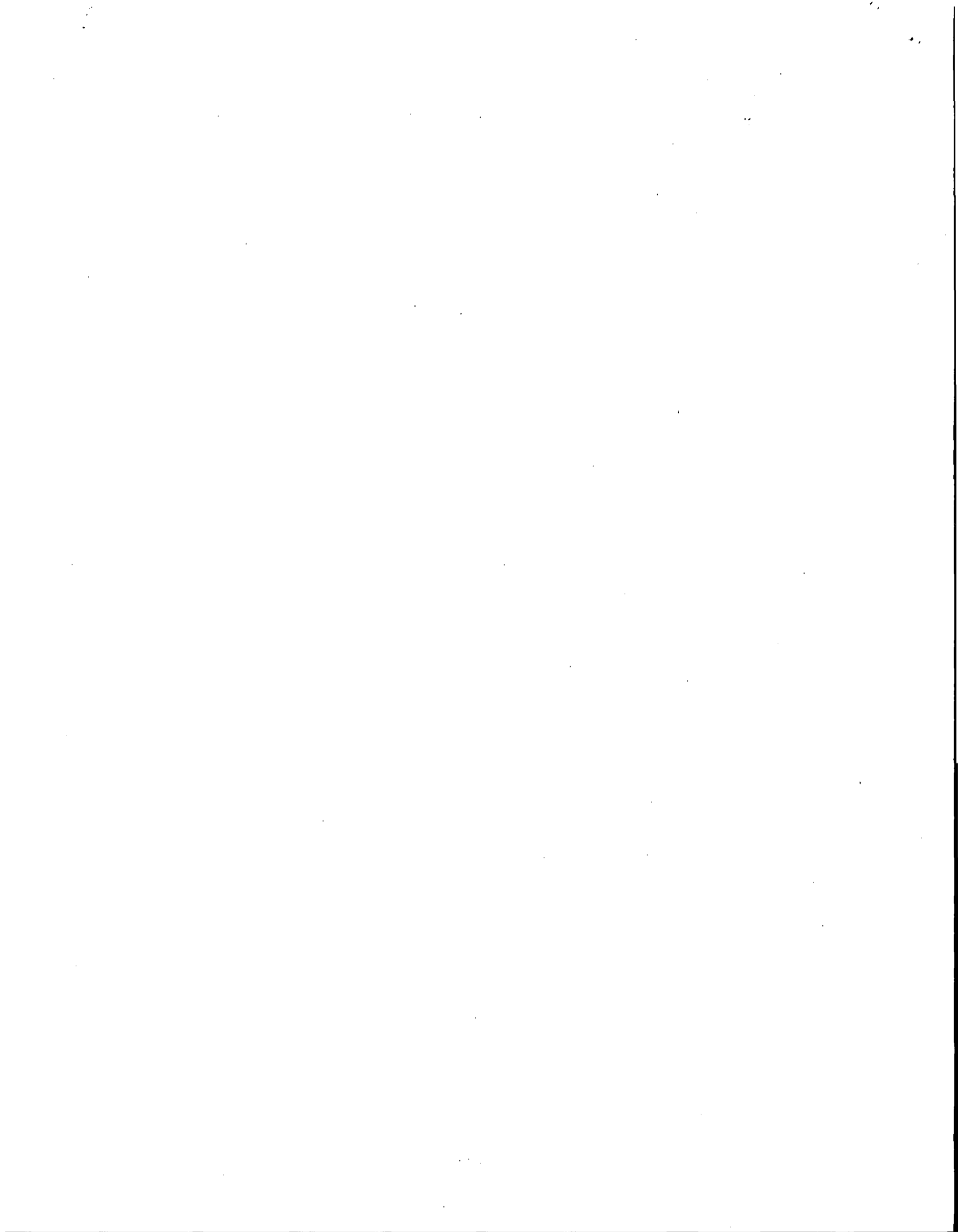

## Raytheon

- DoD Area Frequency Coordinator State of Arizona

Rod Hanson

Arizona Ave Bldg 85846

Ft. Huachuca, Arizona 85613-5000

520-538-6423

[rodney.hanson@us.army.mil](mailto:rodney.hanson@us.army.mil)

- Raytheon Frequency Coordinator

Thomas J. Fagan

Raytheon Missile Systems

E3 & Spectrum Management

P.O. Box 11337

Bldg M02 M/S T16

Tucson Arizona 85734-1337

520-794-0227

[tjfagan@raytheon.com](mailto:tjfagan@raytheon.com)

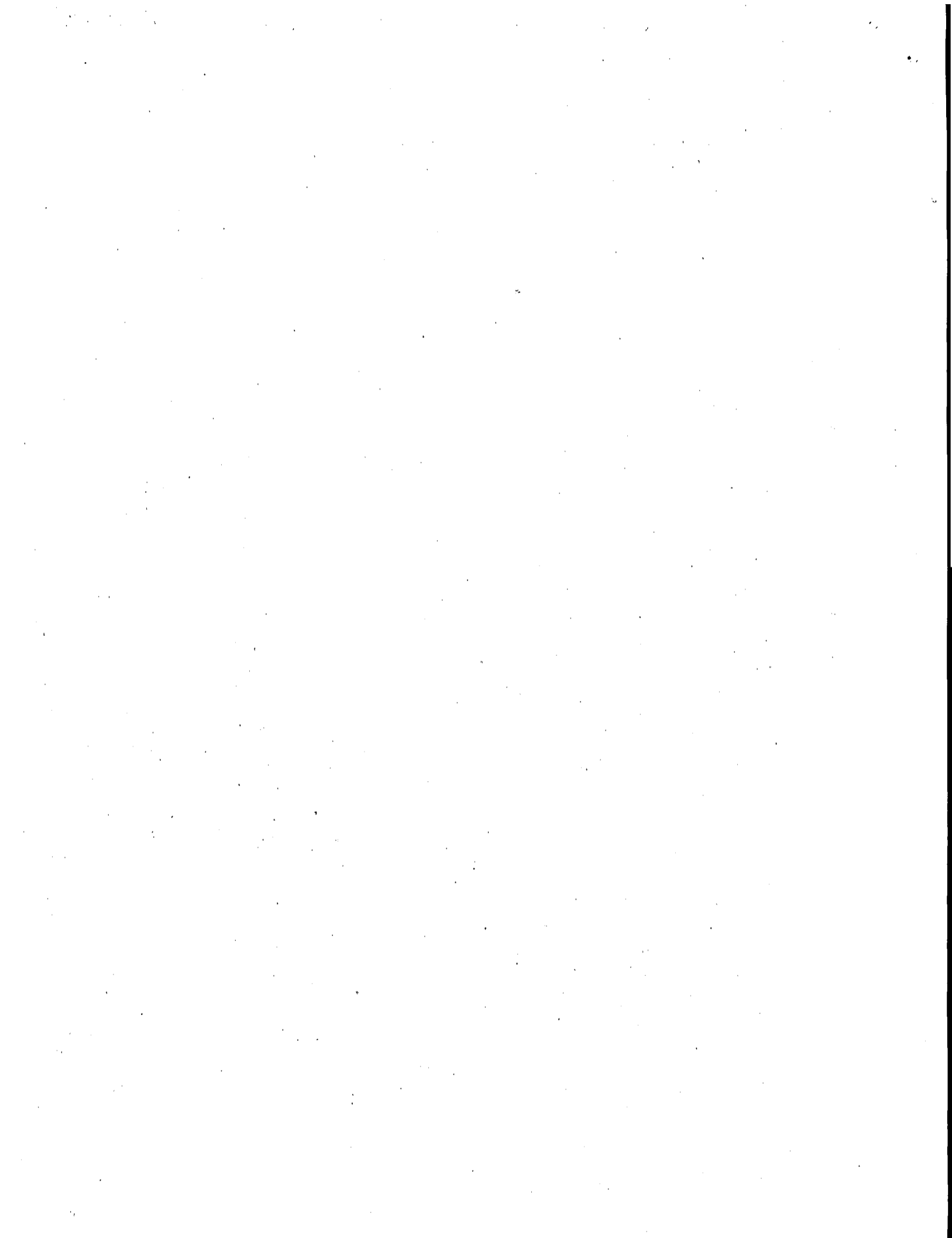



*Appendix A - Cobra Drawings and Photographs*

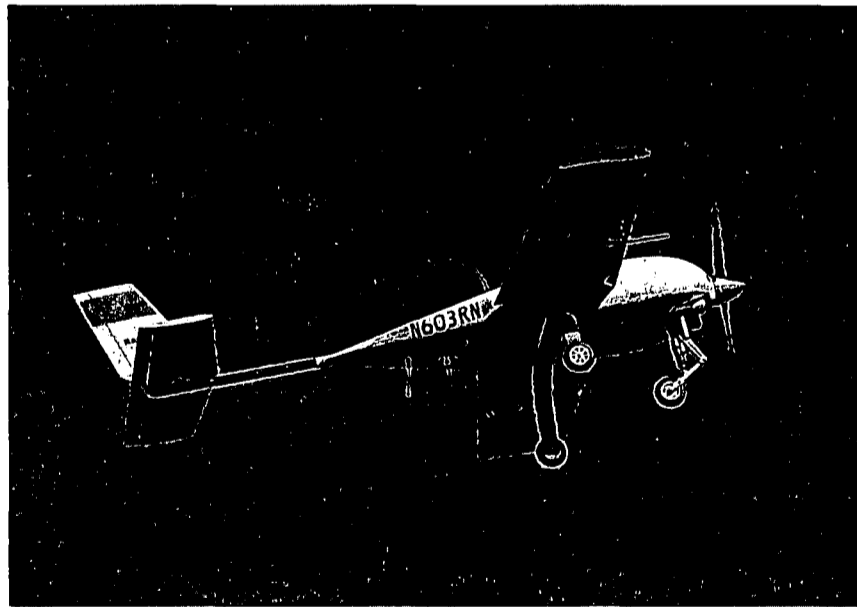
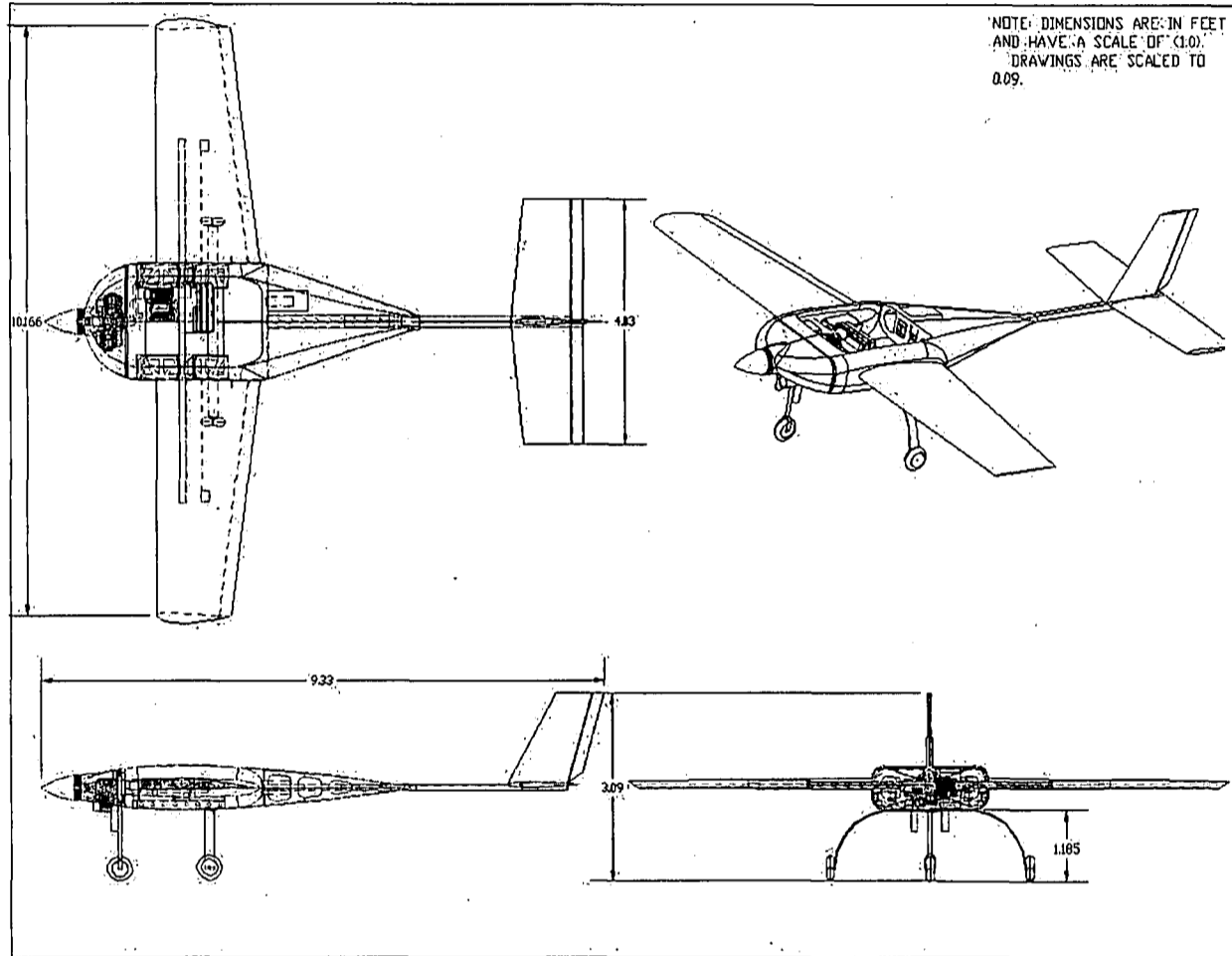

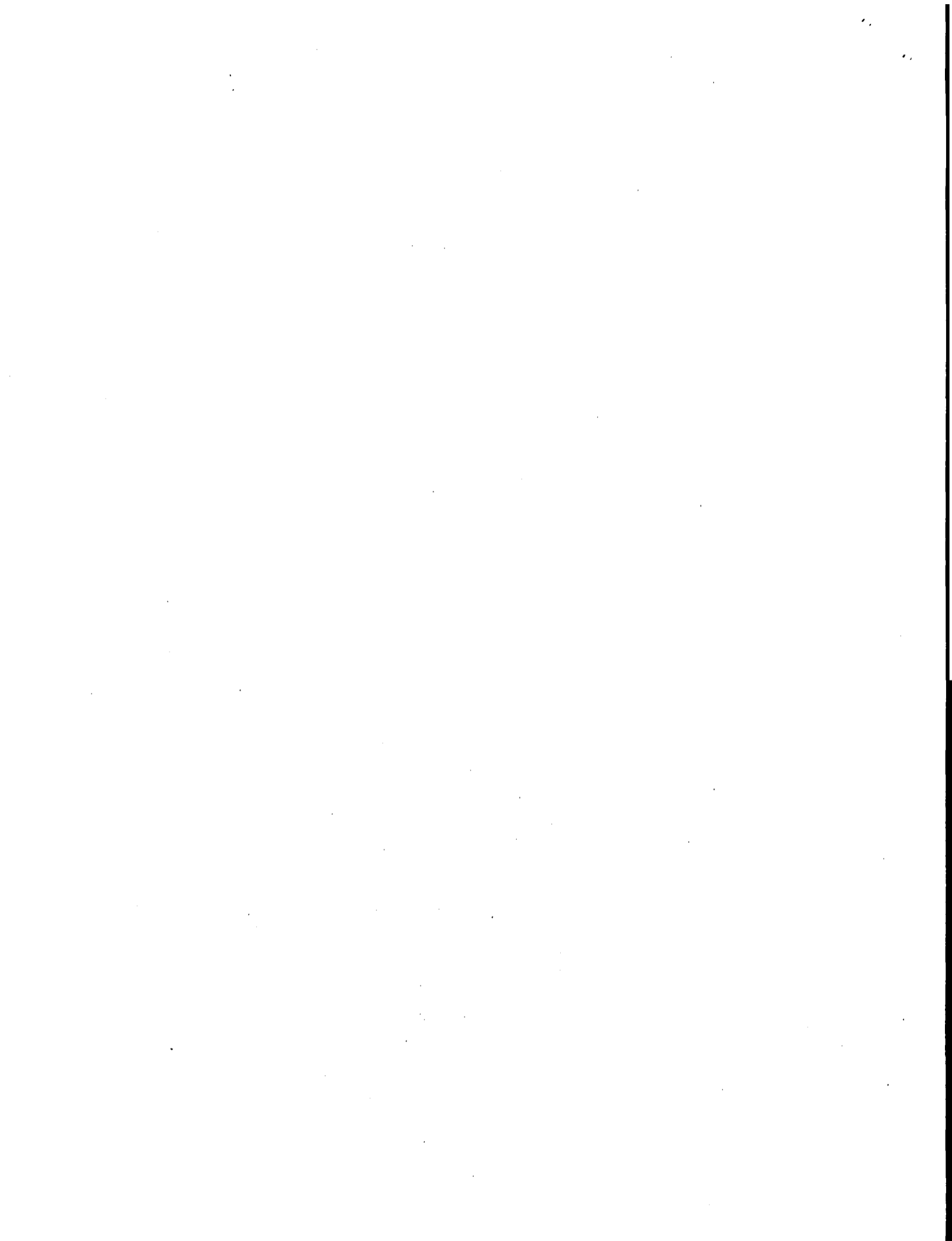

**Raytheon**

*Appendix B - Cloud Cap Piccolo II Users Guide*

Separate Document

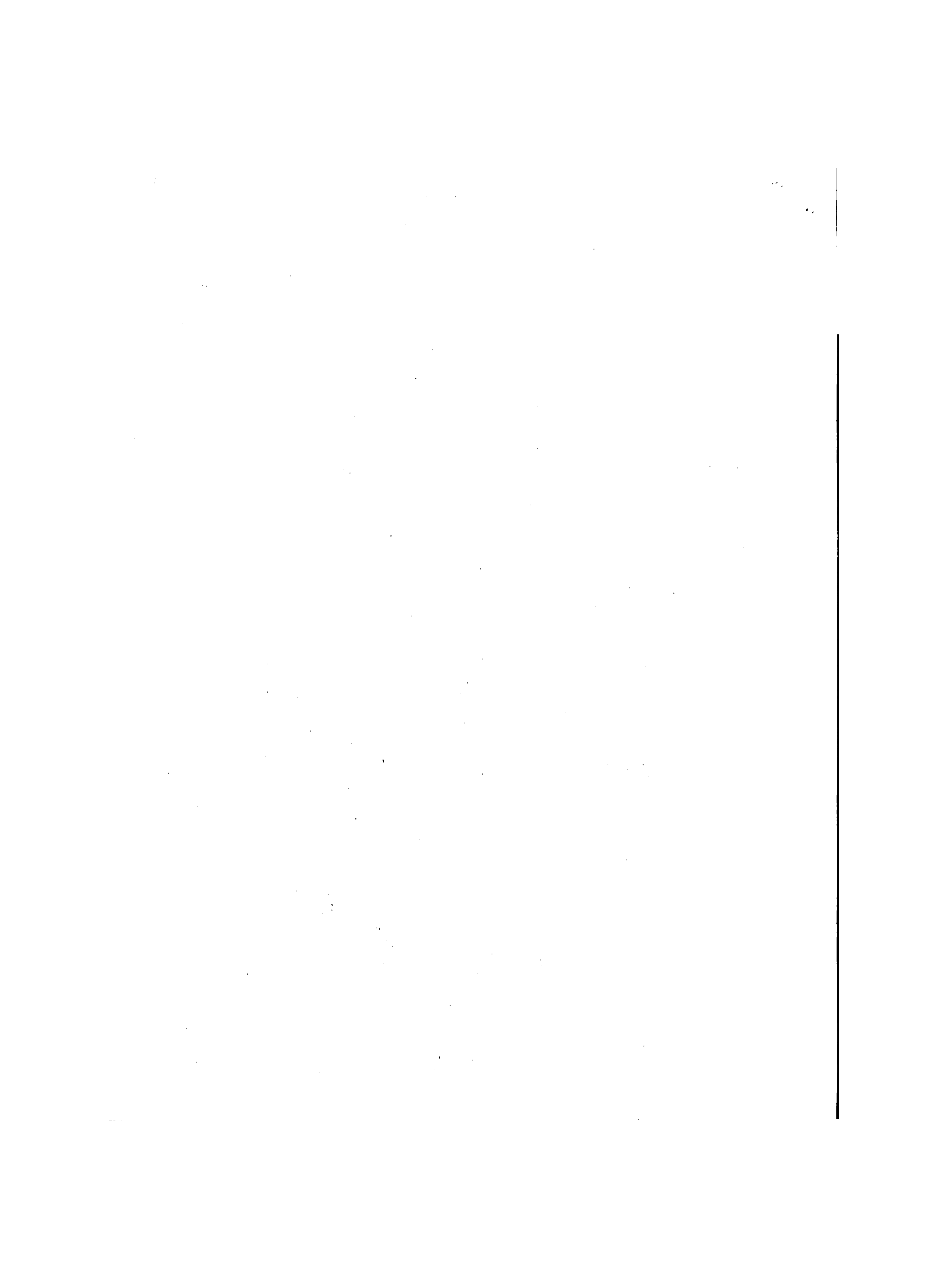

## Appendix C - Raytheon UAS Flight Manual

Separate Document

### Appendix D - Cobra Weight and Balance

This is a preflight planning tool. It is not real-time, in that the "system" does not constantly compute the CG based on fuel burn. The Wt and Bal is conducted before each flight based on the weight and arm of the variable items. Given the test nature of our operations, Raytheon will conduct a full weighing of the aircraft before a flight if required.

COBRA

Raytheon UAS Weight and Balance			
AIRCRAFT	Cobra N601RN		DATE
MAX T/O WEIGHT	105.0	Datum 0=Spinner Nose	
MAX USEFUL LOAD	33.4		
MAX PAYLOAD W/FUL FUEL	18.6		
	WEIGHT	MOMENT/1000	ARM
EMPTY WEIGHT	61.60	11.81	19.00
Balls	0.00	0.00	0.00
Center Ballast	0.00	0.00	0.00
Battery	1.45	0.00	18.25
Payload Tray	1.85	0.00	23.75
Air Data Probe	0.00	0.00	0.00
Air Video Tx	0.00	0.00	0.00
TASE Payload	0.00	0.00	0.00
Navstar	0.62	0.00	29.13
	0.00	0.00	0.00
Left Fuel (Enter Gal)	0.75	1.65	23.75
Right Fuel (Enter Gal)	0.75	1.65	23.75
<b>TOTALS</b>	<b>74.85</b>	<b>2.15</b>	
<b>CG</b>	<b>28.60</b>		

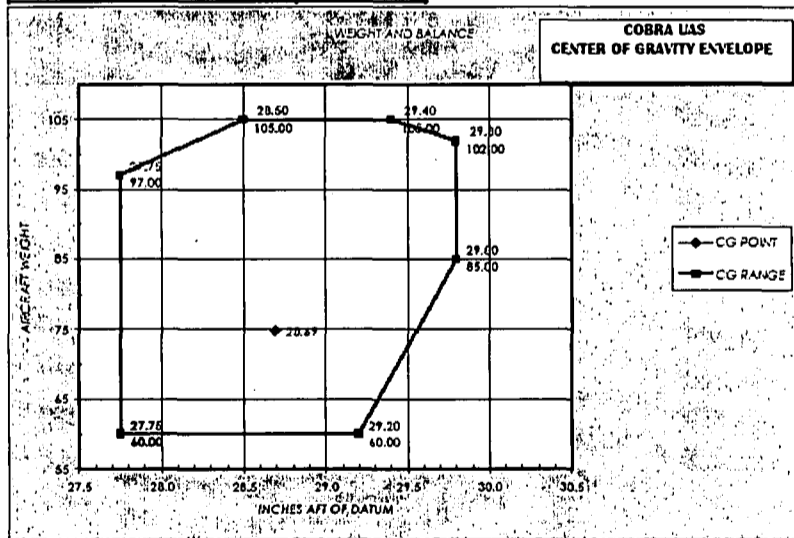

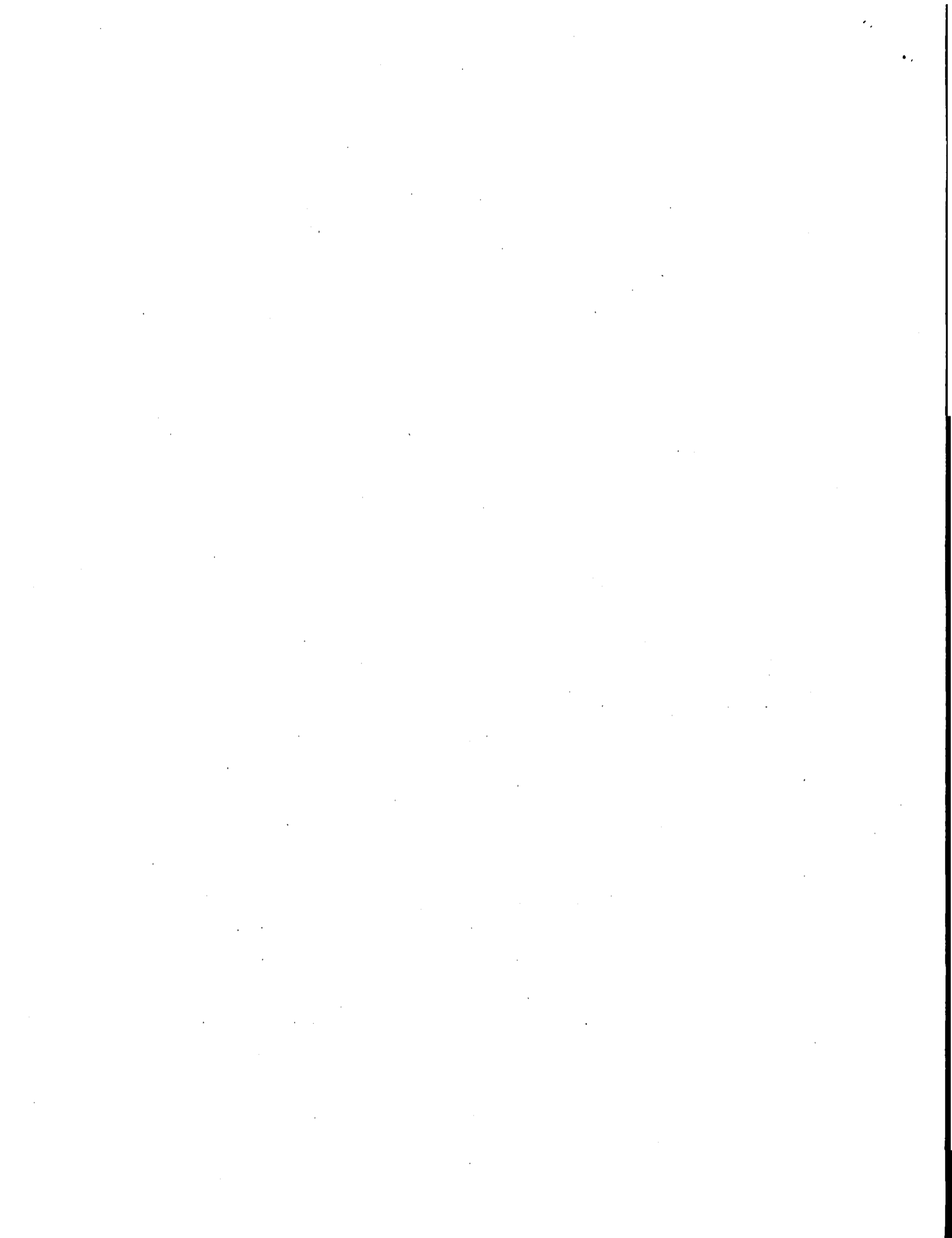

# Raytheon

## Appendix E - Minimum Equipment List

The Minimum Equipment List (MEL) for this UAS will be used to show optional equipment configurations. Since all flight operations will be done in day VFR conditions, there will not be an option for night operations. However, the difference between a local flight and a range flight beyond 1 NM from the launch site will be delineated.

R – Required N – Not Required

Sub-System	Local Flight	Range Flight
Piccolo II Autopilot	R	R
Brakes	R	R
Generator	R	R
Regulator	R	R
Strobe Light	R	R
Transponder	R	R
Altitude Encoder	R	R
Magnetometer	R	R
Piccolo GCS	R	R
Manual Pilot Controller	R	R
MVCS	N	N
MicroHard Datalink and Antenna	R	R
MicroLight Datalink and Antenna	N	N
NetFires Datalink and Antenna	N	N
Video Transmitter and Antenna	N	N
Video Camera – Fixed	N	N
Video Camera – Gyro-Stabilized	N	N
Embedded Computer Module	N	N
DA-150 16 Hp Engine (W/Ign Module)	R	R
150 Muffler Set (W/Bolts, Gaskets, Plug Screws)	R	R
Mejlik 30x12 Propeller	R	R
IGN Sensor	R	R
RPM Sensor	R	R
Hitec Hsc-5955 Titanium Gear High Speed Servo S	R	R

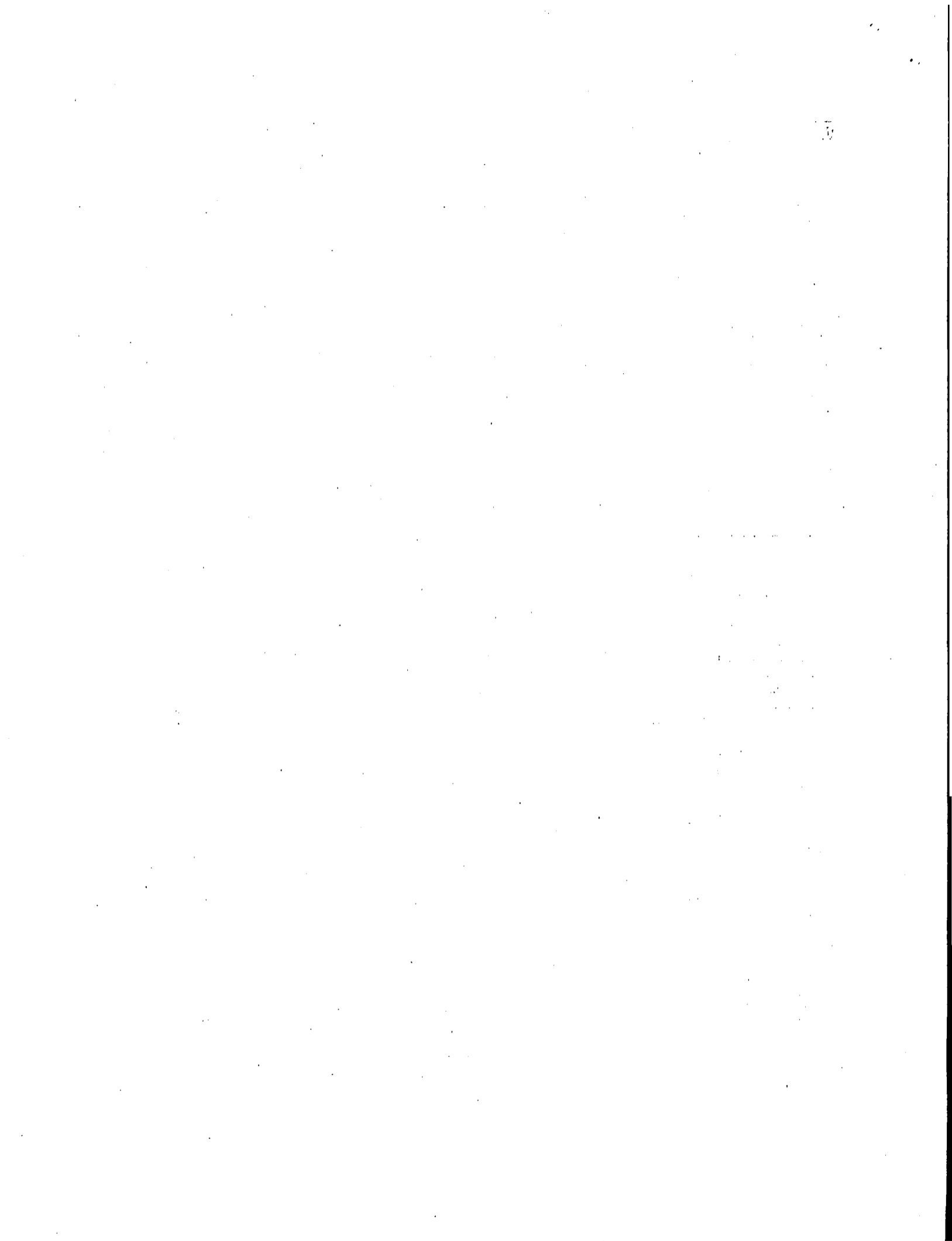



## Raytheon

Robart 168 Fill Valve/Fill Chuck	R	R
Dubro In-Line Fuel Filter	R	R
Robart 192 Large Pressure Tank	R	R
Dubro Dura-Collars 3/16" (4)	R	R
Robart 173 On Board Pressure Gauge	R	R
SLA 1.6 Gallon Tank	R	R
Dubro Fuel Tank 1500cc 50 Oz.	N	N
Fourmost Fitting Tee Large (4)	R	R
Sullivan Aluminum Nipple Fitting	R	R
Dubro Tygon Gas Tubing	R	R
Dubro Heavy Duty Ball Links 4-40 (12)	R	R
Dubro Threaded Rod 4-40 12" (24)	R	R
Sullivan UAV Generator W/Regulator	R	R
Trailing link shock strut nose gear	R	R
Brake Hub Set For The 5" To 6" Tuff Tread Aluminum Wheels	R	R
8 Spoke Brake Hub 6"	R	R
Heavy Duty Switch Harness With Charge Jack	R	R
GPS Cable Long SMA - Push On	R	R
GPS Cable Short SMA - SMA	R	R
Engine Mount Standoffs	R	R
Dzus Fasteners For Payload Hatch	R	R
Landing Gear Main Strut	R	R
I Hooks Hold Down Bolts	R	R
Nylon Tail Boom Attach Bolt	R	R
Engine Mount Bolts	R	R
Main Gear Attachment Hardware	R	R
Large Washer For Nose Wheel Strut	R	R
Dust Cover Cap For Air Fill Port	R	R
Brackets For Anti -Rotation	R	R
Nose Wheel Strut Mounts	R	R

1. The first part of the document discusses the importance of maintaining accurate records of all transactions. It emphasizes that this is crucial for ensuring the integrity of the financial statements and for providing a clear audit trail. The text notes that any discrepancies or errors in the records can lead to significant complications during an audit and may result in legal consequences for the company.

2. The second part of the document outlines the specific procedures that should be followed when recording transactions. It details the steps from identifying the transaction to the final entry in the accounting system. The text stresses the need for consistency and accuracy in the data entered, as well as the importance of reviewing the records regularly to catch any mistakes early on.

3. The third part of the document addresses the role of internal controls in the recording process. It explains how these controls help to prevent and detect errors or fraud, thereby protecting the company's assets and ensuring the reliability of the financial information. The text provides examples of common internal controls and discusses how they should be implemented and monitored.

4. The fourth part of the document discusses the impact of technology on the recording process. It highlights the benefits of using accounting software, such as increased efficiency and reduced risk of human error. However, it also notes the importance of ensuring that the software is properly configured and that the data is backed up regularly to prevent loss.

5. The fifth part of the document concludes by summarizing the key points discussed and reiterating the importance of a robust recording system. It encourages the company to regularly review and update its procedures to stay current with best practices and regulatory requirements. The text ends with a statement of confidence that a well-implemented recording system will contribute to the overall success and financial health of the organization.

## Raytheon

Nose Wheel Steering Control Arm	R	R
GPS Antenna	R	R
GPS Filter	R	R
Pitot/Static Tube	R	R
Prop Bolts	R	R
Spinner Bolt	R	R
Panel Mount Mini-Din Connector For Brake Controller Unit (5-Pin Elliott)	R	R
Male 5 Pin Din	R	R
Female 5 Pin Din	R	R
4-40 Metal Clevis	R	R
Deans Connectors	R	R
Control Horns Wing, Elevator, Rudder	R	R
Inline Futaba Connectors And Ext Cables	R	R
Inline Air Fitting For Pitot Tube Hoses	R	R
RED & BLACK Anderson Type Connectors (Ign Pwr, Eng Kill)	R	R
Servo Mount Blocks For Throttle Servo And Steering Servo	R	R
Mounting Provisions For Servos Installed In Tail Surfaces	R	R
NACA Air Scoop	R	R
Aft Fuselage Exhaust Vent Assembly	R	R
Power Control Module	R	R
SLS Pitot Tube Housing	R	R
Payload Tray For Ballast CG Testing	N	N
Spacer In Nose Wheel Strut To Compress Spring	R	R
Rubber Shock Mounts For Gen Voltage Regulator	R	R
Piccolo Connector (44 Pin)	R	R
SMA Feed Thru For Piccolo UHF Antenna	R	R
Piccolo UHF Antenna Coax SMA-SMA	R	R
10 K Ohm Resistor For Rpm Sensor	R	R
Hose Clamps For Pitot Tubes	R	R

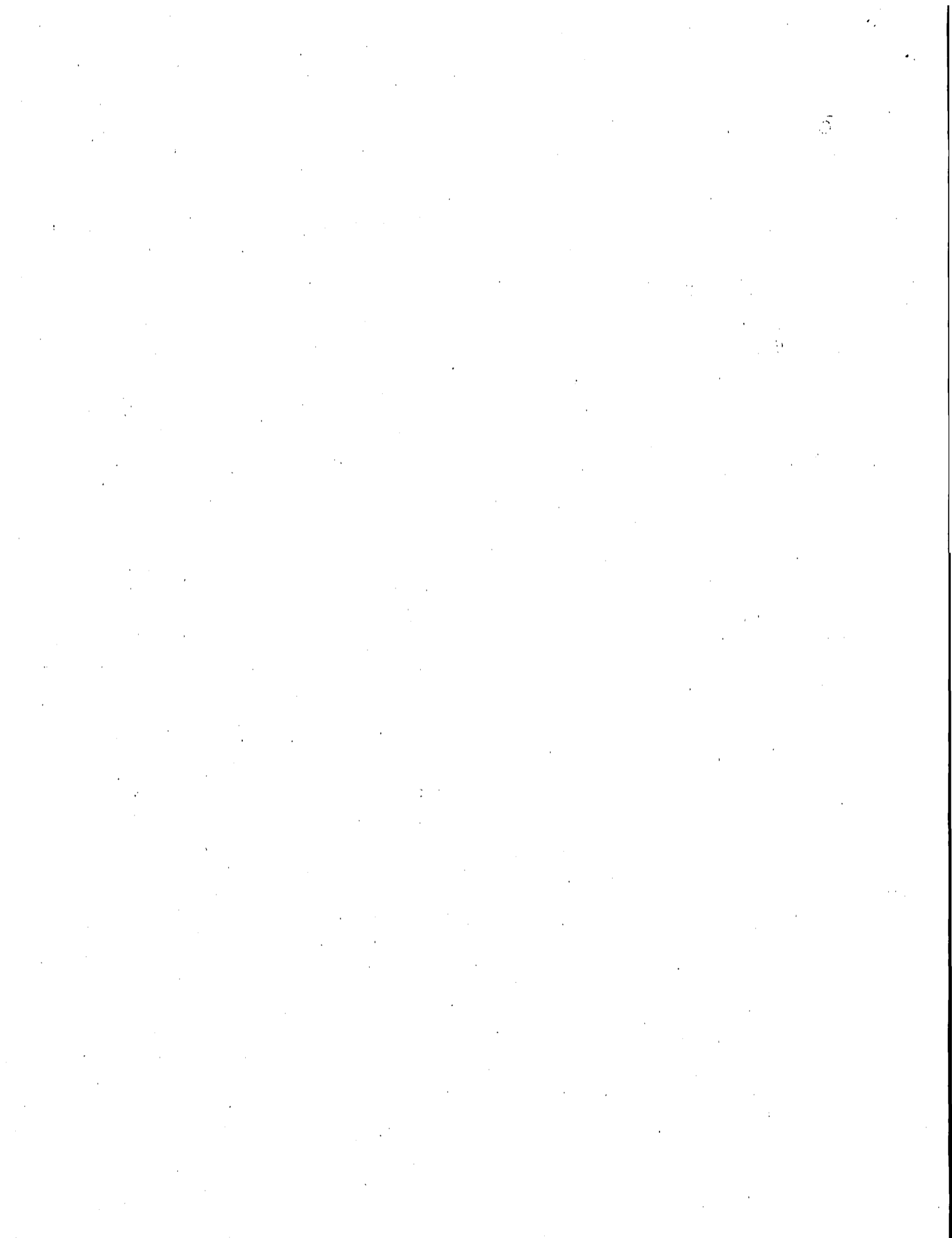

## Raytheon

Connector For Piccolo II Payload Port	R	R
Metal Threaded Inserts In Wings To Secure Pitot Tube Housing	R	R
Bud Box For Brake Controller Unit 3.5 X 1 5/8 X 2"	R	R
Tail Skags (Great Planes, Aka Wingtip Skids)	R	R
Tail Boom Carbon Wrapped Tube 6' 1.0" ID,0.06" WT,56 G./Ft.	R	R
Wing Spar 1.25" ID, Cello-Wrapped.	R	R
Ballast Weights	N	N

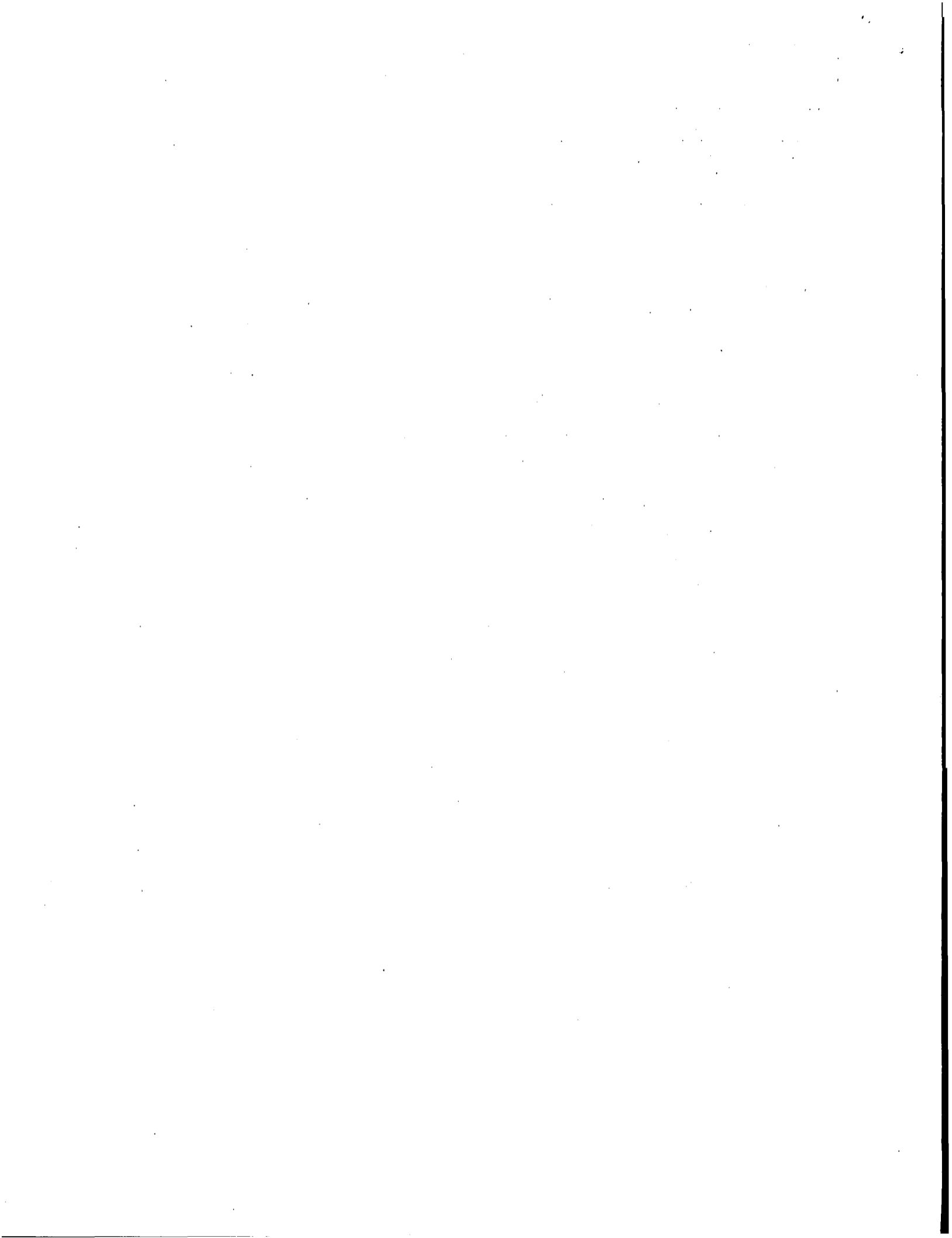

## Appendix F - System Configuration Diagram

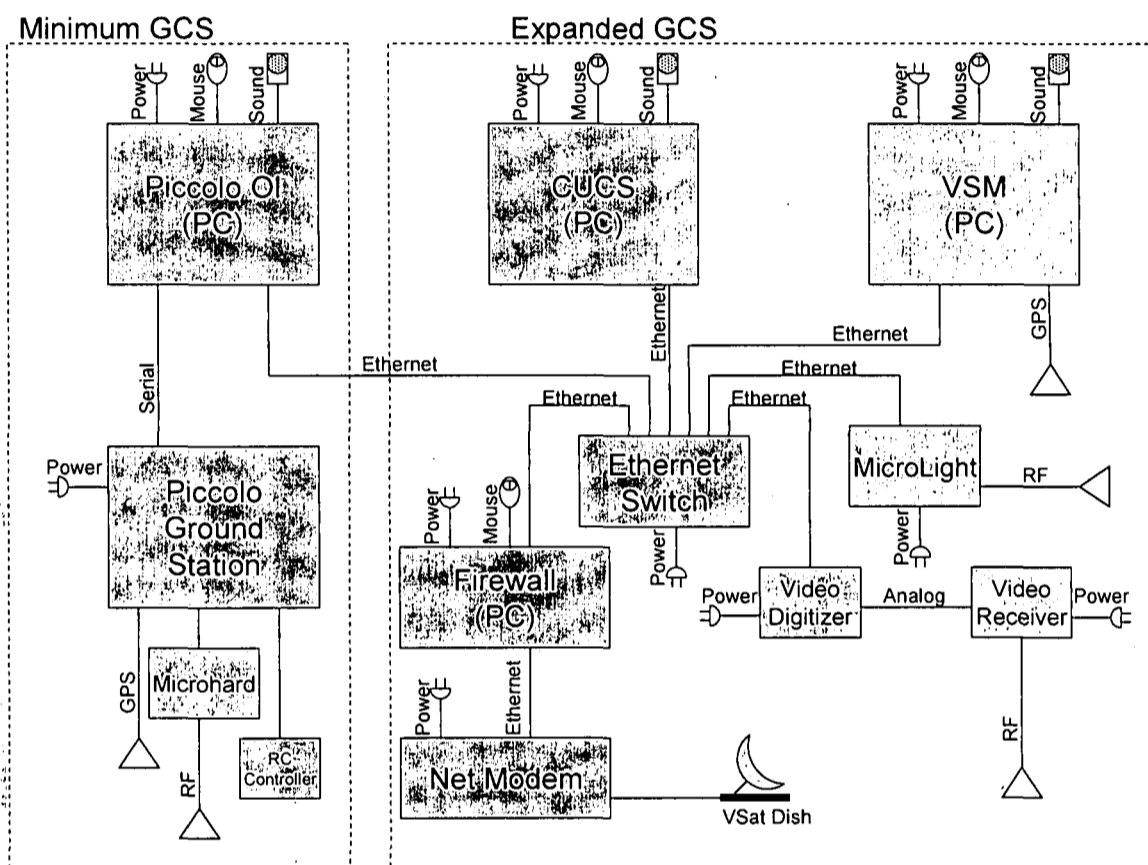

### A Minimum GCS

This is the basic Cloud Cap Piccolo Ground Station delivered by the autopilot manufacturer. Can operate as a stand alone Ground Control Unit, or be expanded via ethernet connection. External power is provide by a 1500 watt Uninterruptible Power Supply (UPS) (not shown).

<http://www.cloudcaptech.com/>

#### 1 Piccolo Operator Interface (OI)

- (a) Pilot and Sensor interface (software) running on a laptop PC. Windows Operating System. Connects to Piccolo Ground Station Module via serial interface.
- (b) Laptop contains battery backup.
- (c) Connects to Expanded GCS via Ethernet.

#### 2 Piccolo Ground Station (Module)

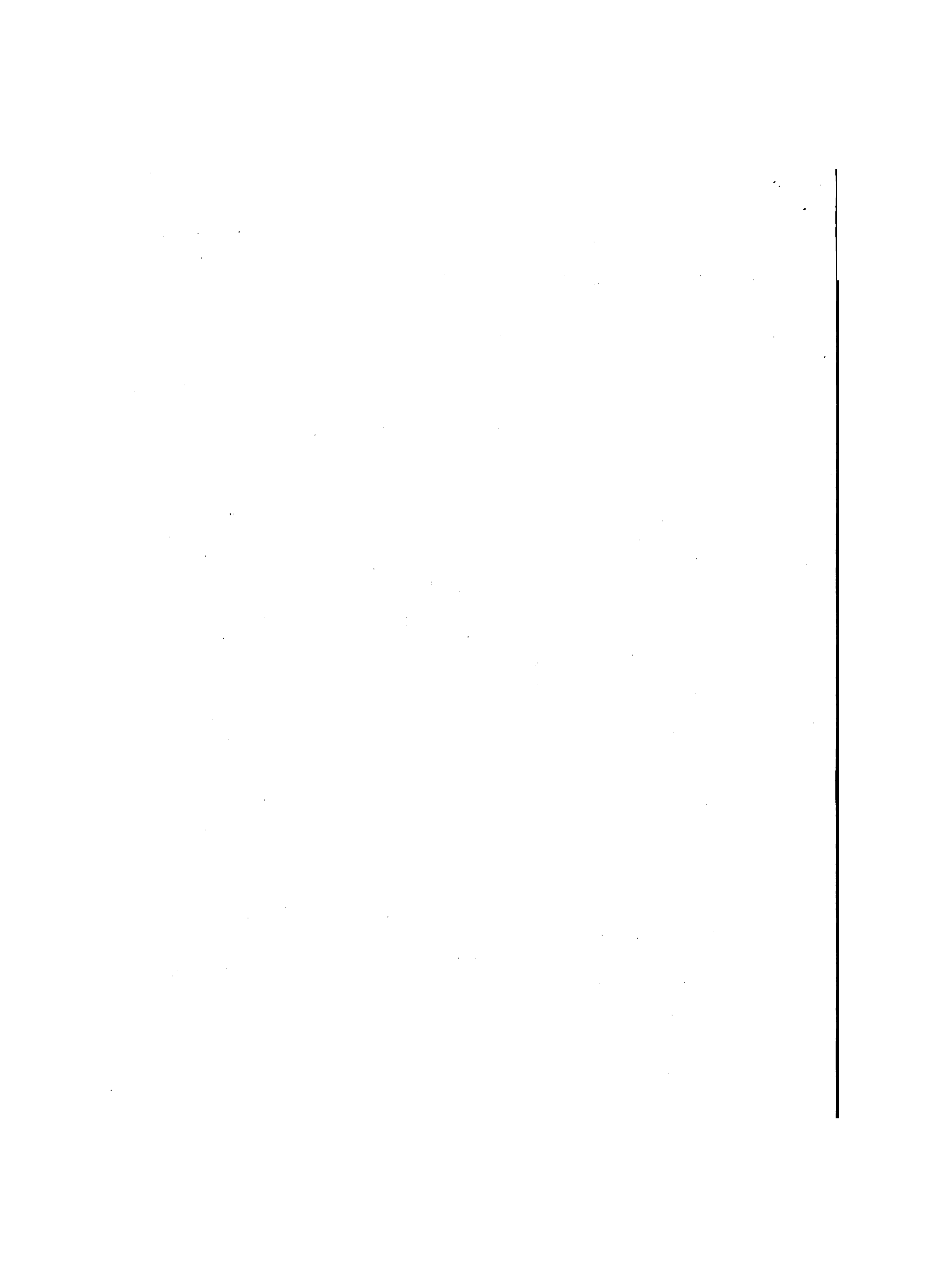



# Raytheon

- (a) An enclosed 8x6x4 hardware unit consisting of a Piccolo Autopilot Card, GPS, Microhard Transmitter/Receiver, and internal battery backup.
- (b) Connects to and provides power for the RC controller, and provides external antenna connections.

### 3 Microhard Datalink

- (a) Internal to the Piccolo Ground Station Module. Provides 1 watt transmit and receive on 900 MHz spread spectrum datalink.
- (b) Passes command and control inputs to, and receives telemetry data from the aircraft
- (c) <http://www.microhardcorp.com/>

### 4 RC Controller

- (a) A standard off the shelf Remote Control (RC) model controller with the battery and TX/RX module removed. Connected to the Ground Station module via the buddy cord interface. Receives power from the Ground Station module. Provides manual pilot control of the aircraft, and switches from manual to automatic control.
- (b) Is not required for system function. If disconnected, and configured correctly, the system defaults to automatic.

## B Expanded GCS

Multi-Vehicle Control System (MVCS), MicroLight datalink, extended communications and video processing. External power is provide by a 1500 watt UPS (not shown).

### 1 Common UAS Control System (CUCS)

- (a) Sub-component of the MVCS
- (b) One of two STANAG 4586 compliant modules. Pilot and Sensor interface (software) running on a laptop PC. Linux Red Hat Operating System. Connects to Piccolo OI via ethernet interface.
- (c) Can run on the same laptop as the VSM or independently.
- (d) Multiple CUCS can be connected via the ethernet hub to provide additional pilot or sensor controls.
- (e) STANAG 4586 – NATO standard for UAS communications
- (f) Laptop contains battery backup.
- (g) Can be configured to use the Microhard datalink or the MicroLight datalink.

### 2 Vehicle Specific Module (VSM)

- (a) Sub-component of the MVCS
- (b) Second of two STANAG 4586 compliant modules. Telemetry interface (software) running on a laptop PC on an airborne processor. Linux Red Hat Operating System. Connects to CUCS via ethernet interface or to aircraft via datalink.
- (c) Can run on the same laptop as the CUCS or independently.

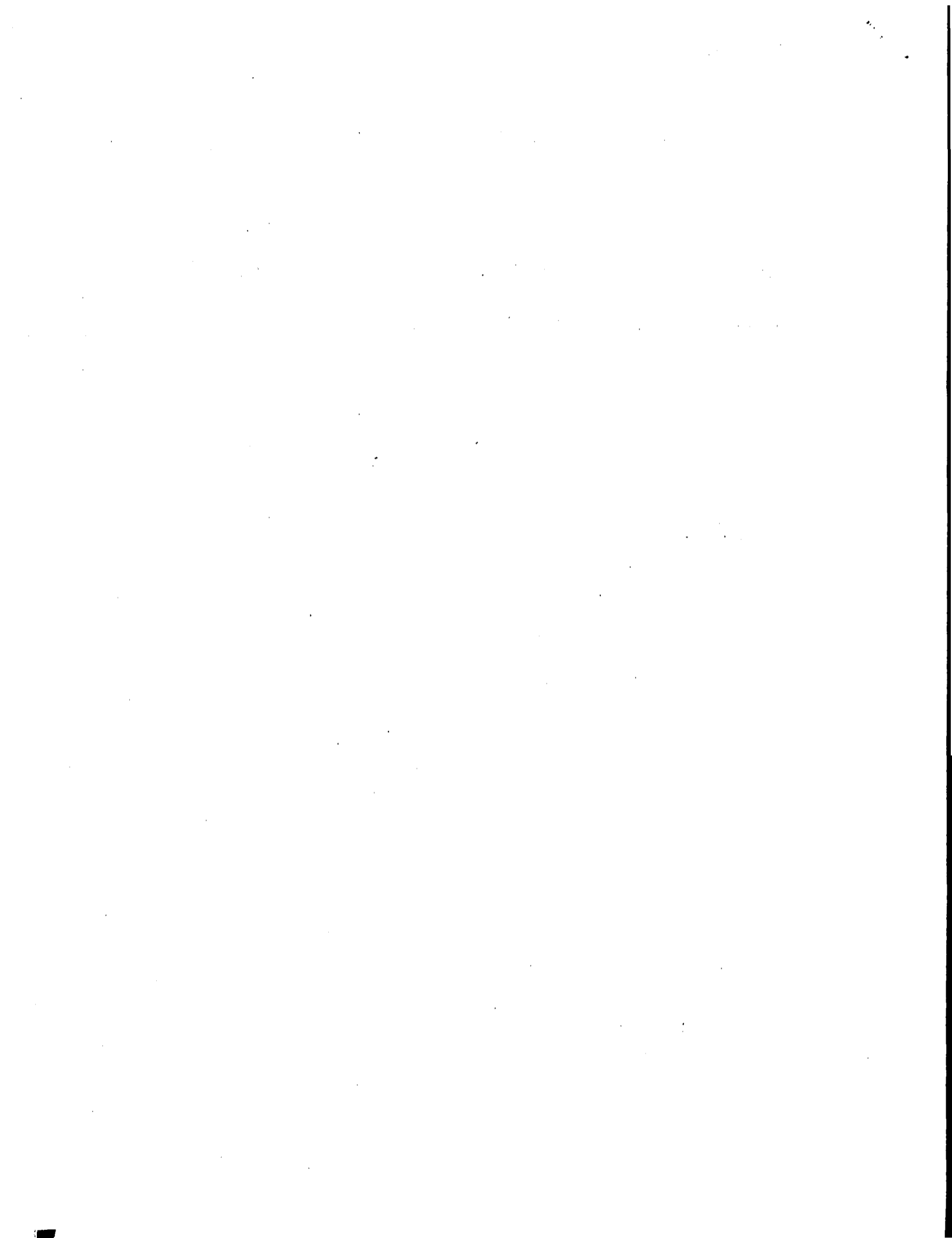

# Raytheon

(d) Can be hosted on the ground or in the aircraft.

(e) Laptop contains battery backup.

### 3 Ethernet Switch

(a) Gigabit ethernet switch provides communications pathway between elements.

### 4 MicroLight

(a) Raytheon produced software radio, used as a digital networked datalink.

(b) <http://www.raytheon.com/products/microlight/>

### 5 Firewall PC

(a) Laptop running firewall application to allow secure connection to Raytheon Intranet.

### 6 Net Modem

(a) Provides connection to VSat Commercial Satellite Link

### 7 VSat

(a) Provides commercial satellite connection to Raytheon Intranet.

(b) Can be used to disseminate UAS telemetry and sensor imagery.

(c) Can be used to receive weather, maps, mission plans and track data.

### 8 Video Digitizer

(a) Digitizes analog video signal to digital output for viewing and dissemination.

### 9 Video Receiver

(a) Receives analog video signal from the aircraft.

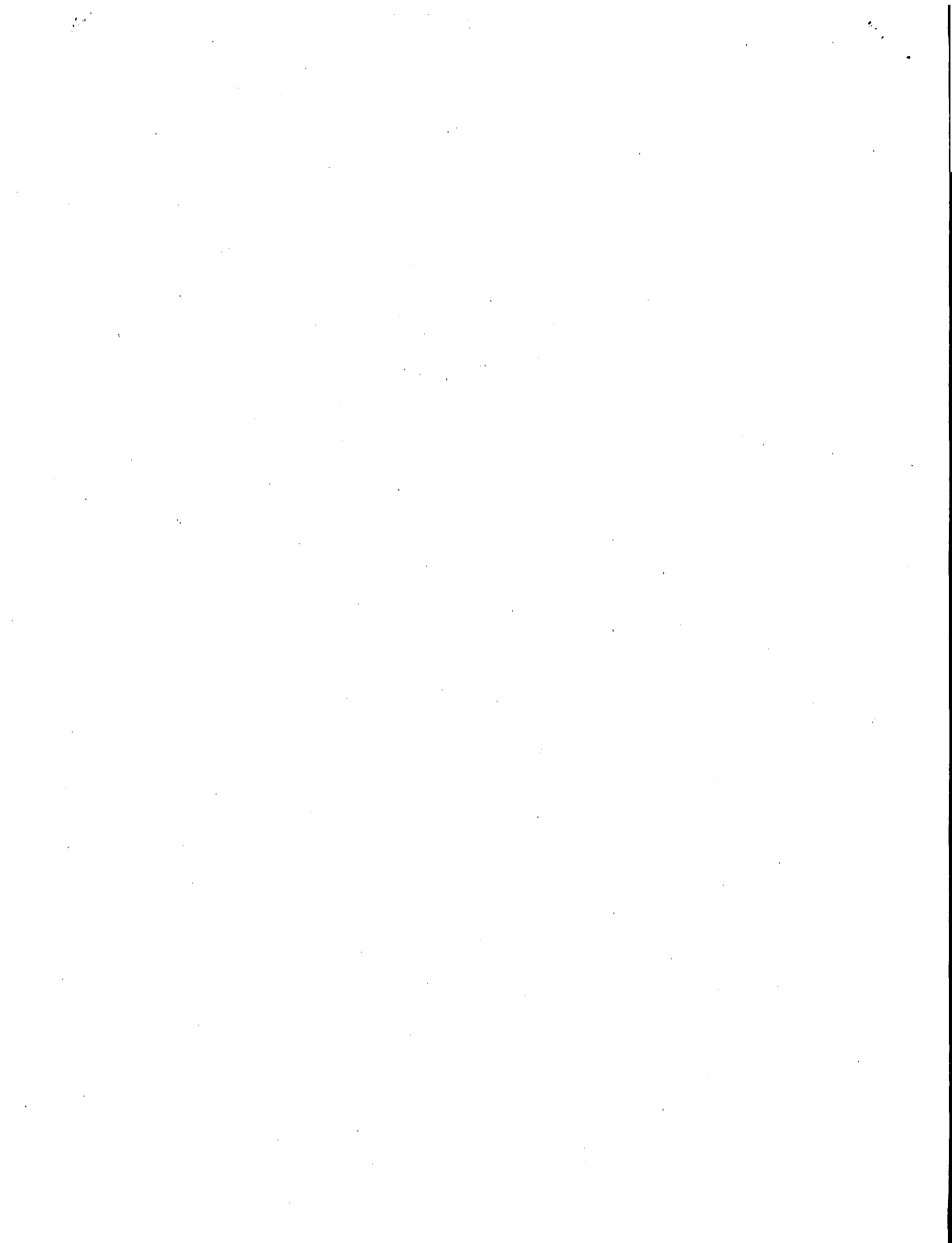

**Raytheon**

*Appendix G - FAA UAS Safety Checklist*

Separate Document

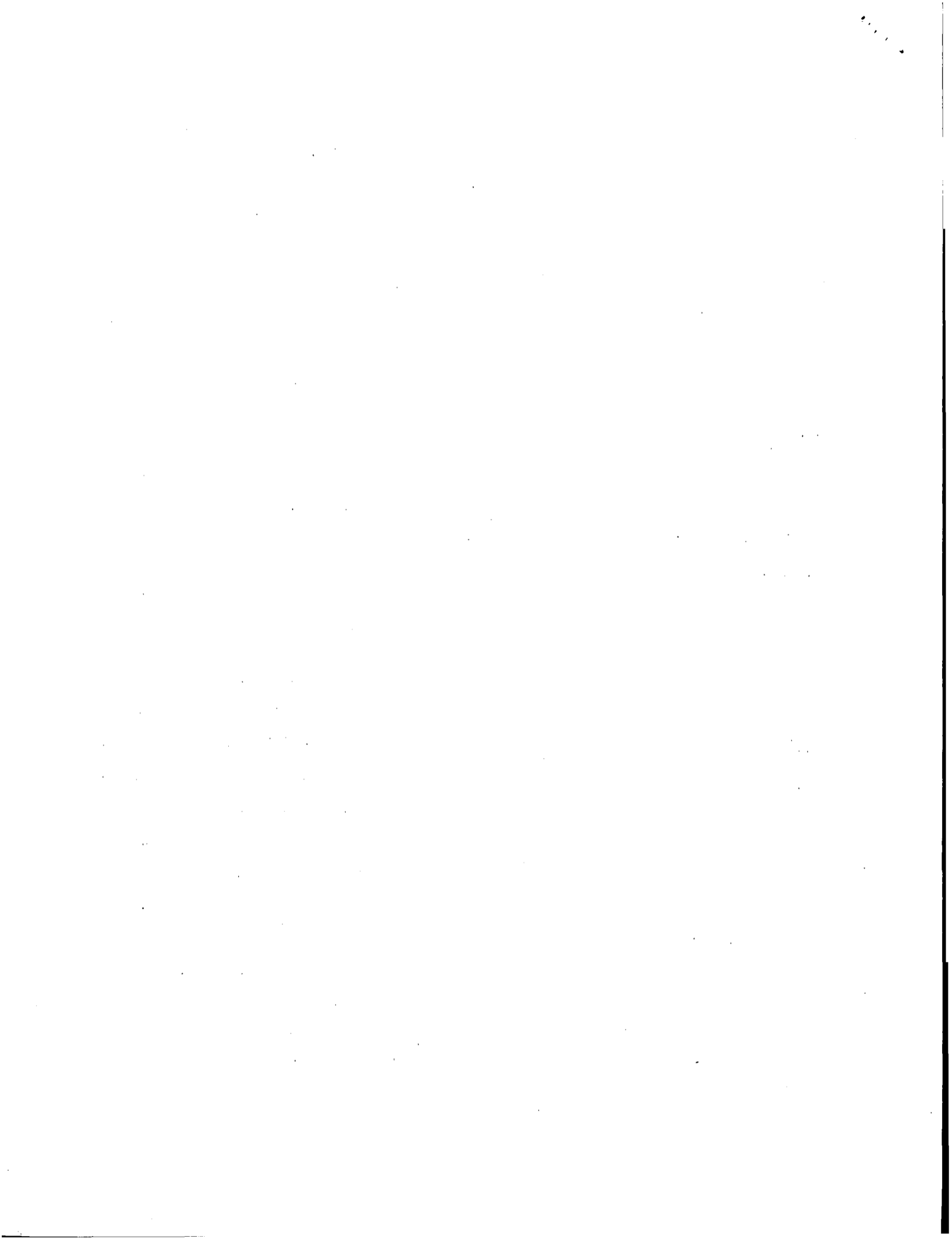

## Appendix H – Acronym List

<b>A</b>		<b>I</b>	
AGL		IFR	
Above Ground Level .....	4	Instrument Flight Rules .....	5
ATIS		IP	
Automatic Terminal Information Service .....	16	Internal Pilot .....	13
<b>C</b>		<b>J</b>	
CFR		JTRS	
Code of Federal Regulations .....	3	Joint Tactical Radio System .....	10
COTS			
Commercial Off-The-Shelf .....	9	<b>K</b>	
CUCS		KIAS	
Core UAV Control Station .....	10	Knots Indicated Airspeed .....	7
<b>D</b>		KTS	
DAFIF		Knots .....	7
Digital Aeronautical Information File .....	20	<b>L</b>	
DGPS		LUAV	
Differential Global Positioning System .....	9	Lethal Unmanned Aerial Vehicle .....	14
DoD			
Department of Defense .....	4	<b>M</b>	
DR		MAV	
Dead Reckoning .....	18	Micro Air Vehicle .....	14
<b>E</b>		MEL	
ECHUM		Minimum Equipment List .....	26
Electronic Chart Updating Manual .....	20	MEMS	
EMI		Micro-Electro-Mechanical Systems .....	8
Electro-Magnetic Interference .....	7	MFD	
EP		Multi-Function Display .....	10
External Pilot .....	5	MHX	
EPLRS		Multi-Plex .....	9
Enhanced Position Location Reporting System .....	10	MHz	
<b>F</b>		Mega-Hertz .....	10
FAA		MOA	
Federal Aviation Administration .....	4	Military Operating Area .....	5
FCC		MRA	
Federal Communications Commission .....	7	Minimum Reception Altitude .....	5
<b>G</b>		MSL	
GCS		Mean Sea Level .....	4
Ground Control Station .....	16	MVCS	
GHz		Multi-Vehicle Control System .....	11
Giga-Hertz .....	9	<b>N</b>	
GPS		NOTAM	
Global Positioning System .....	8	Notice to Airmen .....	4





## O

OI	Operator Interface.....	20
----	-------------------------	----

## P

PFD	Primary Flight Display.....	10
PFPS	DoD Portable Flight Planning System.....	20
PIC	Pilot in Command.....	13

## R

RC	Remote Control.....	13
RFI	Radio Frequency Interference.....	7
RX	Receive.....	31

## S

SE	Southeast.....	5
SP	Supplemental Pilot.....	13
STANAG	NATO Standardization Agreement.....	10
SUAV	Small Unmanned Aerial Vehicle.....	14
SW	Southwest.....	5

## T

TRR	Test Readiness Review.....	12
TX	Transmit.....	31

## U

UA	Unmanned Aircraft.....	<i>Unmanned Aircraft System</i>
UAS	Unmanned Aircraft System.....	2
UAV	Unmanned Aerial Vehicle.....	10
UHF	Ultra High Frequency.....	9
UPS	Uninterruptible Power Supply.....	30
UVI	Unmanned Vehicles International.....	3

## V

VFR	Visual Flight Rules.....	7
VHF	Very High Frequency.....	20
VMC	Visual Meteorological Conditions.....	7
VR	Military VFR Training Route.....	5
VSM	Vehicle Specific Module.....	10

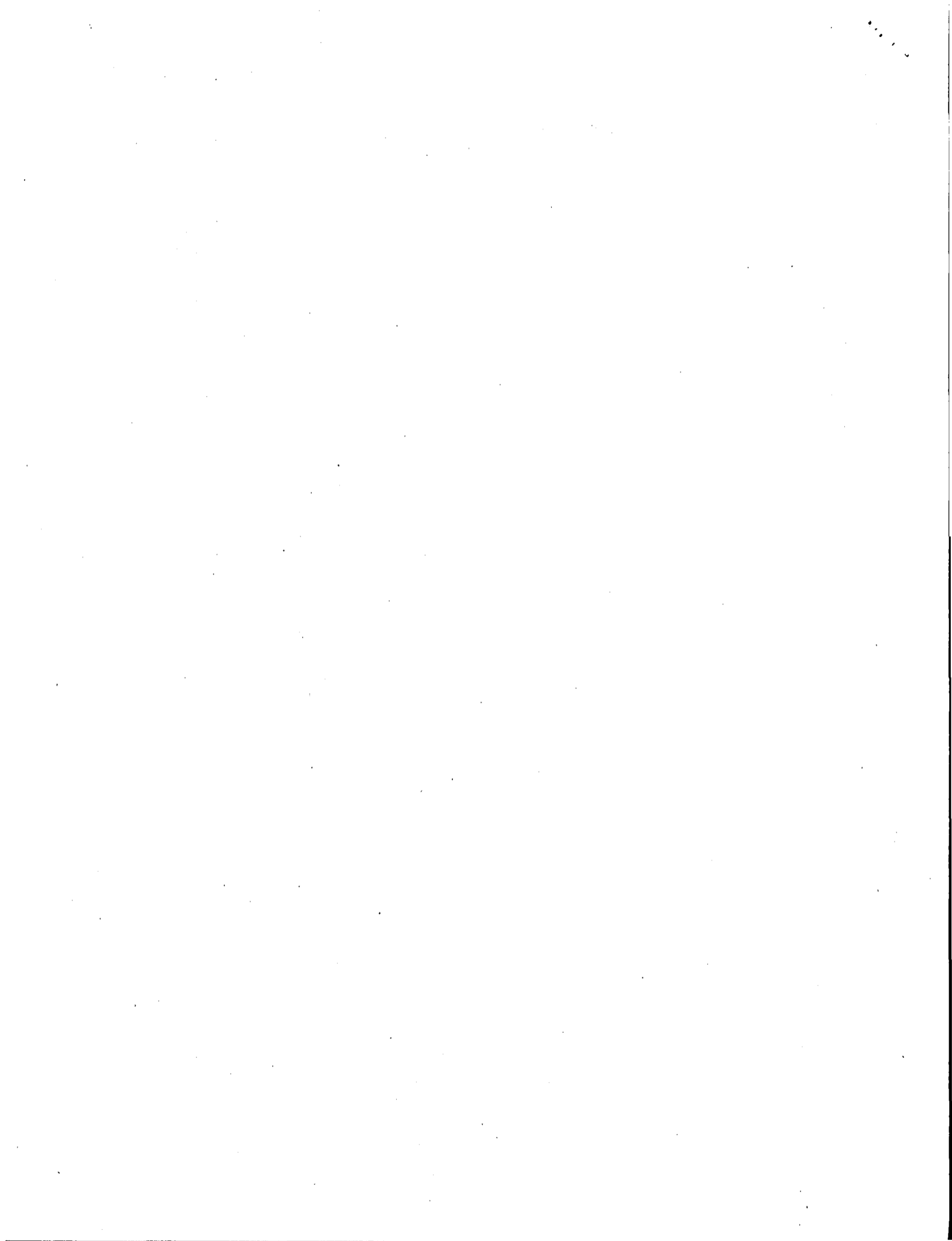

**Raytheon**



FAA FORM 8130-6, APPLICATION FOR U.S. AIRWORTHINESS CERTIFICATE

Form Approved O.M.B. No. 2120-0018  
12/31/2010

Accepted RJ Jan/18/2011

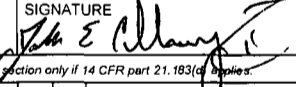
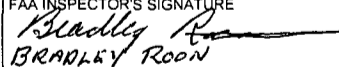
 U.S. Department of Transportation Federal Aviation Administration		APPLICATION FOR U.S. AIRWORTHINESS CERTIFICATE		INSTRUCTIONS - Print or type. Do not write in shaded areas; these are for FAA use only. Submit original only to an authorized FAA Representative. If additional space is required, use attachment. For special flight permits complete Sections II, VI and VII as applicable.			
I. AIRCRAFT DESIGNATION	1. REGISTRATION MARK	2. AIRCRAFT BUILDER'S NAME (Make)	3. AIRCRAFT MODEL DESIGNATION	4. YR. MFR.	FAA CODING		
	N606RN	RAYTHEON	COBRA	2006			
	5. AIRCRAFT SERIAL NO.	6. ENGINE BUILDER'S NAME (Make)	7. ENGINE MODEL DESIGNATION				
006	DESERT AIRCRAFT	DA-150					
8. NUMBER OF ENGINES	9. PROPELLER BUILDER'S NAME (Make)	10. PROPELLER MODEL DESIGNATION			11. AIRCRAFT IS (Check if applicable)		
1	MEZLICK	28 X 12-3B			IMPORT		
APPLICATION IS HEREBY MADE FOR: (Check applicable items)							
A	1	STANDARD AIRWORTHINESS CERTIFICATE (Indicate Category)		NORMAL	UTILITY	ACROBATIC	
B	✓	SPECIAL AIRWORTHINESS CERTIFICATE (Check appropriate items)		UNMANNED AIRCRAFT			
II. CERTIFICATION REQUESTED	7	PRIMARY					
	9	LIGHT-SPORT (Indicate Class)	AIRPLANE	POWER-PARACHUTE	WEIGHT-SHIFT-CONTROL	GLIDER	
	2	LIMITED					
	5	PROVISIONAL (Indicate Class)	1	CLASS I			
			2	CLASS II			
	3	RESTRICTED (Indicate operation(s) to be conducted)	1	AGRICULTURE AND PEST CONTROL	2	AERIAL SURVEY	3
			4	FOREST (Wildlife Conservation)	5	PATROLLING	6
			0	OTHER (Specify)			
	4	✓ EXPERIMENTAL (Indicate operation(s) to be conducted)	1	✓ RESEARCH AND DEVELOPMENT	2	AMATEUR BUILT	3
			4	AIR RACING	5	✓ CREW TRAINING	6
0			TO SHOW COMPLIANCE WITH THE CFR				
7			OPERATING (Primary Category) KIT BUILT AIRCRAFT				
8	SPECIAL FLIGHT PERMIT (Indicate operation(s) to be conducted, then complete Section VI or VII as applicable on reverse side)	1	✓ FERRY FLIGHT FOR REPAIRS, ALTERATIONS, MAINTENANCE, OR STORAGE				
		2	EVACUATION FROM AREA OF IMPENDING DANGER				
		3	OPERATION IN EXCESS OF MAXIMUM CERTIFICATED TAKE-OFF WEIGHT				
		4	DELIVERING OR EXPORTING	5	PRODUCTION FLIGHT TESTING		
6	CUSTOMER DEMONSTRATION FLIGHTS						
C	6	MULTIPLE AIRWORTHINESS CERTIFICATE (check ABOVE "Restricted Operation" and "Standard" or "Limited" as applicable)					
III. OWNER'S CERTIFICATION	A. REGISTERED OWNER (As shown on certificate of aircraft registration)		IF DEALER, CHECK HERE →				
	NAME RAYTHEON COMPANY		ADDRESS PO BOX 11337, TUCSON, AZ 85734-1337				
	B. AIRCRAFT CERTIFICATION BASIS (Check applicable blocks and complete items as indicated)						
	AIRCRAFT SPECIFICATION OR TYPE CERTIFICATE DATA SHEET (Give No. and Revision No.) N/A		AIRCRAFT LISTING (Give page number(s)) N/A				
	AIRCRAFT LISTING (Give page number(s)) N/A		AIRWORTHINESS DIRECTIVES (Check if all applicable AD's are compiled with and give the number of the last AD SUPPLEMENT available in the biweekly series as of the date of application) AD BI-WEEKLY 2010-25				
C. AIRCRAFT OPERATION AND MAINTENANCE RECORDS							
✓	CHECK IF RECORDS IN COMPLIANCE WITH 14 CFR Section 91.417	TOTAL AIRFRAME HOURS	6.1	EXPERIMENTAL ONLY (Enter hours flown since last certificate issued or renewed)	6.0	3	
D. CERTIFICATION - I hereby certify that I am the registered owner (or his agent) of the aircraft described above, that the aircraft is registered with the Federal Aviation Administration in accordance with Title 49 of the United States Code 44101 et seq. and applicable Federal Aviation Regulations, and that the aircraft has been inspected and is airworthy and eligible for the airworthiness certificate requested.							
DATE OF APPLICATION 14 DECEMBER 2010		NAME AND TITLE (Print or type) John E. Calloway, Flight test Operations Manager		SIGNATURE 			
IV. INSPECTION AGENCY VERIFICATION	A. THE AIRCRAFT DESCRIBED ABOVE HAS BEEN INSPECTED AND FOUND AIRWORTHY BY: (Complete this section only if 14 CFR part 21.183(a) applies.)						
	2	14 CFR part 121 CERTIFICATE HOLDER (Give Certificate No.)	3	CERTIFICATED MECHANIC (Give Certificate No.)	6	CERTIFICATED REPAIR STATION (Give Certificate No.)	
	5	AIRCRAFT MANUFACTURER (Give name or firm)					
DATE		TITLE		SIGNATURE			
V. FAA REPRESENTATIVE CERTIFICATION	(Check ALL applicable block items A and B)						
	A. I find that the aircraft described in Section I or VII meets requirements for			4			
	B. Inspection for a special permit under Section VII was conducted by:			THE CERTIFICATE REQUESTED			
	DESIGNEE'S SIGNATURE AND NO.			AMENDMENT OR MODIFICATION OF CURRENT AIRWORTHINESS CERTIFICATE			
DATE	MIDO/FSDO Office	DESIGNEE'S SIGNATURE AND NO.	FAA INSPECTOR	FAA DESIGNEE			
12/14/2010	PHOENIX M100 DM-50	4					
			1	FAA INSPECTOR'S SIGNATURE  BRADLEY ROON			

<b>VI. PRODUCTION FLIGHT TESTING</b>	A. MANUFACTURER			
	NAME		ADDRESS	
	B. PRODUCTION BASIS <i>(Check applicable item)</i>			
	<input type="checkbox"/> PRODUCTION CERTIFICATE <i>(Give production certificate number)</i> →		<input type="checkbox"/> TYPE CERTIFICATE ONLY	
	<input type="checkbox"/> APPROVED PRODUCTION INSPECTION SYSTEM			
	C. GIVE QUANTITY OF CERTIFICATES REQUIRED FOR OPERATING NEEDS			
DATE OF APPLICATION		NAME AND TITLE <i>(Print or Type)</i>	SIGNATURE	
<b>VII. SPECIAL FLIGHT PERMIT PURPOSES OTHER THAN PRODUCTION FLIGHT TEST</b>	A. DESCRIPTION OF AIRCRAFT			
	REGISTERED OWNER		ADDRESS	
	BUILDER <i>(Make)</i>		MODEL	
	SERIAL NUMBER		REGISTRATION MARK	
	B. DESCRIPTION OF FLIGHT			
	FROM		TO	<input type="checkbox"/> CUSTOMER DEMONSTRATION FLIGHTS <i>(Check if applicable)</i>
	VIA		DEPARTURE DATE	DURATION
	C. CREW REQUIRED TO OPERATE THE AIRCRAFT AND ITS EQUIPMENT			
	<input type="checkbox"/> PILOT	<input type="checkbox"/> CO-PILOT	<input type="checkbox"/> FLIGHT ENGINEER	<input type="checkbox"/> OTHER <i>(Specify)</i>
	D. THE AIRCRAFT DOES NOT MEET THE APPLICABLE AIRWORTHINESS REQUIREMENTS AS FOLLOWS:			
	E. THE FOLLOWING RESTRICTIONS ARE CONSIDERED NECESSARY FOR SAFE OPERATION: <i>(Use attachment if necessary)</i>			
F. CERTIFICATION - I hereby certify that I am the registered owner (or his agent) of the aircraft described above; that the aircraft is registered with the Federal Aviation Administration in accordance with Title 49 of the United States Code 44101 et seq. and applicable Federal Aviation Regulations; and that the aircraft has been inspected and is safe for the flight described.				
DATE		NAME AND TITLE <i>(Print or Type)</i>	SIGNATURE	
<b>VIII. AIRWORTHINESS DOCUMENTATION (FAA DESIGNEE use only)</b>	<input checked="" type="checkbox"/> A. Operating Limitations and Markings in Compliance with 14 CFR Section 91.9, as applicable.	<input type="checkbox"/> G. Statement of Conformity, FAA Form 8130-9 <i>(Attach when required)</i>		
	<input checked="" type="checkbox"/> B. Current Operating Limitations Attached	<input type="checkbox"/> H. Foreign Airworthiness Certification for Import Aircraft <i>(Attach when required)</i>		
	<input checked="" type="checkbox"/> C. Data, Drawings, Photographs, etc. <i>(Attach when required)</i>	<input checked="" type="checkbox"/> I. Previous Airworthiness Certificate Issued in Accordance with 14 CFR Section <u>21.191(b)(c)(f)</u> CAR _____ <i>(Original Attached)</i>		
	<input checked="" type="checkbox"/> D. Current Weight and Balance information Available in Aircraft	<input checked="" type="checkbox"/> J. Current Airworthiness Certificate Issued in Accordance with 14 CFR Section <u>21.191(b)(c)(f)</u> <i>(Copy Attached)</i>		
	<input type="checkbox"/> E. Major Repair and Alteration, FAA Form 337 <i>(Attach when required)</i>	<input type="checkbox"/> K. Light-Sport Aircraft Statement of Compliance, FAA Form 8130-15 <i>(Attach when required)</i>		
	<input checked="" type="checkbox"/> F. This inspection Recorded in Aircraft Records			

UNITED STATES OF AMERICA  
DEPARTMENT OF TRANSPORTATION - FEDERAL AVIATION ADMINISTRATION  
**SPECIAL AIRWORTHINESS CERTIFICATE**

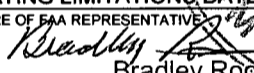
<b>A</b>	CATEGORY/DESIGNATION	Experimental (Unmanned Aircraft)		
	PURPOSE	Research and Development, Crew Training, and/or Market Survey		
<b>B</b>	MANUFACTURER	NAME	N/A	
		ADDRESS	N/A	
<b>C</b>	FLIGHT	FROM	N/A	
		TO	N/A	
<b>D</b>	N- 606RN	SERIAL NO.	006	
	BUILDER	Raytheon Company	MODEL	Cobra
<b>E</b>	DATE OF ISSUANCE	December 14, 2010	EXPIRY	December 14, 2011
	OPERATING LIMITATIONS DATED	12/14/10	(ARE PART OF THIS CERTIFICATE)	
SIGNATURE OF FAA REPRESENTATIVE		DESIGNATION OR OFFICE NO.		
 Bradley Rood		Phoenix MIDO NM-50		

Any alteration, reproduction or misuse of this certificate may be punishable by a fine not exceeding \$1,000 or imprisonment not exceeding 3 years, or both. THIS CERTIFICATE MUST BE DISPLAYED IN THE AIRCRAFT IN ACCORDANCE WITH APPLICABLE TITLE 14, CODE OF FEDERAL REGULATIONS (CFR).

FAA Form 8130-7 (07/04) SEE REVERSE SIDE NSN: 0052-00-693-4000

<b>A</b>	This airworthiness certificate is issued under the authority of Public Law 104-6, 49 United States Code (USC) 44704 and Title 14 Code of Federal Regulations (CFR).
<b>B</b>	The airworthiness certificate authorizes the manufacturer named on the reverse side to conduct production flight tests, and only production flight tests, of aircraft registered in his name. No person may conduct production flight tests under this certificate: (1) Carrying persons or property for compensation or hire; and/or (2) Carrying persons not essential to the purpose of the flight.
<b>C</b>	This airworthiness certificate authorizes the flight specified on the reverse side for the purpose shown in Block A.
<b>D</b>	This airworthiness certificate certifies that as of the date of issuance, the aircraft to which issued has been inspected and found to meet the requirements of the applicable CFR. The aircraft does not meet the requirements of the applicable comprehensive and detailed airworthiness code as provided by Annex 8 to the Convention On International Civil Aviation. No person may operate the aircraft described on the reverse side: (1) except in accordance with the applicable CFR and in accordance with conditions and limitations which may be prescribed by the Administrator as part of this certificate; (2) over any foreign country without the special permission of that country.
<b>E</b>	Unless sooner surrendered, suspended, or revoked, this airworthiness certificate is effective for the duration and under the conditions prescribed in 14 CFR, Part 21, Section 21.181 or 21.217.



UNITED STATES OF AMERICA  
 DEPARTMENT OF TRANSPORTATION - FEDERAL AVIATION ADMINISTRATION  
**SPECIAL AIRWORTHINESS CERTIFICATE**

<b>A</b>	CATEGORY/DESIGNATION <u>Experimental (Unmanned Aircraft)</u>	
	PURPOSE <u>Research and Development, Crew Training, and/or Market Survey</u>	
<b>B</b>	MANUFACTURER	NAME <u>N/A</u>
		ADDRESS <u>N/A</u>
<b>C</b>	FLIGHT	FROM <u>N/A</u>
		TO <u>N/A</u>
<b>D</b>	N- <u>606RN</u>	SERIAL NO. <u>006</u>
	BUILDER <u>Raytheon Company</u>	MODEL <u>Cobra</u>
<b>E</b>	DATE OF ISSUANCE <u>October 28, 2009</u>	EXPIRY <u>October 28, 2010</u>
	OPERATING LIMITATIONS DATED <u>10/28/09</u>	(ARE PART OF THIS CERTIFICATE)
<b>E</b>	SIGNATURE OF FAA REPRESENTATIVE <i>Cindy Napolitano</i> Cindy Napolitano	DESIGNATION OR OFFICE NO. Phoenix MIDO NM-50

Any alteration, reproduction or misuse of this certificate may be punishable by a fine not exceeding \$1,000 or imprisonment not exceeding 3 years, or both. THIS CERTIFICATE MUST BE DISPLAYED IN THE AIRCRAFT IN ACCORDANCE WITH APPLICABLE TITLE 14, CODE OF FEDERAL REGULATIONS (CFR).

<b>A</b>	This airworthiness certificate is issued under the authority of Public Law 104-6, 49 United States Code (USC) 44704 and Title 14 Code of Federal Regulations (CFR).
<b>B</b>	The airworthiness certificate authorizes the manufacturer named on the reverse side to conduct production flight tests, and only production flight tests, of aircraft registered in his name. No person may conduct production flight tests under this certificate: (1) Carrying persons or property for compensation or hire; and/or (2) Carrying persons not essential to the purpose of the flight.
<b>C</b>	This airworthiness certificate authorizes the flight specified on the reverse side for the purpose shown in Block A.
<b>D</b>	This airworthiness certificate certifies that as of the date of issuance, the aircraft to which issued has been inspected and found to meet the requirements of the applicable CFR. The aircraft does not meet the requirements of the applicable comprehensive and detailed airworthiness code as provided by Annex 8 to the Convention On International Civil Aviation. No person may operate the aircraft described on the reverse side: (1) except in accordance with the applicable CFR and in accordance with conditions and limitations which may be prescribed by the Administrator as part of this certificate; (2) over any foreign country without the special permission of that country.
<b>E</b>	Unless sooner surrendered, suspended, or revoked, this airworthiness certificate is effective for the duration and under the conditions prescribed in 14 CFR, Part 21, Section 21.181 or 21.217.

December 14, 2010



Phoenix Manufacturing Inspection District Office  
17777 North Perimeter Drive, Suite 103  
Scottsdale, Arizona 85255

**Operating Limitations**  
**Experimental: Research and Development, Market Survey,**  
**and/or Crew Training**

<b>Registered Owner Name:</b> Raytheon Missile Systems	<b>Aircraft Builder:</b> Raytheon Missile Systems
<b>Registered Owner Address:</b> Bldg M09, M/S 5 P.O. Box 11337 Tucson, AZ 85734-1337	Bldg M09, M/S 5 P.O. Box 11337 Tucson, AZ 85734-1337
<b>Aircraft Description:</b> Unmanned, composite, mid-wing monoplane with standard tail surfaces and a tractor engine.	<b>Year Manufactured:</b> 2006
<b>Aircraft Registration:</b> N606RN	<b>Aircraft Serial Number:</b> 006
	<b>Aircraft Model Designation:</b> Cobra
	<b>Engine Model:</b> Desert Aircraft DA-150

**The following conditions and limitations apply to all unmanned aircraft system (UAS) flight operations for the Raytheon Cobra while operating in the National Airspace System (NAS).**

**1. General Information.**

**a. Integrated system.** For the purposes of this special airworthiness certificate and operating limitations, the Raytheon Cobra operated by Raytheon Missile Systems is considered to be an integrated system. The system is composed of the following:

- (1) Raytheon Missile Systems, Cobra, unmanned aircraft, s/n 006,
- (2) UAS control stations, fixed, mobile, or ground-based,
- (3) Telemetry, launch, and recovery equipment,
- (4) Communications and navigation equipment, including ground and/or airborne equipment used for command and control of the Raytheon Cobra.
- (5) Equipment on the ground and in the air used for communication with other members of the flightcrew, observers, air traffic control (ATC), and other users of the NAS.

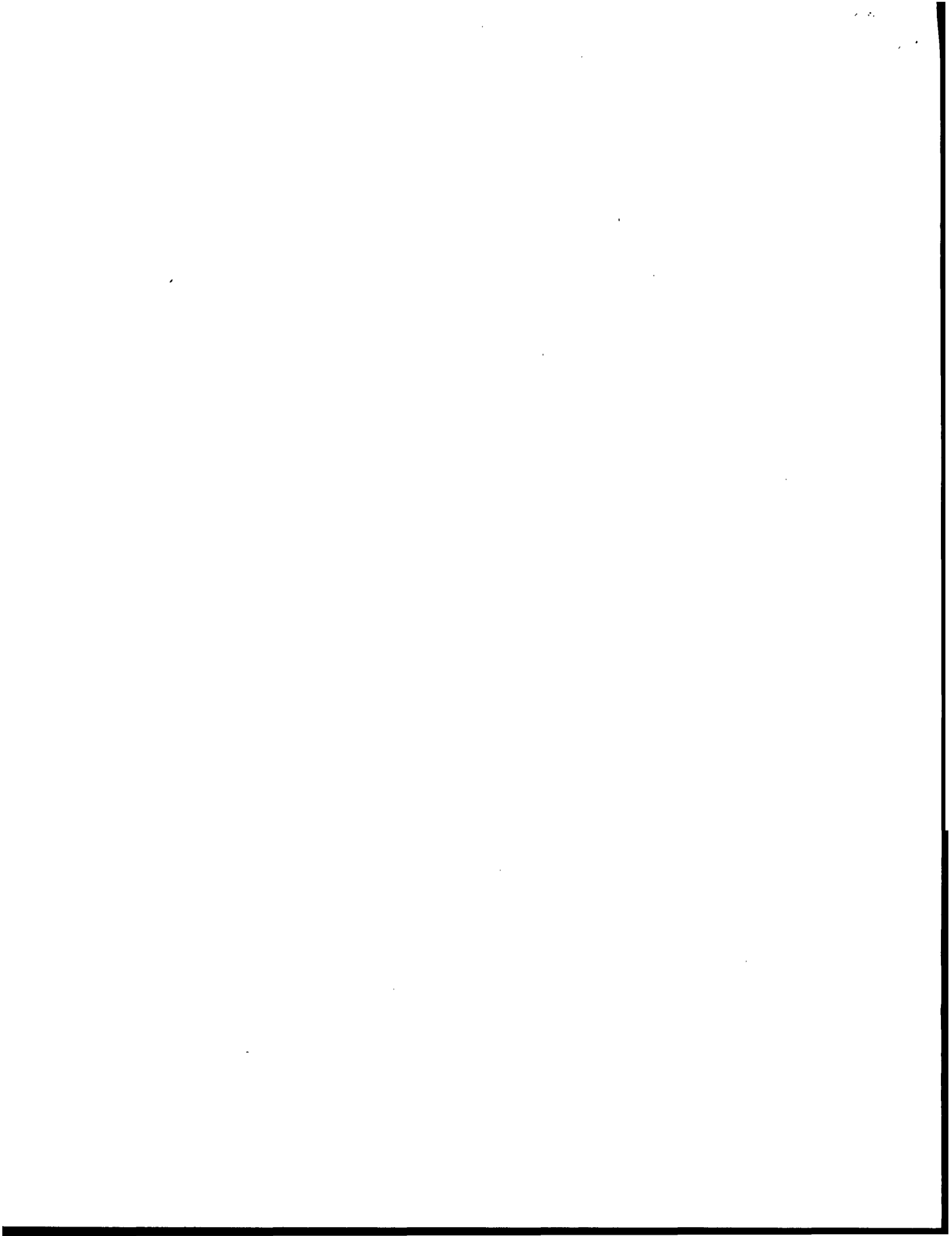

December 14, 2010

**b. Compliance with 14 CFR Part 61 (Certification: Pilots, Flight Instructors, and Ground Instructors) and part 91 (General Operating and Flight Rules).** Unless otherwise specified in this document, the UA pilot-in-command (PIC) and Raytheon Missile Systems must comply with all applicable sections and parts of 14 CFR including, but not limited to, parts 61 and 91.

**c. Operational requirements.**

(1) No person may operate this UAS for other than the purpose of research and development, market survey, and/or crew training, to accomplish the flight operation outlined in Raytheon Missile Systems program letter dated 09/20/2010, which describes compliance with § 21.193(d), Experimental certificates: General, and has been made available to the UA PIC.

(2) This UAS must be operated in accordance with applicable air traffic and general operating rules of part 91 and all additional limitations herein prescribed under the provisions of § 91.319(i), Aircraft having experimental certificates: Operating limitations.

(3) Raytheon Missile Systems must accumulate at least 50 flight hours under its experimental airworthiness certificate before customer crew training is permitted, in accordance with § 21.195(d), Experimental certificates: Aircraft to be used for market surveys, sales demonstrations, and customer crew training.

**d. UA condition.** The UA PIC must determine that the UA is in a condition for safe operation and in a configuration appropriate for the purpose of the intended flight.

**e. Multiple-purpose operations.** When changing between operating purposes of a multiple purpose certificate, the operator must determine that the aircraft is in a condition for safe operation and appropriate for the purpose intended. A record entry will be made by an appropriately rated person (that is, an individual authorized by the applicant and acceptable to the FAA) to document that finding in the aircraft maintenance records.

**f. Operation exceptions.** No person may operate this UA to carry property for compensation or hire (§ 91.319(a)(2)).

**g. UA markings.**

(1) This UA must be marked with its U.S. registration number in accordance with part 45 or alternative marking approval issued by the FAA Production and Airworthiness Division (AIR-200).

(2) This UA must display the word *Experimental* in accordance with § 45.23(b), Display of marks, unless otherwise granted an exemption from this requirement.

**h. Required documentation.** Before conducting the initial flight of the Cobra UAS, Raytheon Missile Systems must transmit by email a scanned copy of the Raytheon Cobra program letter, special airworthiness certificate, and operating limitations to the following FAA personnel:

(1) Debra Trindle, FAA Air Traffic Representative, Luke and Davis-Monthan Air Force Base, AZ, (623) 856-9596, email: [debra.trindle@faa.gov](mailto:debra.trindle@faa.gov).

(2) Roger Trevino, System Support Specialist, FAA Central Service Area, System Support Group, AJO2-C2, (817)-222-5595, email: [roger.trevino@faa.gov](mailto:roger.trevino@faa.gov)

(3) Richard Posey, Aviation Safety Inspector, Production and Airworthiness Division, AIR-200, (202) 267-9538, email: [richard.posey@faa.gov](mailto:richard.posey@faa.gov).



December 14, 2010

**i. Change in registrant address.** Section 47.45, Change of address, requires that the FAA Aircraft Registry be notified within 30 days of any change in the aircraft registrant's address. Such notification is to be made by providing AC Form 8050-1, Aircraft Registration Application, to the FAA Aircraft Registration Branch (AFS-750) in Oklahoma City, Oklahoma.

**j. Certificate display and manual availability.** The airworthiness and registration certificates must be displayed, and the aircraft flight manual must be available to the pilot, as prescribed by the applicable sections of 14 CFR, or as prescribed by an exemption granted to Raytheon Missile Systems, in accordance with 14 CFR part 11, General Rulemaking Procedures.

**2. Program Letter.** The Raytheon Cobra program letter, dated 09/20/2010, will be used as a basis for determining the operating limitations prescribed in this document. All flight operations must be conducted in accordance with the provisions of this document.

### **3. Initial Flight Testing.**

**a. Requirements.** Flight operations must be conducted within visual line of sight of the pilot/observer. Initial flight testing must be completed upon accumulation of 25 flight hours. Following satisfactory completion of initial flight testing, the operations manager or chief pilot must certify in the records that the aircraft has been shown to comply with § 91.319(b). Compliance with § 91.319(b) must be recorded in the aircraft records with the following, or a similarly worded, statement:

*I certify that the prescribed flight test hours have been completed and the aircraft is controllable throughout its normal range of speeds and throughout all maneuvers to be executed, has no hazardous operating characteristics or design features, and is safe for operation. The following aircraft operating data has been demonstrated during the flight testing: speeds Vx \_\_\_\_\_, and Vy \_\_\_\_\_, and the weight \_\_\_\_\_ and CG location \_\_\_\_\_ at which they were obtained.*

**b. Aircraft operations for the purpose of market surveys, sales demonstrations, and customer crew training.** These operations cannot be performed until 50 flight hours have been accomplished. An entry in the aircraft maintenance records is required as evidence of compliance.

### **4. Authorized Flight Operations Area.**

**a.** The main base of operations for the UA shall be:

Unmanned Vehicles International, Inc  
2595 North Sagebrush Road, Whetstone, AZ  
±4 Miles east of State Route 90 on State Route 82, west of  
Mile Post 56, ½ mile north. on Sagebrush Road  
T20S, R20E, Sec. 3

This is the address of the Cochise County Western Region Landfill. UVI is accessed through the landfill property.

**b.** The flight operations area authorized for the UA is depicted graphically below. This area shall be referred to as the Primary Containment Area (PCA). It is recognized that Raytheon may be permitted to operate within Special Use Airspace (SUA) per authorization

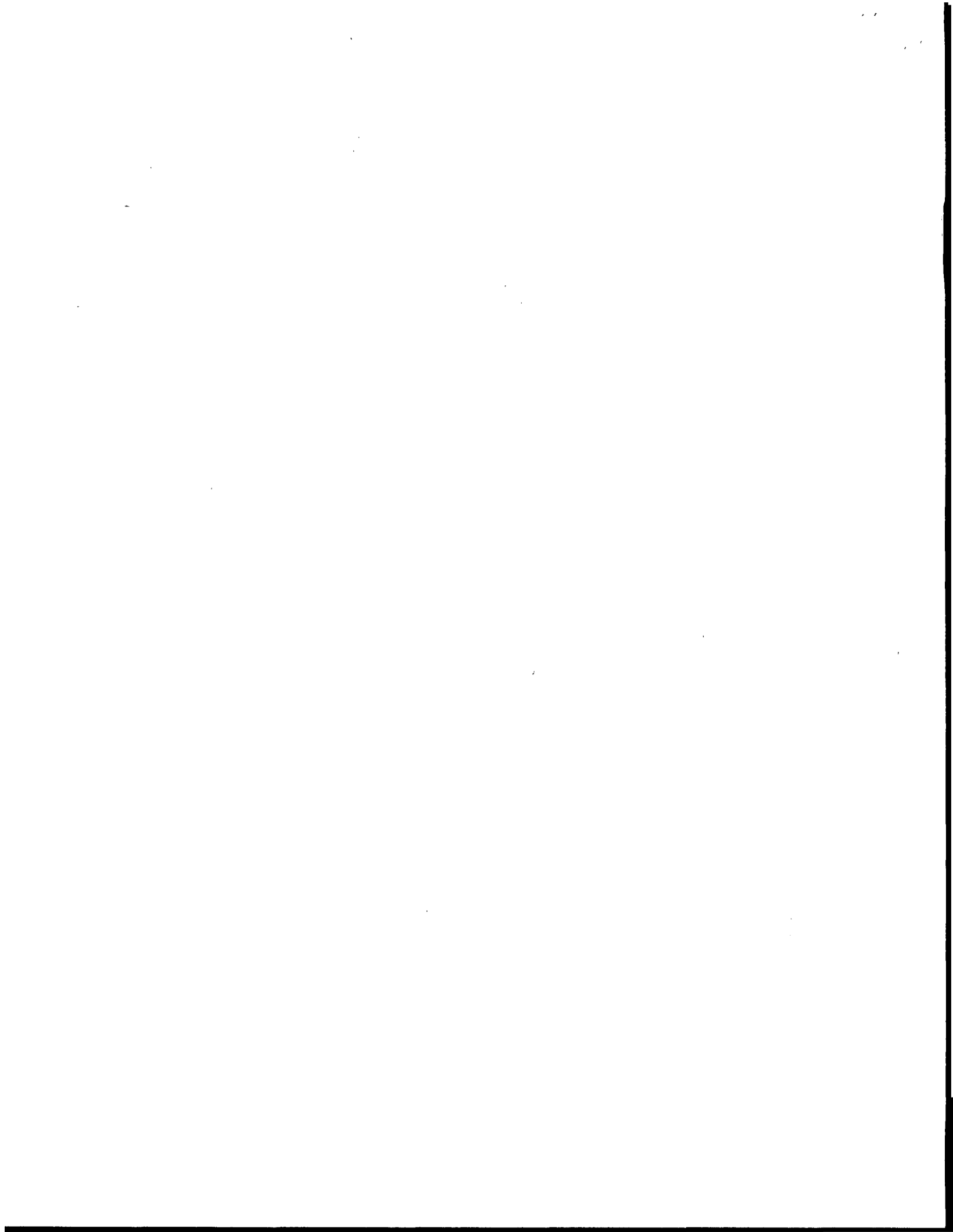



December 14, 2010

of the using agency. Under these circumstances, should the UA venture beyond the boundaries of the SUA (e.g. spill out), provisions of this experimental certificate shall apply, including authorization to only operate within the boundaries of the PCA. In these circumstances, Raytheon is responsible for notifying the FAA of the breach of any operations area.

c. The boundary of the Primary Containment Area is defined by the following coordinates:

- (1) N 31° 44' 00.00" W 110° 20' 30.00"
- (2) N 31° 52' 00.00" W 110° 20' 00.00"
- (3) N 31° 52' 00.00" W 110° 11' 00.00"
- (4) N 31° 56' 30.00" W 110° 11' 00.00"
- (5) N 31° 58' 10.00" W 110° 03' 00.00"
- (6) N 31° 50' 30.00" W 110° 03' 00.00"
- (7) N 31° 50' 30.00" W 110° 00' 00.00"
- (8) N 31° 45' 00.00" W 110° 00' 00.00"
- (9) N 31° 45' 00.00" W 110° 11' 00.00"
- (10) N 31° 43' 14.00" W 110° 14' 00.00"
- (11) N 31° 42' 00.00" W 110° 19' 30.00"
- (12) N 31° 44' 00.00" W 110° 19' 30.00"
- (13) Return to 1

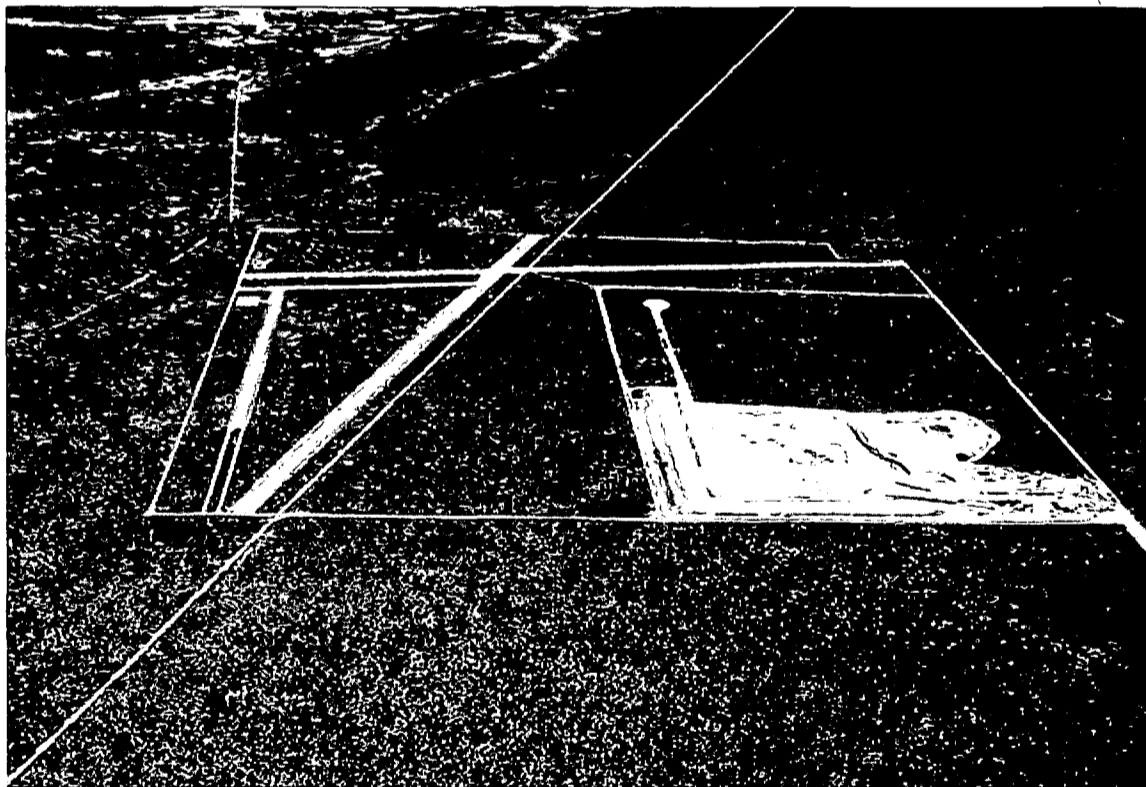

Figure 1. UVI UAS airfield looking north, located next to the Cochise County landfill.

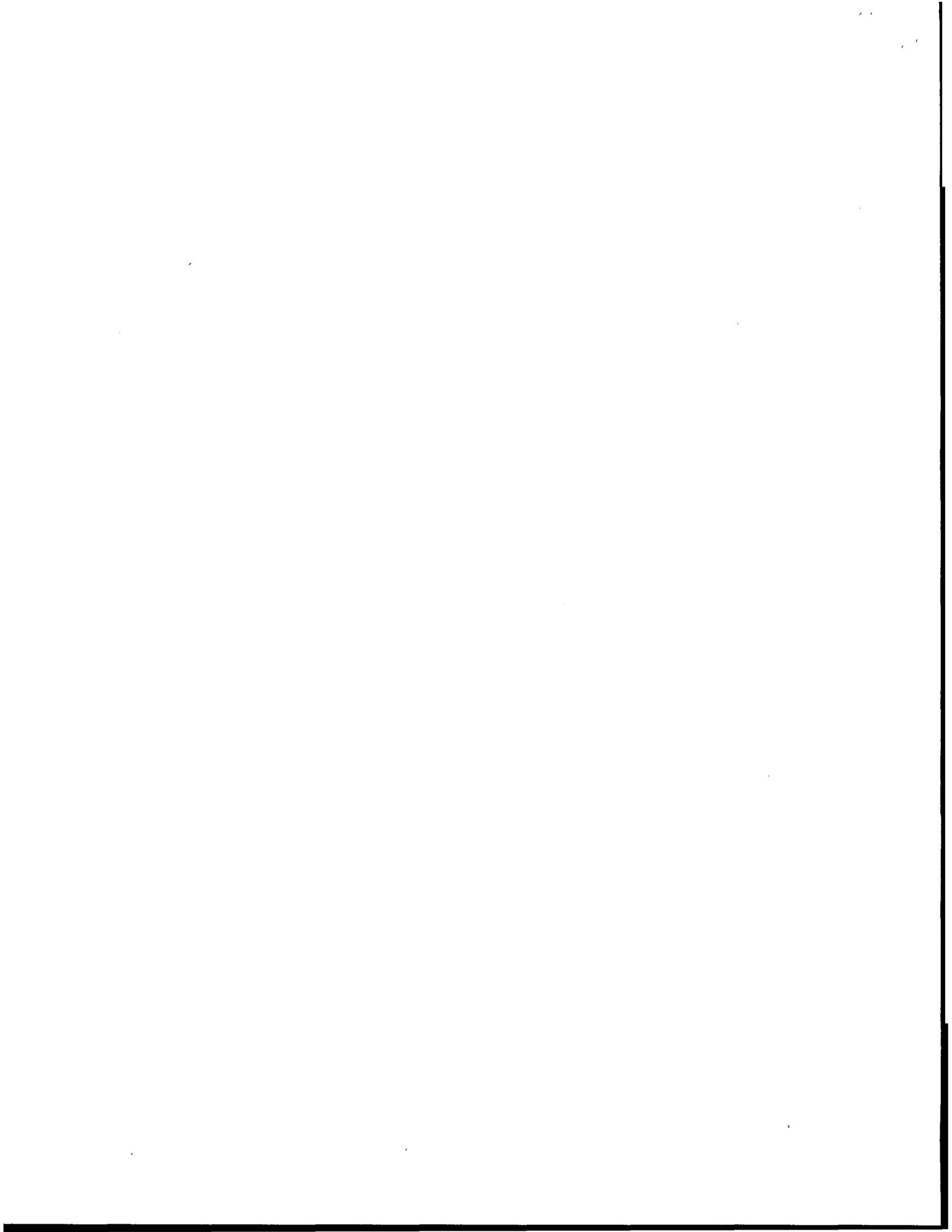



Figure 2. Phoenix Sectional, FHU 004/08.5, 4225' Elevation, N 31° 43' 30", W 110° 17' 47".

**d. Criteria for remaining in the flight test area.** The UAS PIC must ensure all UA flight operations remain within the lateral and vertical boundaries of the flight test area. **The maximum ceiling for all flight operations is 2000 ft AGL.** The UAS PIC must take into account all factors that may affect the capability of the UA to remain within the flight test area. This includes, but is not limited to, considerations for wind, gross weight, and glide distances.

**e. Incident/accident reporting.** Any incident/accident and any flight operation that transgresses the lateral or vertical boundaries of the flight test area or any restricted airspace must be reported to the FAA within 24 hours. This information must be reported to the Unmanned Aircraft Program Office (UAPO), AFS-407. AFS-407 can be reached by telephone at 202-385-4631 and fax at 202-385-4651. Accidents must be reported to the National Transportation Safety Board (NTSB) per instructions contained on the NTSB Web site: [www.nts.gov](http://www.nts.gov). Further flight operations must not be conducted until the incident is reviewed by AFS-407 and authorization to resume operations is provided to Raytheon Missile Systems.

## 5. UA Pilots and Observers.

### a. UA PIC roles and responsibilities.

- (1) The UA PIC must perform crew duties for only one UA at a time.
- (2) All flight operations must have a designated UA PIC. The UA PIC has responsibility over each flight conducted and is accountable for the UA flight operation.

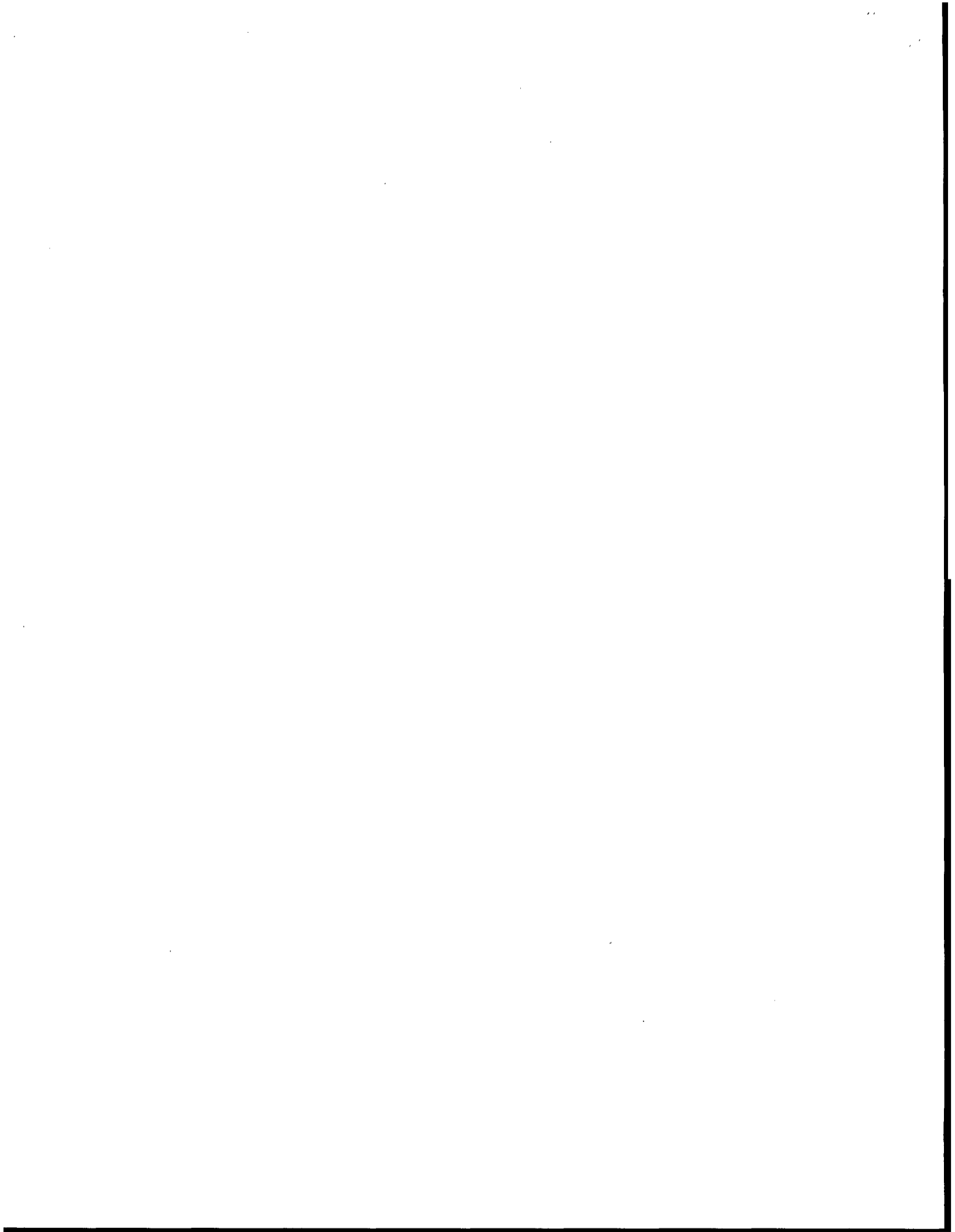

(3) The UA PIC is responsible for the safety of the UA as well as persons and property along the UA flight path. This includes, but is not limited to, collision avoidance and the safety of persons and property in the air and on the ground.

(4) The UA PIC must avoid densely populated areas (§ 91.319) and exercise increased vigilance when operating within or in the vicinity of published airway boundaries.

**b. UA PIC certification and ratings requirements.**

(1) The UA PIC must hold and be in possession of, at a minimum, an FAA private pilot certificate, with either an airplane, rotorcraft, or powered-lift category; and single- or multiengine class ratings, appropriate to the type of UA being operated.

(2) The UA PIC must have and be in possession of a valid second-class airman medical certificate issued under 14 CFR part 67, Medical Standards and Certification.

**c. UA PIC currency, flight review, and training.**

(1) No person may act as pilot in command of an unmanned aircraft unless that person has made at least three takeoffs and three landings in manned aircraft within the preceding 90 days acting as the sole manipulator of the flight controls.

(2) The UA PIC must have a flight review in manned aircraft every 24 calendar months in accordance with § 61.56, Flight review.

(3) The UA PIC must maintain currency in unmanned aircraft in accordance with Raytheon Missile Systems company procedures.

(4) The UA PIC must have a flight review in unmanned aircraft every 24 calendar months in accordance with Raytheon Missile Systems company procedures.

(5) All UA PICs must have successfully completed applicable Raytheon Missile Systems training for the UAS.

**d. Supplemental UA pilot roles and responsibilities.**

(1) Any additional UA pilot(s) assigned to a crew station during UA flight operations will be considered a supplemental UA pilot.

(2) A supplemental UA pilot assists the PIC in the operation of the UA and may do so at the same or a different control station as the PIC. The UA PIC will have operational override capability over any supplemental UA pilots, regardless of position.

(3) A supplemental UA pilot must perform crew duties for only one UA at a time.

**e. Supplemental UA pilot certification.**

(1) The supplemental UA PIC need not be a certificated pilot, but must have successfully completed a recognized private pilot ground school program.

(2) All supplemental pilots must have and be in possession of a valid second-class airman medical certificate issued under 14 CFR part 67, Medical Standards and Certification.

**f. Supplemental UA pilot currency, flight review, and training.**

(1) All UA pilots must maintain currency in unmanned aircraft in accordance with Raytheon Missile Systems company procedures.

(2) All UA pilots must have a flight review in unmanned aircraft every 24 calendar months in accordance with Raytheon Missile Systems company procedures.

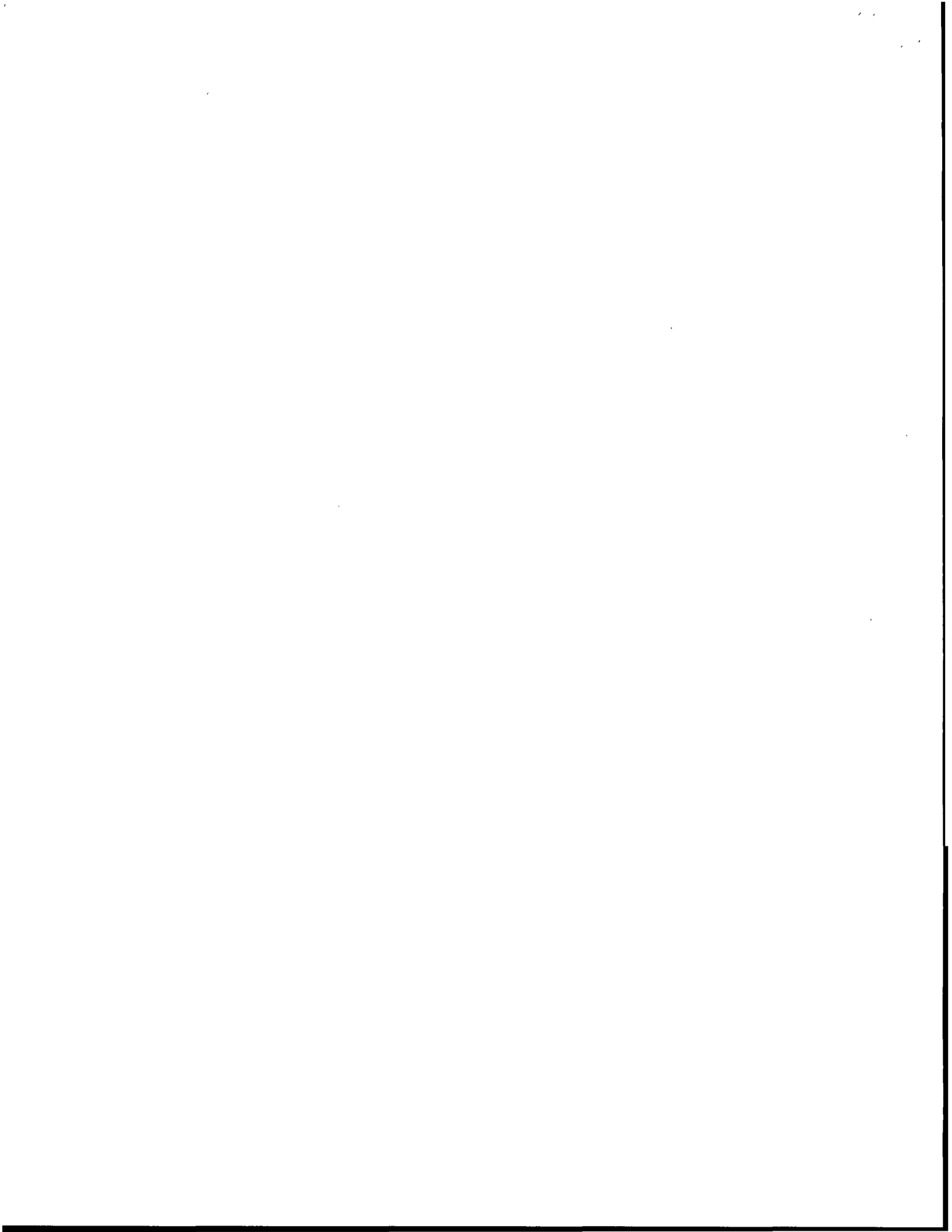

December 14, 2010

(3) All UA pilots must have successfully completed applicable Raytheon Missile Systems training for the UAS.

**g. Observer roles and responsibilities.** The task of the observer is to provide the UA PIC(s) with instructions to maneuver the UA clear of any potential collision with other traffic. To satisfy these requirements:

(1) The observer must perform crew duties for only one UA at a time.

(2) At no time will the observer permit the UA to operate beyond the line-of-sight necessary to ensure maneuvering information can be reliably determined.

**(3) At no time will the observer conduct his/her duties more than one (1) nautical mile laterally or 2000 feet vertically from the UA.**

(4) An observer must maintain continuous visual contact with the UA to discern UA attitude and trajectory in relation to conflicting traffic.

(5) Observers must continually scan the airspace for other aircraft that pose a potential conflict.

(6) All flight operations conducted in the flight test area must have an observer to perform traffic avoidance and visual observation to fulfill the see-and-avoid requirement of § 91.113, Right-of-way rules: Except water operations.

**h. Observer certification.**

(1) All observers must either hold, at a minimum, an FAA private pilot license or must have successfully completed specific observer training acceptable to the FAA. An observer does not require currency as a pilot.

(2) All observers must have in their possession a valid second-class airman medical certificate issued under part 67.

**i. Observer training.**

(1) All observers must be thoroughly trained, be familiar with, and possess operational experience with the equipment being used. Such training is necessary for observation and detection of other aircraft for collision avoidance purposes as outlined in the Raytheon Missile Systems program letter.

(2) All observers must have successfully completed applicable Raytheon Missile Systems training for the UAS.

**6. Equipage.**

**a.** The UAS must be equipped with an operable transponder with Mode C or Mode S, and two-way communications equipment allowing communications between the UA pilot, observers, all UAS control stations, and ATC.

**b.** The UA and chase aircraft must be equipped with operable navigation, position, and/or strobe/anti-collision lights. Strobe/anti-collision lights must be illuminated during all operations.

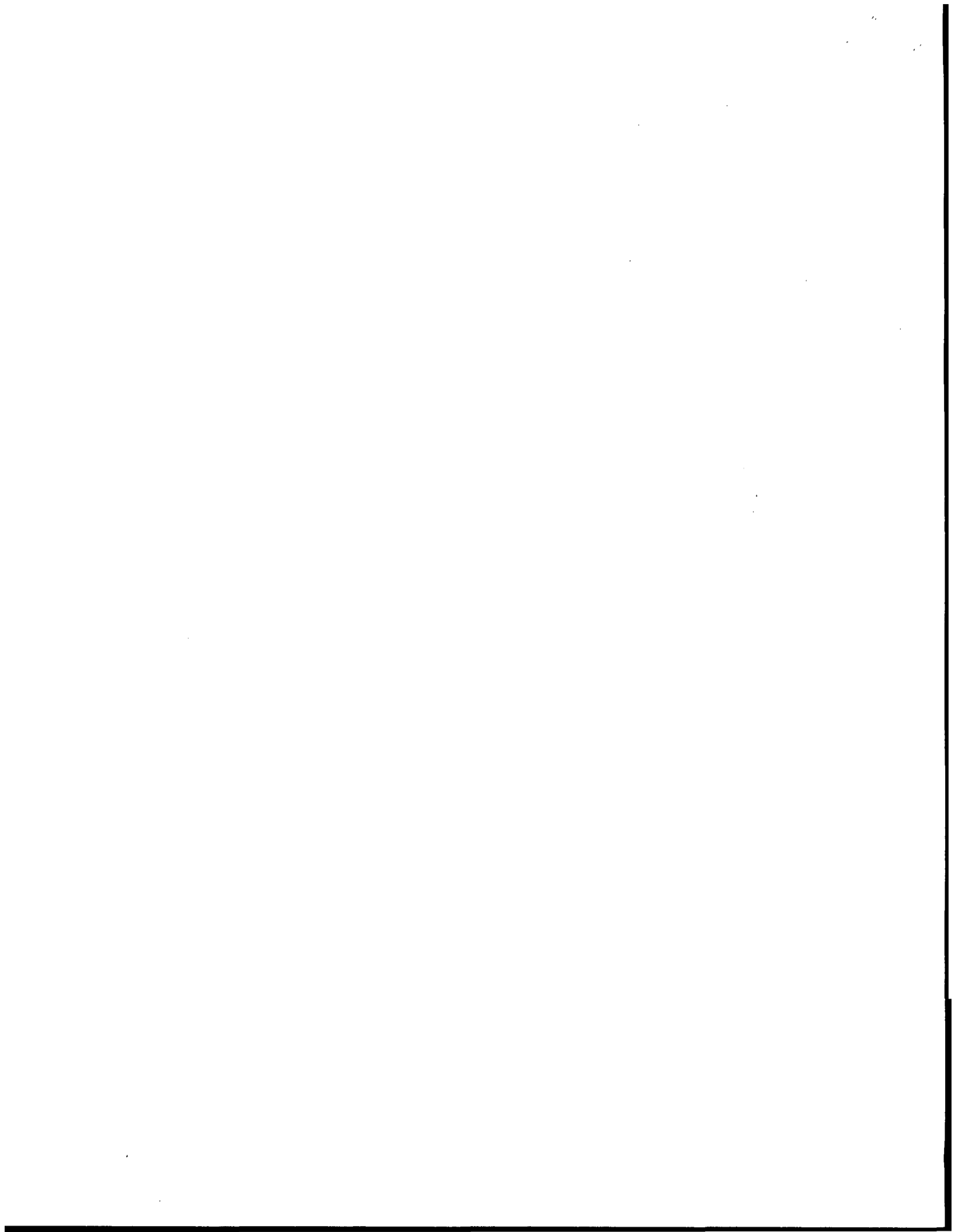



**7. Communications.**

**a. Before UA flights.**

(1) Before conducting operations, the frequency spectrum used for operation and control of the UA must be approved by the Federal Communications Commission or other appropriate government oversight agency.

(2) Raytheon shall contact Air Traffic Control prior to flight operations. Raytheon shall select and transmit transponder code 1200 unless otherwise directed by local Air Traffic Control. Upon initial contact with ATC, the UA PIC must indicate the experimental nature in accordance with § 91.319.

**b. During UA flights.**

(1) Appropriate air traffic frequencies must be monitored during flight operations.

(2) All UA positions must maintain two-way communications with each other during all operations. If unable to maintain two-way communication, the UA PIC will expeditiously return the UA to its base of operations while remaining within the flight test area and conclude the flight operation.

**8. Flight Conditions.**

**a. Daylight operations.** All flight operations must be conducted during daylight hours in visual meteorological conditions (VMC), including cloud clearance minimums as specified in § 91.155, Basic VFR weather minimums. Flight operation in instrument meteorological conditions (IMC) is not permitted.

**b. Prohibitions.**

(1) The UA is prohibited from aerobatic flight, that is, an intentional maneuver involving an abrupt change in the UA's attitude, an abnormal acceleration, or other flight action not necessary for normal flight. (See § 91.303, Aerobatic flight.)

(2) Flight operations must not involve carrying hazardous material or the dropping of any objects or external stores.

(3) No individual control station may be used to operate more than one UA at one time.

**c. Transponder requirements.** The UA must operate an approved operational Mode C or Mode S altitude encoding transponder during all flight operations.

**d. Transponder failure.** In the event of transponder failure, the UA must conclude all flight operations and expeditiously return to its base of operations within the prescribed limitations of this authorization.

**e. Notice to airman.** Raytheon Missile Systems must request the issuance of a Notice to Airman (NOTAM) through the appropriate FAA Automated Flight Service Station at least 24 hours before flight operation.

**9. Flight Termination and Lost Link Procedures.**

**a. Flight termination.** In accordance with Raytheon Missile Systems program letter, dated 09/20/2010, flight operations must be discontinued at any point that safe operation of the UA cannot be maintained or if hazard to persons or property is imminent.

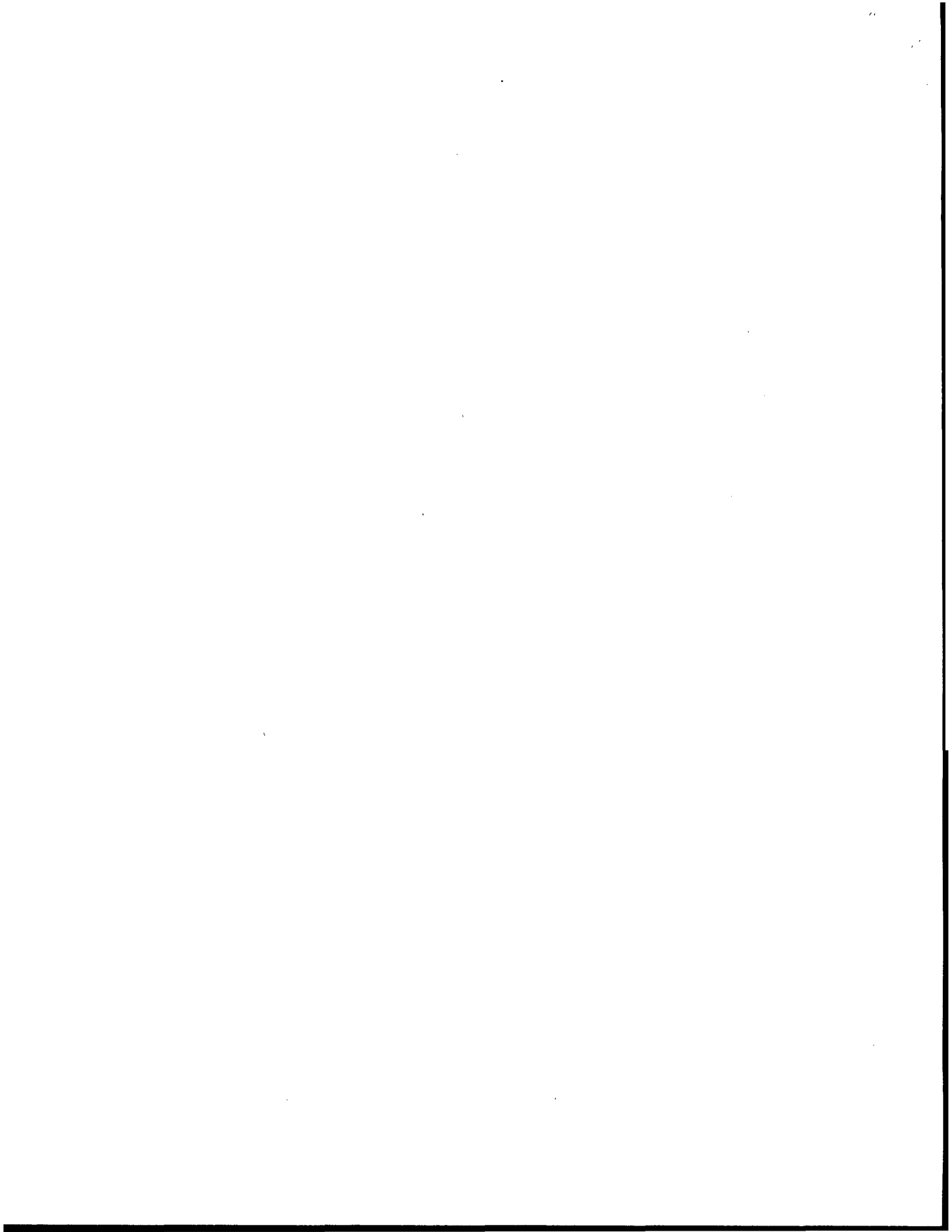

December 14, 2010

**b. Lost link procedures.** In the event of lost link, the UA must provide a means of automatic recovery that ensures airborne operations are predictable and that the UA remains within the flight test area. The observer, all other UAS control stations, and the appropriate ATC facility will be immediately notified of the lost link condition and the expected UA response.

**10. Maintenance and Inspection.**

**a. General requirements.** The UAS must not be operated unless it is inspected and maintained in accordance with the FAA-approved Cobra UAS Inspection Program, dated 04/21/2008, or later approved FAA revision. Raytheon Missile Systems must establish and maintain aircraft maintenance records (see paragraph 10(d) below).

**b. Inspections.** No person may operate this UAS unless within the preceding 12 calendar months unless it has had a condition inspection performed according to the Cobra UAS Inspection Program, dated 04/21/2008. The UAS must also have been found to be in a condition for safe operation. This inspection will be recorded in the UAS maintenance records as described in paragraph 10(d) below.

**c. Authorized inspectors.** Only those individuals trained and authorized by Raytheon Missile Systems and acceptable to the FAA may perform the inspections and maintenance required by these operating limitations.

**d. Maintenance and inspection records.** Maintenance and inspections of the UAS must be recorded in the UAS maintenance records. The following information must be recorded:

(1) Maintenance record entries must include a description of the work performed, the date of completion for the work, the UAS's total time-in-service, and the name and signature of the person performing the work.

(2) Inspection entries must contain the following, or a similarly worded, statement: *I certify that this UAS was inspected on (date), in accordance with the scope and detail of the Raytheon Missile Systems Cobra UAS Inspection Program, and was found to be in a condition for safe operation.*

(3) UAS instruments and equipment required to be installed must be inspected and maintained in accordance with the requirements of the Raytheon Missile Systems Cobra UAS Inspection Program. Any maintenance or inspection of this equipment must be recorded in the UAS maintenance records.

(4) No person may operate this UAS unless the altimeter system and transponder have been tested within the preceding 24 calendar months in accordance with § 91.413, ATC transponder tests and inspections. These inspections will be recorded in the UAS maintenance records.

**11. Information Reporting.** Raytheon Missile Systems will provide the following information on a monthly basis, via email, to Mr. Donald Grampp of the FAA UAPO. Mr. Grampp's email address is [donald.e.grampp@faa.gov](mailto:donald.e.grampp@faa.gov). A copy of the report shall be provided to AIR-200.

- a. Number of flights conducted under this certificate.
- b. Pilot duty time per flight.
- c. Unusual equipment malfunctions (hardware or software).
- d. Deviations from ATC instructions.

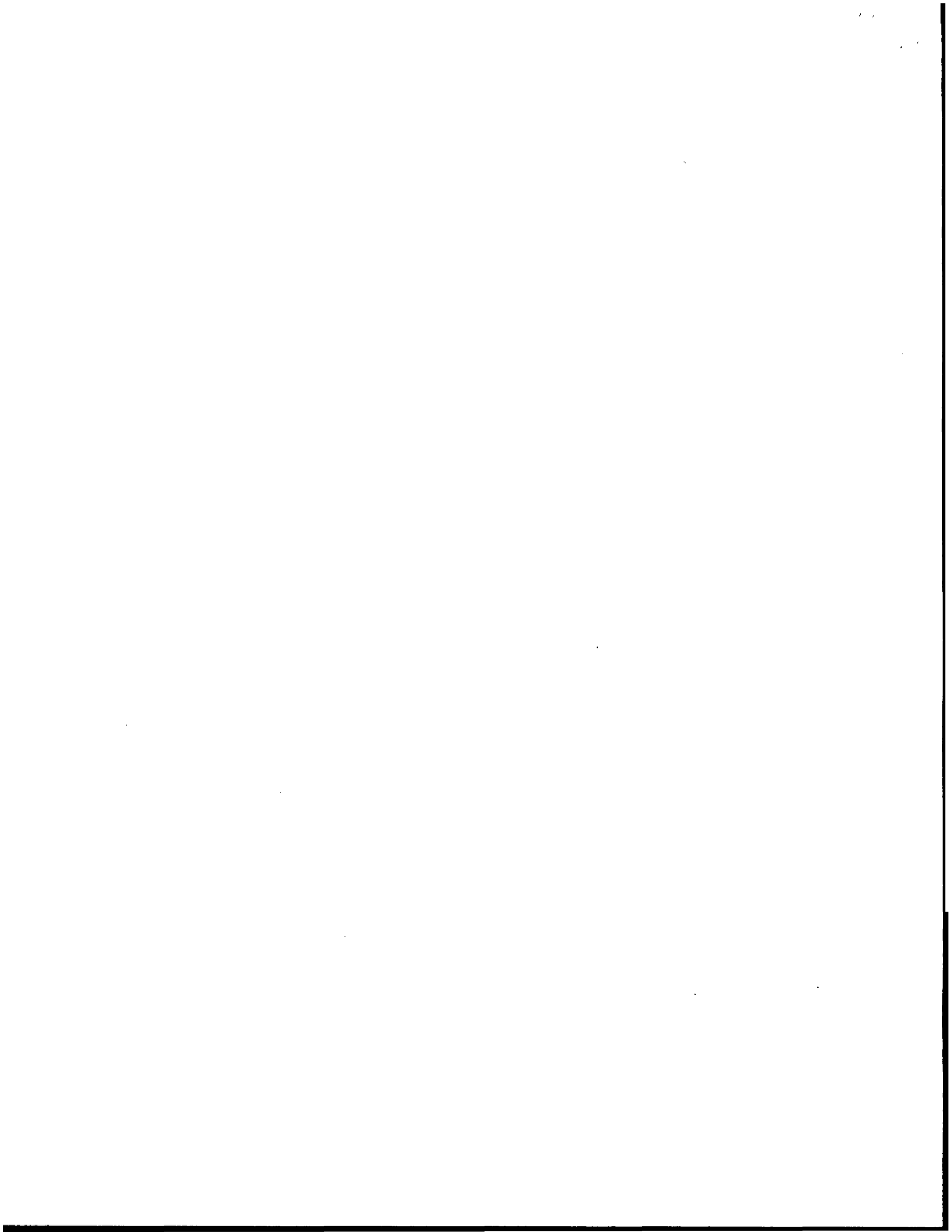

December 14, 2010

e. Unintended entry into lost link flight mode that results in a course change.

## **12. Revisions and Other Provisions.**

**a. Experimental certificates, program letters, and operating limitations.** The experimental certificate, FAA-accepted Raytheon Missile Systems program letter, and operating limitations cannot be reissued, renewed, or revised without application being made to the Van Nuys Manufacturing Inspection District (MIDO), in coordination with AIR-200. AIR-200 will be responsible for FAA Headquarters internal coordination with the Aircraft Certification Service, Flight Standards Service, Air Traffic Organization, Office of the Chief Council, and Office of Rulemaking.

**b. Certificates of waiver or authorization.** The Production and Airworthiness Division, AIR-200 and the Phoenix MIDO shall be notified immediately if there is any plan for requesting a Certificate of Authorization or Waiver (COA) for UAS operations during the time period the Experimental Certificate is in effect. If the aircraft is authorized to operate under a COA, Raytheon must determine that the aircraft is in a condition for safe operation and appropriately configured for the purpose intended. A record entry will be made by an appropriately rated person to document that finding in the aircraft logbook.

**c. Amendments and cancellations.** The provisions and limitations annotated in this operational approval may be amended or cancelled at any time as deemed necessary by the FAA.

**d. Reviews of revisions.** All revisions to Raytheon Missile Systems FAA-approved Inspection Program must be reviewed and accepted by the Scottsdale Flight Standards District Office.

## **13. UAS Modifications.**

**a. Software and system changes.** All software and system changes will be documented as part of the normal maintenance procedures and will be available for inspection. All software and system changes must be inspected and approved per FAA-approved Cobra UAS Inspection Program, dated 04/21/2008. All software changes to the aircraft and control station are categorized as major changes, and must be provided to AIR-200 in summary form at the time they are incorporated.

**b. Major modifications.** All major modifications, whether performed under the experimental certificate, COA, or other authorizations, that could potentially affect the safe operation of the system, must be documented and provided to the AIR-200 before operating the aircraft under this certificate. Major modifications incorporated under COA or other authorizations need to be provided only if the aircraft is flown under these authorizations during the effective period of the experimental certificate.

End of Limitations

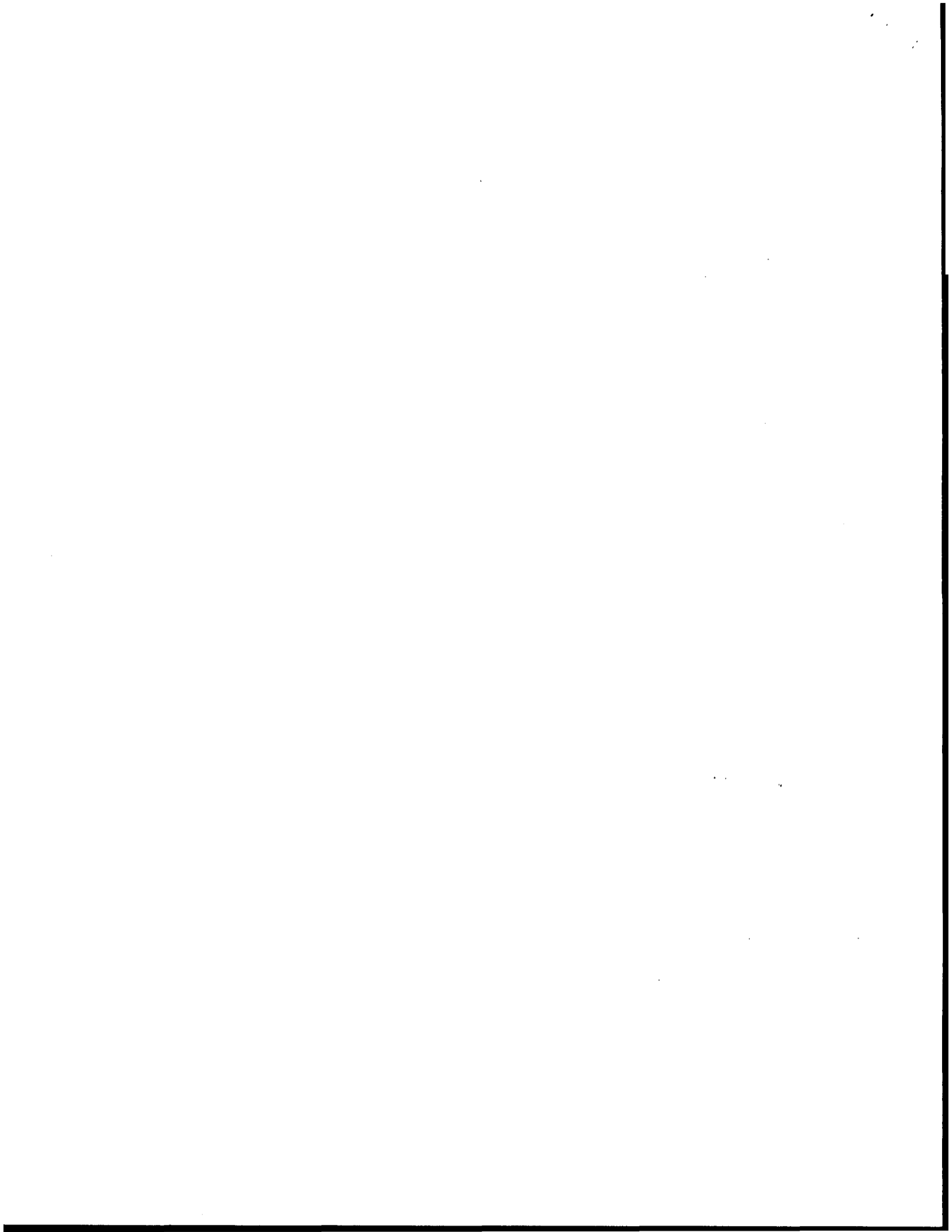

December 14, 2010

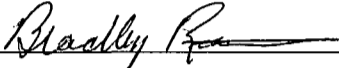
  
\_\_\_\_\_  
Bradley Roon  
Aviation Safety Inspector  
17777 North Perimeter Drive, Suite 103  
Scottsdale, Arizona 85255

Date: 12/14/2010

**The Special Airworthiness Certificate and accompanying Operating Limitations expire on December 14, 2011.**

**I certify that I have read and understand the operating limitations, and conditions, that are a part of the Special Airworthiness Certificate; FAA Form 8130-7 issued on December 14, 2010, for the purpose of Research and Development, Market Survey, and/or Crew Training.**

**This Special Airworthiness Certificate is issued for the Raytheon Missile Systems, UA model "Cobra," serial number 006, registration number N606RN.**

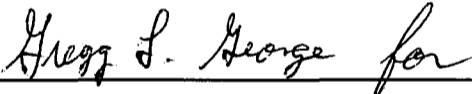
  
\_\_\_\_\_  
Applicant:

Date: December 14, 2010

**Name: Donald L. Newman  
Title: Director Unmanned Systems  
Company: Raytheon Missile Systems**

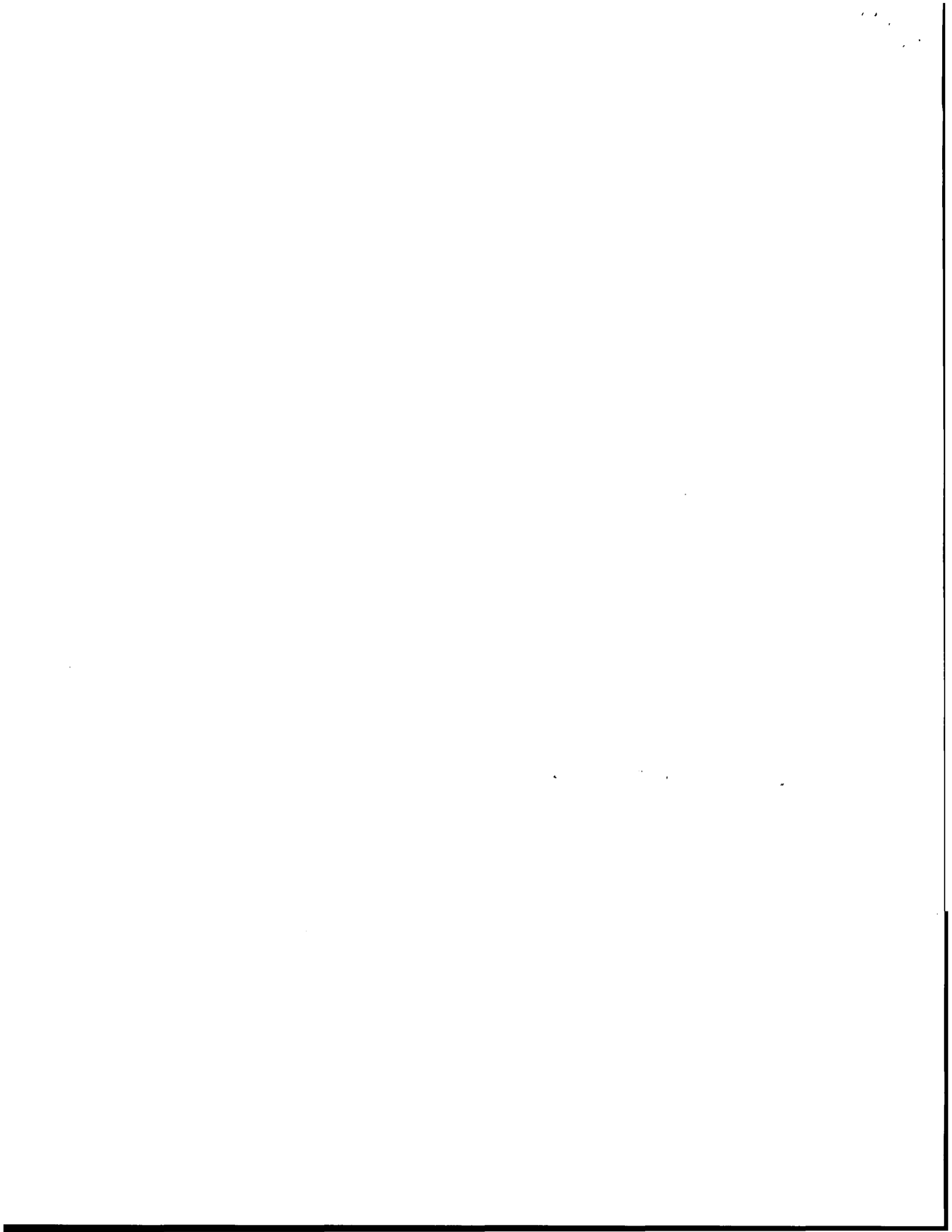



FAA FORM 8130-6, APPLICATION FOR U.S. AIRWORTHINESS CERTIFICATE

Form Approved O.M.B. No. 2120-0018  
12/31/2010

Accepted JJ Feb/02/2010

U.S. Department of Transportation Federal Aviation Administration		APPLICATION FOR U.S. AIRWORTHINESS CERTIFICATE		INSTRUCTIONS - Print or type. Do not write in shaded areas; these are for FAA use only. Submit original only to an authorized FAA Representative. If additional space is required, use attachment. For special flight permits complete Sections II, VI and VII as applicable.					
I. AIRCRAFT DESIGNATION	1. REGISTRATION MARK	2. AIRCRAFT BUILDER'S NAME (Make)	3. AIRCRAFT MODEL DESIGNATION	4. YR. MFR.	FAA CODING				
	N606RN	Raytheon	Cobra	2006					
	5. AIRCRAFT SERIAL NO.	6. ENGINE BUILDER'S NAME (Make)	7. ENGINE MODEL DESIGNATION						
	006	Desert Aircraft	DA-150						
8. NUMBER OF ENGINES	9. PROPELLER BUILDER'S NAME (Make)	10. PROPELLER MODEL DESIGNATION			11. AIRCRAFT IS (Check if applicable)				
1	Mejzlik	28 x 12-3B			IMPORT				
APPLICATION IS HEREBY MADE FOR: (Check applicable items)									
<input type="checkbox"/> STANDARD AIRWORTHINESS CERTIFICATE (Indicate Category) <input type="checkbox"/> NORMAL <input type="checkbox"/> UTILITY <input type="checkbox"/> ACROBATIC <input type="checkbox"/> TRANSPORT <input type="checkbox"/> COMMUTER <input type="checkbox"/> BALLOON <input type="checkbox"/> OTHER									
<input checked="" type="checkbox"/> SPECIAL AIRWORTHINESS CERTIFICATE (Check appropriate items) <b>UNMANNED AIRCRAFT</b>									
II. CERTIFICATION REQUESTED	7. PRIMARY								
	9. LIGHT-SPORT (Indicate Class)		AIRPLANE	POWER-PARACHUTE	WEIGHT-SHIFT-CONTROL	GLIDER	LIGHTER THAN AIR		
	12. LIMITED								
	5. PROVISIONAL (Indicate Class)		CLASS I		CLASS II				
	3. RESTRICTED (Indicate operation(s) to be conducted)	1. AGRICULTURE AND PEST CONTROL		2.	AERIAL SURVEY		3.	AERIAL ADVERTISING	
		4. FOREST (Wildlife Conservation)		5.	PATROLLING		6.	WEATHER CONTROL	
		10. OTHER (Specify)							
	4. EXPERIMENTAL (Indicate operation(s) to be conducted)	1. RESEARCH AND DEVELOPMENT		2.	AMATEUR BUILT		3.	EXHIBITION	
		4. AIR RACING		5.	CREW TRAINING		6.	MARKET SURVEY	
		10. TO SHOW COMPLIANCE WITH THE CFR		7.	OPERATING (Primary Category) KIT BUILT AIRCRAFT				
		8. OPERATING LIGHT-SPORT		8A.	Existing Aircraft without an airworthiness certificate & do not meet § 103.1				
			8B.	Operating Light-Sport Kit-Built					
		8C.	Operating light-sport previously issued special light-sport category airworthiness certificate under § 21.190						
8. SPECIAL FLIGHT PERMIT (Indicate operation(s) to be conducted, then complete Section VI or VII as applicable on reverse side)	1. FERRY FLIGHT FOR REPAIRS, ALTERATIONS, MAINTENANCE, OR STORAGE								
	2. EVACUATION FROM AREA OF IMPENDING DANGER								
	3. OPERATION IN EXCESS OF MAXIMUM CERTIFICATED TAKE-OFF WEIGHT								
	4. DELIVERING OR EXPORTING		5.	PRODUCTION FLIGHT TESTING					
6. CUSTOMER DEMONSTRATION FLIGHTS									
C. <input type="checkbox"/> MULTIPLE AIRWORTHINESS CERTIFICATE (check ABOVE "Restricted Operation" and "Standard" or "Limited" as applicable)									
III. OWNER'S CERTIFICATION	A. REGISTERED OWNER (As shown on certificate of aircraft registration)			IF DEALER, CHECK HERE →					
	NAME Raytheon Company			ADDRESS PO Box 11337, Tucson AZ 85734-1337					
	B. AIRCRAFT CERTIFICATION BASIS (Check applicable blocks and complete items as indicated)				AIRWORTHINESS DIRECTIVES (Check if all applicable AD's are complied with and give the number of the last AD SUPPLEMENT available in the biweekly series as of the date of application) AD Bi-Weekly #2009-18				
	AIRCRAFT SPECIFICATION OR TYPE CERTIFICATE DATA SHEET (Give No. and Revision No.) N/A				AIRCRAFT LISTING (Give page number(s)) N/A				
	AIRCRAFT LISTING (Give page number(s)) N/A				SUPPLEMENTAL TYPE CERTIFICATE (List number of each STC incorporated) N/A				
	C. AIRCRAFT OPERATION AND MAINTENANCE RECORDS								
<input checked="" type="checkbox"/> CHECK IF RECORDS IN COMPLIANCE WITH 14 CFR Section 91.417		TOTAL AIRFRAME HOURS 0.3		EXPERIMENTAL ONLY (Enter hours flown since last certificate issued or renewed) 0.0					
D. CERTIFICATION - I hereby certify that I am the registered owner (or his agent) of the aircraft described above, that the aircraft is registered with the Federal Aviation Administration in accordance with Title 49 of the United States Code 44101 et seq. and applicable Federal Aviation Regulations, and that the aircraft has been inspected and is airworthy and eligible for the airworthiness certificate requested.									
DATE OF APPLICATION 28 Oct 2009		NAME AND TITLE (Print or type) Donald L. Newman, Director, Unmanned Systems			SIGNATURE <i>Donald L. Newman</i>				
IV. INSPECTION AGENCY VERIFICATION	A. THE AIRCRAFT DESCRIBED ABOVE HAS BEEN INSPECTED AND FOUND AIRWORTHY BY: (Complete the section only if 14 CFR part 21.183(d) applies.)								
	14 CFR part 121 CERTIFICATE HOLDER (Give Certificate No.)		CERTIFICATED MECHANIC (Give Certificate No.)		CERTIFICATED REPAIR STATION (Give Certificate No.)				
	AIRCRAFT MANUFACTURER (Give name or firm)								
	DATE	TITLE	SIGNATURE						
V. FAA REPRESENTATIVE CERTIFICATION	(Check ALL applicable block items A and B)								
	A. I find that the aircraft described in Section I or VII meets requirements for				<input checked="" type="checkbox"/> THE CERTIFICATE REQUESTED				
	B. Inspection for a special permit under Section VII was conducted by:				<input type="checkbox"/> AMENDMENT OR MODIFICATION OF CURRENT AIRWORTHINESS CERTIFICATE				
	DATE	MIDO/FSDO Office	DESIGNEE'S SIGNATURE AND NO.		FAA INSPECTOR'S SIGNATURE				
10/28/09	Phoenix mmo Nm-50	<i>Donald L. Newman</i>		<i>Chris Napitano</i>					

7

<b>VI. PRODUCTION FLIGHT TESTING</b>	A. MANUFACTURER			
	NAME		ADDRESS	
	B. PRODUCTION BASIS <i>(Check applicable item)</i>			
	PRODUCTION CERTIFICATE <i>(Give production certificate number)</i>		→	
	TYPE CERTIFICATE ONLY			
	APPROVED PRODUCTION INSPECTION SYSTEM			
C. GIVE QUANTITY OF CERTIFICATES REQUIRED FOR OPERATING NEEDS				
DATE OF APPLICATION		NAME AND TITLE <i>(Print or Type)</i>	SIGNATURE	
<b>VII. SPECIAL FLIGHT PERMIT PURPOSES OTHER THAN PRODUCTION FLIGHT TEST</b>	A. DESCRIPTION OF AIRCRAFT			
	REGISTERED OWNER		ADDRESS	
	BUILDER <i>(Make)</i>		MODEL	
	SERIAL NUMBER		REGISTRATION MARK	
	B. DESCRIPTION OF FLIGHT			
	FROM		TO	
	VIA		DEPARTURE DATE	DURATION
	C. CREW REQUIRED TO OPERATE THE AIRCRAFT AND ITS EQUIPMENT			
	PILOT	CO-PILOT	FLIGHT ENGINEER	OTHER <i>(Specify)</i>
	D. THE AIRCRAFT DOES NOT MEET THE APPLICABLE AIRWORTHINESS REQUIREMENTS AS FOLLOWS:			
	E. THE FOLLOWING RESTRICTIONS ARE CONSIDERED NECESSARY FOR SAFE OPERATION: <i>(Use attachment if necessary)</i>			
	F. CERTIFICATION – I hereby certify that I am the registered owner (or his agent) of the aircraft described above; that the aircraft is registered with the Federal Aviation Administration in accordance with Title 49 of the United States Code 44101 <u>et seq.</u> , and applicable Federal Aviation Regulations; and that the aircraft has been inspected and is safe for the flight described.			
DATE		NAME AND TITLE <i>(Print or Type)</i>	SIGNATURE	
<b>VIII. AIRWORTHINESS DOCUMENTATION (FAA/DESIGNEE use only)</b>	<input checked="" type="checkbox"/> A. Operating Limitations and Markings in Compliance with 14 CFR Section 91.9, as applicable.		G. Statement of Conformity, FAA Form 8130-9 <i>(Attach when required)</i>	
	<input checked="" type="checkbox"/> B. Current Operating Limitations Attached		H. Foreign Airworthiness Certification for Import Aircraft <i>(Attach when required)</i>	
	<input checked="" type="checkbox"/> C. Data, Drawings, Photographs, etc. <i>(Attach when required)</i>		<input checked="" type="checkbox"/> I. Previous Airworthiness Certificate Issued in Accordance with 14 CFR Section <u>21.191(a)(c) &amp; (f)</u> <i>CAR</i> (Original Attached)	
	<input checked="" type="checkbox"/> D. Current Weight and Balance information Available in Aircraft		<input checked="" type="checkbox"/> J. Current Airworthiness Certificate Issued in Accordance with 14 CFR Section <u>21.191(a)(c) &amp; (f)</u> (Copy Attached)	
	<input checked="" type="checkbox"/> E. Major Repair and Alteration, FAA Form 337 <i>(Attach when required)</i>		<input checked="" type="checkbox"/> K. Light-Sport Aircraft Statement of Compliance, FAA Form 8130-15 <i>(Attach when required)</i>	
	<input checked="" type="checkbox"/> F. This inspection Recorded in Aircraft Records			

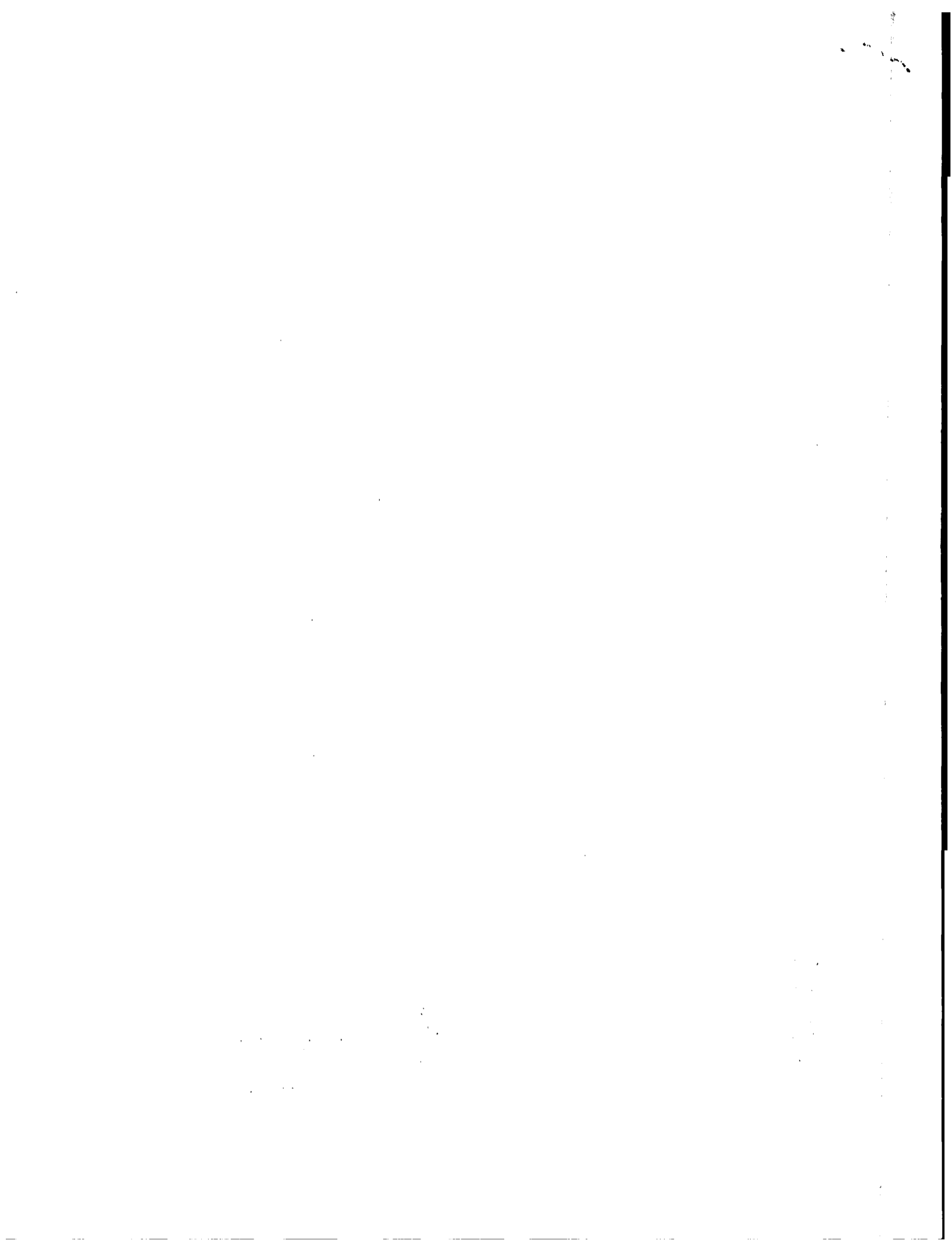

UNITED STATES OF AMERICA  
 DEPARTMENT OF TRANSPORTATION - FEDERAL AVIATION ADMINISTRATION  
**SPECIAL AIRWORTHINESS CERTIFICATE**

<b>A</b>	CATEGORY/DESIGNATION	Experimental (Unmanned Aircraft)	
	PURPOSE	Research and Development, Crew Training, and/or Market Survey	
<b>B</b>	MANUFACTURER	NAME	N/A
		ADDRESS	N/A
<b>C</b>	FLIGHT	FROM	N/A
		TO	N/A
<b>D</b>	N- 606RN	SERIAL NO.	006
	BUILDER Raytheon Company	MODEL	Cobra
<b>E</b>	DATE OF ISSUANCE	October 28, 2009	EXPIRY October 28, 2010
	OPERATING LIMITATIONS DATED	10/28/09	(ARE PART OF THIS CERTIFICATE)
<b>E</b>	SIGNATURE OF FAA REPRESENTATIVE <i>Cindy Napolitano</i> Cindy Napolitano	DESIGNATION OR OFFICE NO.	Phoenix MIDO NM-50

Any alteration, reproduction or misuse of this certificate may be punishable by a fine not exceeding \$1,000 or imprisonment not exceeding 3 years, or both. THIS CERTIFICATE MUST BE DISPLAYED IN THE AIRCRAFT IN ACCORDANCE WITH APPLICABLE TITLE 14, CODE OF FEDERAL REGULATIONS (CFR).

<b>A</b>	This airworthiness certificate is issued under the authority of Public Law 104-6, 49 United States Code (USC) 44704 and Title 14 Code of Federal Regulations (CFR).
<b>B</b>	The airworthiness certificate authorizes the manufacturer named on the reverse side to conduct production flight tests, and only production flight tests, of aircraft registered in his name. No person may conduct production flight tests under this certificate: (1) Carrying persons or property for compensation or hire; and/or (2) Carrying persons not essential to the purpose of the flight.
<b>C</b>	This airworthiness certificate authorizes the flight specified on the reverse side for the purpose shown in Block A.
<b>D</b>	This airworthiness certificate certifies that as of the date of issuance, the aircraft to which issued has been inspected and found to meet the requirements of the applicable CFR. The aircraft does not meet the requirements of the applicable comprehensive and detailed airworthiness code as provided by Annex 8 to the Convention On International Civil Aviation. No person may operate the aircraft described on the reverse side: (1) except in accordance with the applicable CFR and in accordance with conditions and limitations which may be prescribed by the Administrator as part of this certificate; (2) over any foreign country without the special permission of that country.
<b>E</b>	Unless sooner surrendered, suspended, or revoked, this airworthiness certificate is effective for the duration and under the conditions prescribed in 14 CFR, Part 21, Section 21.181 or 21.217.

UNITED STATES OF AMERICA  
DEPARTMENT OF TRANSPORTATION - FEDERAL AVIATION ADMINISTRATION  
**SPECIAL AIRWORTHINESS CERTIFICATE**

<b>A</b>	CATEGORY/DESIGNATION	Experimental (Unmanned Aircraft)		
	PURPOSE	Research and Development, Crew Training, and/or Market Survey		
<b>B</b>	MANUFACTURER	NAME	N/A	
		ADDRESS	N/A	
<b>C</b>	FLIGHT	FROM	N/A	
		TO	N/A	
<b>D</b>	N- 606RN	SERIAL NO.	006	
	BUILDER	Raytheon Company	MODEL	Cobra
	DATE OF ISSUANCE	October 28, 2009	EXPIRY	October 28, 2010
	OPERATING LIMITATIONS DATED	10/28/09	(ARE PART OF THIS CERTIFICATE)	
<b>E</b>	SIGNATURE OF FAA REPRESENTATIVE		DESIGNATION OR OFFICE NO.	
	Cindy Napolitano		Phoenix MIDO NM-50	

Any alteration, reproduction or misuse of this certificate may be punishable by a fine not exceeding \$1,000 or imprisonment not exceeding 3 years, or both. THIS CERTIFICATE MUST BE DISPLAYED IN THE AIRCRAFT IN ACCORDANCE WITH APPLICABLE TITLE 14, CODE OF FEDERAL REGULATIONS (CFR).

<b>A</b>	This airworthiness certificate is issued under the authority of Public Law 104-6, 49 United States Code (USC) 44704 and Title 14 Code of Federal Regulations (CFR).
<b>B</b>	The airworthiness certificate authorizes the manufacturer named on the reverse side to conduct production flight tests, and only production flight tests, of aircraft registered in his name. No person may conduct production flight tests under this certificate: (1) Carrying persons or property for compensation or hire; and/or (2) Carrying persons not essential to the purpose of the flight.
<b>C</b>	This airworthiness certificate authorizes the flight specified on the reverse side for the purpose shown in Block A.
<b>D</b>	This airworthiness certificate certifies that as of the date of issuance, the aircraft to which issued has been inspected and found to meet the requirements of the applicable CFR. The aircraft does not meet the requirements of the applicable comprehensive and detailed airworthiness code as provided by Annex 8 to the Convention On International Civil Aviation. No person may operate the aircraft described on the reverse side: (1) except in accordance with the applicable CFR and in accordance with conditions and limitations which may be prescribed by the Administrator as part of this certificate; (2) over any foreign country without the special permission of that country.
<b>E</b>	Unless sooner surrendered, suspended, or revoked, this airworthiness certificate is effective for the duration and under the conditions prescribed in 14 CFR, Part 21, Section 21.181 or 21.217.



UNITED STATES OF AMERICA  
DEPARTMENT OF TRANSPORTATION - FEDERAL AVIATION ADMINISTRATION  
**SPECIAL AIRWORTHINESS CERTIFICATE**

<b>A</b>	CATEGORY/DESIGNATION	Experimental (Unmanned Aircraft)		
	PURPOSE	Research and Development, Crew Training, and/or Market Survey		
<b>B</b>	MANUFACTURER	NAME	N/A	
		ADDRESS	N/A	
<b>C</b>	FLIGHT	FROM	N/A	
		TO	N/A	
<b>D</b>	N- 606RN	SERIAL NO.	006	
	BUILDER	Raytheon Company	MODEL	Cobra
	DATE OF ISSUANCE	October 24, 2008	EXPIRY	October 24, 2009
	OPERATING LIMITATIONS DATED	10/24/08	(ARE PART OF THIS CERTIFICATE)	
<b>E</b>	SIGNATURE OF FAA REPRESENTATIVE	DESIGNATION OR OFFICE NO.		
	<i>Bradley Roon</i> Bradley Roon	Phoenix MIDO NM-50		

Any alteration, reproduction or misuse of this certificate may be punishable by a fine not exceeding \$1,000 or imprisonment not exceeding 3 years, or both. THIS CERTIFICATE MUST BE DISPLAYED IN THE AIRCRAFT IN ACCORDANCE WITH APPLICABLE TITLE 14, CODE OF FEDERAL REGULATIONS (CFR).

<b>A</b>	This airworthiness certificate is issued under the authority of Public Law 104-6, 49 United States Code (USC) 44704 and Title 14 Code of Federal Regulations (CFR).
<b>B</b>	The airworthiness certificate authorizes the manufacturer named on the reverse side to conduct production flight tests, and only production flight tests, of aircraft registered in his name. No person may conduct production flight tests under this certificate: (1) Carrying persons or property for compensation or hire; and/or (2) Carrying persons not essential to the purpose of the flight.
<b>C</b>	This airworthiness certificate authorizes the flight specified on the reverse side for the purpose shown in Block A.
<b>D</b>	This airworthiness certificate certifies that as of the date of issuance, the aircraft to which issued has been inspected and found to meet the requirements of the applicable CFR. The aircraft does not meet the requirements of the applicable comprehensive and detailed airworthiness code as provided by Annex 8 to the Convention On International Civil Aviation. No person may operate the aircraft described on the reverse side: (1) except in accordance with the applicable CFR and in accordance with conditions and limitations which may be prescribed by the Administrator as part of this certificate; (2) over any foreign country without the special permission of that country.
<b>E</b>	Unless sooner surrendered, suspended, or revoked, this airworthiness certificate is effective for the duration and under the conditions prescribed in 14 CFR, Part 21, Section 21.181 or 21.217.

10/28/2009



Van Nuys Manufacturing Inspection District Office  
7120 Hayvenhurst Ave, Suite 100  
Van Nuys, CA 91406

**Operating Limitations**  
**Experimental: Research and Development, Market Survey,**  
**and/or Crew Training**

<p><b>Registered Owner Name:</b> Raytheon Missile Systems</p> <p><b>Registered Owner Address:</b> Bldg M09, M/S 5 P.O. Box 11337 Tucson, AZ 85734-1337</p> <p><b>Aircraft Description:</b> Unmanned, composite, mid-wing monoplane with standard tail surfaces and a tractor engine.</p> <p><b>Aircraft Registration:</b> N606RN</p>	<p><b>Aircraft Builder:</b> Raytheon Missile Systems Bldg M09, M/S 5 P.O. Box 11337 Tucson, AZ 85734-1337</p> <p><b>Year Manufactured:</b> 2007</p> <p><b>Aircraft Serial Number:</b> 006</p> <p><b>Aircraft Model Designation:</b> Cobra</p> <p><b>Engine Model:</b> Desert Aircraft DA-150</p>
--	--

**The following conditions and limitations apply to all unmanned aircraft system (UAS) flight operations for the Raytheon Cobra while operating in the National Airspace System (NAS).**

**1. General Information.**

**a. Integrated system.** For the purposes of this special airworthiness certificate and operating limitations, the Raytheon Cobra operated by Raytheon Missile Systems is considered to be an integrated system. The system is composed of the following:

- (1) Raytheon Missile Systems, Cobra, unmanned aircraft, s/n 006,
- (2) UAS control stations, fixed, mobile, or ground-based,
- (3) Telemetry, launch, and recovery equipment,
- (4) Communications and navigation equipment, including ground and/or airborne equipment used for command and control of the Raytheon Cobra.
- (5) Equipment on the ground and in the air used for communication with other members of the flightcrew, observers, air traffic control (ATC), and other users of the NAS.

4

**b. Compliance with 14 CFR Part 61 (Certification: Pilots, Flight Instructors, and Ground Instructors) and part 91 (General Operating and Flight Rules).** Unless otherwise specified in this document, the UA pilot-in-command (PIC) and Raytheon Missile Systems must comply with all applicable sections and parts of 14 CFR including, but not limited to, parts 61 and 91.

**c. Operational requirements.**

(1) No person may operate this UAS for other than the purpose of research and development, market survey, and/or crew training, to accomplish the flight operation outlined in Raytheon Missile Systems program letter dated 09/30/2009, which describes compliance with § 21.193(d), Experimental certificates: General, and has been made available to the UA PIC.

(2) This UAS must be operated in accordance with applicable air traffic and general operating rules of part 91 and all additional limitations herein prescribed under the provisions of § 91.319(i), Aircraft having experimental certificates: Operating limitations.

(3) Raytheon Missile Systems must accumulate at least 50 flight hours under its experimental airworthiness certificate before customer crew training is permitted, in accordance with § 21.195(d), Experimental certificates: Aircraft to be used for market surveys, sales demonstrations, and customer crew training.

**d. UA condition.** The UA PIC must determine that the UA is in a condition for safe operation and in a configuration appropriate for the purpose of the intended flight.

**e. Multiple-purpose operations.** When changing between operating purposes of a multiple purpose certificate, the operator must determine that the aircraft is in a condition for safe operation and appropriate for the purpose intended. A record entry will be made by an appropriately rated person (that is, an individual authorized by the applicant and acceptable to the FAA) to document that finding in the aircraft maintenance records.

**f. Operation exceptions.** No person may operate this UA to carry property for compensation or hire (§ 91.319(a)(2)).

**g. UA markings.**

(1) This UA must be marked with its U.S. registration number in accordance with part 45 or alternative marking approval issued by the FAA Production and Airworthiness Division (AIR-200).

(2) This UA must display the word *Experimental* in accordance with § 45.23(b), Display of marks, unless otherwise granted an exemption from this requirement.

**h. Required documentation.** Before conducting the initial flight of the Cobra UAS, Raytheon Missile Systems must transmit by email a scanned copy of the Raytheon Cobra program letter, special airworthiness certificate, and operating limitations to the following FAA personnel:

(1) Debra Trindle, FAA Air Traffic Representative, Luke and Davis-Monthan Air Force Base, AZ, (623) 856-9596, email: [debra.trindle@faa.gov](mailto:debra.trindle@faa.gov).

(2) Roger Trevino, System Support Specialist, FAA Central Service Area, System Support Group, AJO2-C2, (817)-222-5595, email: [roger.trevino@faa.gov](mailto:roger.trevino@faa.gov)

(3) Richard Posey, Aviation Safety Inspector, Production and Airworthiness Division, AIR-200, (202) 267-9538, email: [richard.posey@faa.gov](mailto:richard.posey@faa.gov).

1  
2  
3  
4  
5  
6  
7  
8  
9  
10  
11  
12  
13  
14  
15  
16  
17  
18  
19  
20  
21  
22  
23  
24  
25  
26  
27  
28  
29  
30  
31  
32  
33  
34  
35  
36  
37  
38  
39  
40  
41  
42  
43  
44  
45  
46  
47  
48  
49  
50  
51  
52  
53  
54  
55  
56  
57  
58  
59  
60  
61  
62  
63  
64  
65  
66  
67  
68  
69  
70  
71  
72  
73  
74  
75  
76  
77  
78  
79  
80  
81  
82  
83  
84  
85  
86  
87  
88  
89  
90  
91  
92  
93  
94  
95  
96  
97  
98  
99  
100

**i. Change in registrant address.** Section 47.45, Change of address, requires that the FAA Aircraft Registry be notified within 30 days of any change in the aircraft registrant's address. Such notification is to be made by providing AC Form 8050-1, Aircraft Registration Application, to the FAA Aircraft Registration Branch (AFS-750) in Oklahoma City, Oklahoma.

**j. Certificate display and manual availability.** The airworthiness and registration certificates must be displayed, and the aircraft flight manual must be available to the pilot, as prescribed by the applicable sections of 14 CFR, or as prescribed by an exemption granted to Raytheon Missile Systems, in accordance with 14 CFR part 11, General Rulemaking Procedures.

**2. Program Letter.** The Raytheon Cobra program letter, dated 09/30/2009, will be used as a basis for determining the operating limitations prescribed in this document. All flight operations must be conducted in accordance with the provisions of this document.

### **3. Initial Flight Testing.**

**a. Requirements.** Flight operations must be conducted within visual line of sight of the pilot/observer. Initial flight testing must be completed upon accumulation of 25 flight hours. Following satisfactory completion of initial flight testing, the operations manager or chief pilot must certify in the records that the aircraft has been shown to comply with § 91.319(b). Compliance with § 91.319(b) must be recorded in the aircraft records with the following, or a similarly worded, statement:

*I certify that the prescribed flight test hours have been completed and the aircraft is controllable throughout its normal range of speeds and throughout all maneuvers to be executed, has no hazardous operating characteristics or design features, and is safe for operation. The following aircraft operating data has been demonstrated during the flight testing: speeds Vx \_\_\_\_\_, and Vy \_\_\_\_\_, and the weight \_\_\_\_\_ and CG location \_\_\_\_\_ at which they were obtained.*

**b. Aircraft operations for the purpose of market surveys, sales demonstrations, and customer crew training.** These operations cannot be performed until 50 flight hours have been accomplished. An entry in the aircraft maintenance records is required as evidence of compliance.

### **4. Authorized Flight Operations Area.**

**a.** The main base of operations for the UA shall be:

Unmanned Vehicles International, Inc  
2595 North Sagebrush Road, Whetstone, AZ  
±4 Miles east of State Route 90 on State Route 82, west of  
Mile Post 56, ½ mile north. on Sagebrush Road  
T20S, R20E, Sec. 3

This is the address of the Cochise County Western Region Landfill. UVI is accessed through the landfill property.

**b.** The flight operations area authorized for the UA is depicted graphically below. This area shall be referred to as the Primary Containment Area (PCA). It is recognized that Raytheon may be permitted to operate within Special Use Airspace (SUA) per authorization

Vertical line of text or markings on the right side of the page.



10/28/2009

of the using agency. Under these circumstances, should the UA venture beyond the boundaries of the SUA (e.g. spill out), provisions of this experimental certificate shall apply, including authorization to only operate within the boundaries of the PCA. In these circumstances, Raytheon is responsible for notifying the FAA of the breach of any operations area.

c. The boundary of the Primary Containment Area is defined by the following coordinates:

- (1) N 31° 44' 00.00" W 110° 20' 30.00"
- (2) N 31° 52' 00.00" W 110° 20' 00.00"
- (3) N 31° 52' 00.00" W 110° 11' 00.00"
- (4) N 31° 56' 30.00" W 110° 11' 00.00"
- (5) N 31° 58' 10.00" W 110° 03' 00.00"
- (6) N 31° 50' 30.00" W 110° 03' 00.00"
- (7) N 31° 50' 30.00" W 110° 00' 00.00"
- (8) N 31° 45' 00.00" W 110° 00' 00.00"
- (9) N 31° 45' 00.00" W 110° 11' 00.00"
- (10) N 31° 43' 14.00" W 110° 14' 00.00"
- (11) N 31° 42' 00.00" W 110° 19' 30.00"
- (12) N 31° 44' 00.00" W 110° 19' 30.00"
- (13) Return to 1

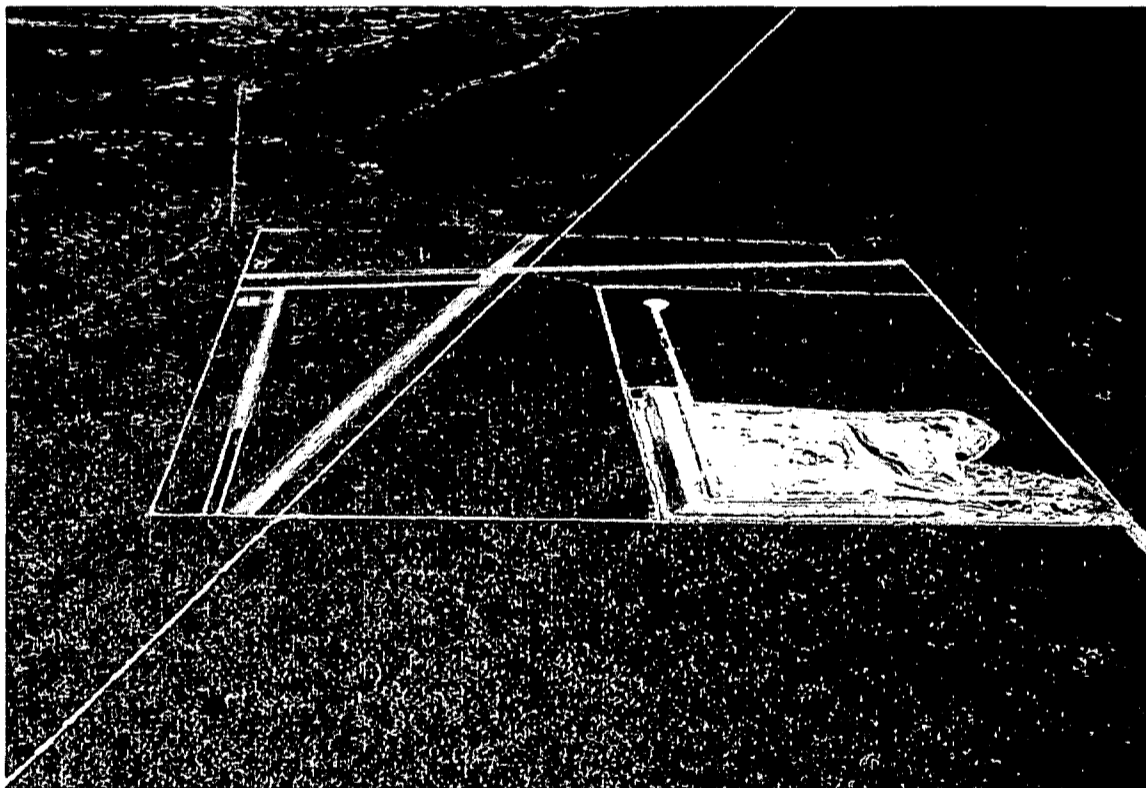
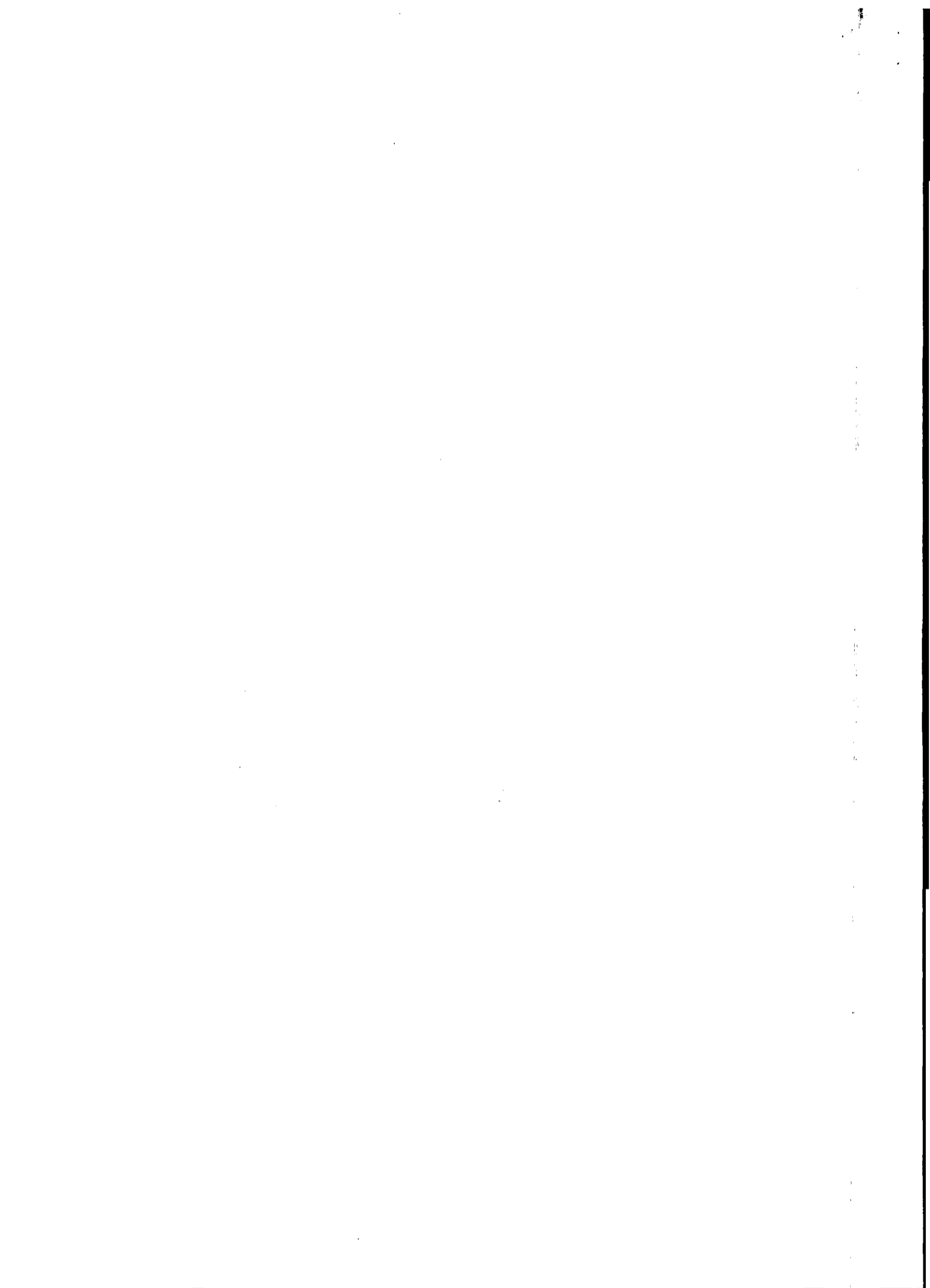

Figure 1. UVI UAS airfield looking north, located next to the Cochise County landfill.



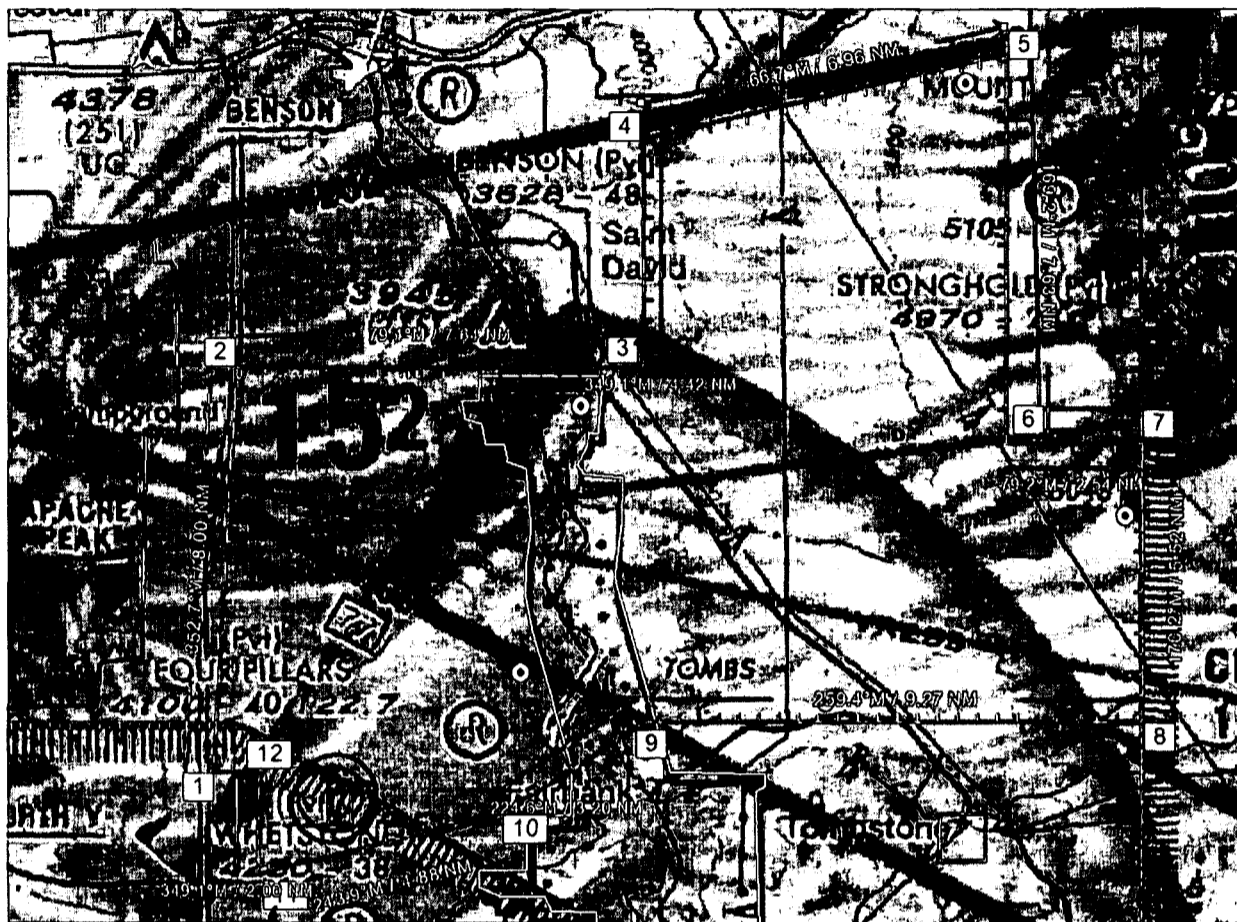

Figure 2. Phoenix Sectional, FHU 004/08.5, 4225' Elevation, N 31° 43' 30", W 110° 17' 47".

**d. Criteria for remaining in the flight test area.** The UAS PIC must ensure all UA flight operations remain within the lateral and vertical boundaries of the flight test area. **The maximum ceiling for all flight operations is 2000 ft AGL.** The UAS PIC must take into account all factors that may affect the capability of the UA to remain within the flight test area. This includes, but is not limited to, considerations for wind, gross weight, and glide distances.

**e. Incident/accident reporting.** Any incident/accident and any flight operation that transgresses the lateral or vertical boundaries of the flight test area or any restricted airspace must be reported to the FAA within 24 hours. This information must be reported to the Unmanned Aircraft Program Office (UAPO), AIR-160. AIR-160 can be reached by telephone at 202-385-4631 and fax at 202-385-4651. Accidents must be reported to the National Transportation Safety Board (NTSB) per instructions contained on the NTSB Web site: [www.ntsb.gov](http://www.ntsb.gov). Further flight operations must not be conducted until the incident is reviewed by AIR-160 and authorization to resume operations is provided to Raytheon Missile Systems.

## 5. UA Pilots and Observers.

### a. UA PIC roles and responsibilities.

- (1) The UA PIC must perform crew duties for only one UA at a time.
- (2) All flight operations must have a designated UA PIC. The UA PIC has responsibility over each flight conducted and is accountable for the UA flight operation.

Vertical line of text or markings on the right side of the page.

(3) The UA PIC is responsible for the safety of the UA as well as persons and property along the UA flight path. This includes, but is not limited to, collision avoidance and the safety of persons and property in the air and on the ground.

(4) The UA PIC must avoid densely populated areas (§ 91.319) and exercise increased vigilance when operating within or in the vicinity of published airway boundaries.

**b. UA PIC certification and ratings requirements.**

(1) The UA PIC must hold and be in possession of, at a minimum, an FAA private pilot certificate, with either an airplane, rotorcraft, or powered-lift category; and single- or multiengine class ratings, appropriate to the type of UA being operated.

(2) The UA PIC must have and be in possession of a valid second-class airman medical certificate issued under 14 CFR part 67, Medical Standards and Certification.

**c. UA PIC currency, flight review, and training.**

(1) No person may act as pilot in command of an unmanned aircraft unless that person has made at least three takeoffs and three landings in manned aircraft within the preceding 90 days acting as the sole manipulator of the flight controls.

(2) The UA PIC must have a flight review in manned aircraft every 24 calendar months in accordance with § 61.56, Flight review.

(3) The UA PIC must maintain currency in unmanned aircraft in accordance with Raytheon Missile Systems company procedures.

(4) The UA PIC must have a flight review in unmanned aircraft every 24 calendar months in accordance with Raytheon Missile Systems company procedures.

(5) All UA PICs must have successfully completed applicable Raytheon Missile Systems training for the UAS.

**d. Supplemental UA pilot roles and responsibilities.**

(1) Any additional UA pilot(s) assigned to a crew station during UA flight operations will be considered a supplemental UA pilot.

(2) A supplemental UA pilot assists the PIC in the operation of the UA and may do so at the same or a different control station as the PIC. The UA PIC will have operational override capability over any supplemental UA pilots, regardless of position.

(3) A supplemental UA pilot must perform crew duties for only one UA at a time.

**e. Supplemental UA pilot certification.**

(1) The supplemental UA PIC need not be a certificated pilot, but must have successfully completed a recognized private pilot ground school program.

(2) All supplemental pilots must have and be in possession of a valid second-class airman medical certificate issued under 14 CFR part 67, Medical Standards and Certification.

**f. Supplemental UA pilot currency, flight review, and training.**

(1) All UA pilots must maintain currency in unmanned aircraft in accordance with Raytheon Missile Systems company procedures.

(2) All UA pilots must have a flight review in unmanned aircraft every 24 calendar months in accordance with Raytheon Missile Systems company procedures.

12  
13  
14  
15  
16  
17  
18  
19  
20  
21  
22  
23  
24  
25  
26  
27  
28  
29  
30  
31  
32  
33  
34  
35  
36  
37  
38  
39  
40  
41  
42  
43  
44  
45  
46  
47  
48  
49  
50  
51  
52  
53  
54  
55  
56  
57  
58  
59  
60  
61  
62  
63  
64  
65  
66  
67  
68  
69  
70  
71  
72  
73  
74  
75  
76  
77  
78  
79  
80  
81  
82  
83  
84  
85  
86  
87  
88  
89  
90  
91  
92  
93  
94  
95  
96  
97  
98  
99  
100

(3) All UA pilots must have successfully completed applicable Raytheon Missile Systems training for the UAS.

**g. Observer roles and responsibilities.** The task of the observer is to provide the UA PIC(s) with instructions to maneuver the UA clear of any potential collision with other traffic. To satisfy these requirements:

(1) The observer must perform crew duties for only one UA at a time.

(2) At no time will the observer permit the UA to operate beyond the line-of-sight necessary to ensure maneuvering information can be reliably determined.

**(3) At no time will the observer conduct his/her duties more than one (1) nautical mile laterally or 2000 feet vertically from the UA.**

(4) An observer must maintain continuous visual contact with the UA to discern UA attitude and trajectory in relation to conflicting traffic.

(5) Observers must continually scan the airspace for other aircraft that pose a potential conflict.

(6) All flight operations conducted in the flight test area must have an observer to perform traffic avoidance and visual observation to fulfill the see-and-avoid requirement of § 91.113, Right-of-way rules: Except water operations.

**h. Observer certification.**

(1) All observers must either hold, at a minimum, an FAA private pilot license or must have successfully completed specific observer training acceptable to the FAA. An observer does not require currency as a pilot.

(2) All observers must have in their possession a valid second-class airman medical certificate issued under part 67.

**i. Observer training.**

(1) All observers must be thoroughly trained, be familiar with, and possess operational experience with the equipment being used. Such training is necessary for observation and detection of other aircraft for collision avoidance purposes as outlined in the Raytheon Missile Systems program letter.

(2) All observers must have successfully completed applicable Raytheon Missile Systems training for the UAS.

**6. Equipage.**

**a.** The UAS must be equipped with an operable transponder with Mode C or Mode S, and two-way communications equipment allowing communications between the UA pilot, observers, all UAS control stations, and ATC.

**b.** The UA and chase aircraft must be equipped with operable navigation, position, and/or strobe/anti-collision lights. Strobe/anti-collision lights must be illuminated during all operations.

**7. Communications.**

**a. Before UA flights.**

1  
2  
3  
4  
5  
6  
7  
8  
9  
10  
11  
12  
13  
14  
15  
16  
17  
18  
19  
20  
21  
22  
23  
24  
25  
26  
27  
28  
29  
30  
31  
32  
33  
34  
35  
36  
37  
38  
39  
40  
41  
42  
43  
44  
45  
46  
47  
48  
49  
50  
51  
52  
53  
54  
55  
56  
57  
58  
59  
60  
61  
62  
63  
64  
65  
66  
67  
68  
69  
70  
71  
72  
73  
74  
75  
76  
77  
78  
79  
80  
81  
82  
83  
84  
85  
86  
87  
88  
89  
90  
91  
92  
93  
94  
95  
96  
97  
98  
99  
100



(1) Before conducting operations, the frequency spectrum used for operation and control of the UA must be approved by the Federal Communications Commission or other appropriate government oversight agency.

(2) Raytheon shall contact Air Traffic Control prior to flight operations. Raytheon shall select and transmit transponder code 1200 unless otherwise directed by local Air Traffic Control. Upon initial contact with ATC, the UA PIC must indicate the experimental nature in accordance with § 91.319.

**b. During UA flights.**

(1) Appropriate air traffic frequencies must be monitored during flight operations.

(2) All UA positions must maintain two-way communications with each other during all operations. If unable to maintain two-way communication, the UA PIC will expeditiously return the UA to its base of operations while remaining within the flight test area and conclude the flight operation.

**8. Flight Conditions.**

**a. Daylight operations.** All flight operations must be conducted during daylight hours in visual meteorological conditions (VMC), including cloud clearance minimums as specified in § 91.155, Basic VFR weather minimums. Flight operation in instrument meteorological conditions (IMC) is not permitted.

**b. Prohibitions.**

(1) The UA is prohibited from aerobatic flight, that is, an intentional maneuver involving an abrupt change in the UA's attitude, an abnormal acceleration, or other flight action not necessary for normal flight. (See § 91.303, Aerobatic flight.)

(2) Flight operations must not involve carrying hazardous material or the dropping of any objects or external stores.

(3) No individual control station may be used to operate more than one UA at one time.

**c. Transponder requirements.** The UA must operate an approved operational Mode C or Mode S altitude encoding transponder during all flight operations.

**d. Transponder failure.** In the event of transponder failure, the UA must conclude all flight operations and expeditiously return to its base of operations within the prescribed limitations of this authorization.

**e. Notice to airman.** Raytheon Missile Systems must request the issuance of a Notice to Airman (NOTAM) through the appropriate FAA Automated Flight Service Station at least 24 hours before flight operation.

**9. Flight Termination and Lost Link Procedures.**

**a. Flight termination.** In accordance with Raytheon Missile Systems program letter, dated 09/30/2009, flight operations must be discontinued at any point that safe operation of the UA cannot be maintained or if hazard to persons or property is imminent.

**b. Lost link procedures.** In the event of lost link, the UA must provide a means of automatic recovery that ensures airborne operations are predictable and that the UA remains within the flight test area. The observer, all other UAS control stations, and the appropriate

Vertical text or markings along the right edge of the page, possibly a page number or header.

ATC facility will be immediately notified of the lost link condition and the expected UA response.

**10. Maintenance and Inspection.**

**a. General requirements.** The UAS must not be operated unless it is inspected and maintained in accordance with the FAA-approved Cobra UAS Inspection Program, dated 04/21/2008, or later approved FAA revision. Raytheon Missile Systems must establish and maintain aircraft maintenance records (see paragraph 10(d) below).

**b. Inspections.** No person may operate this UAS unless within the preceding 12 calendar months unless it has had a condition inspection performed according to the Cobra UAS Inspection Program, dated 04/21/2008. The UAS must also have been found to be in a condition for safe operation. This inspection will be recorded in the UAS maintenance records as described in paragraph 10(d) below.

**c. Authorized inspectors.** Only those individuals trained and authorized by Raytheon Missile Systems and acceptable to the FAA may perform the inspections and maintenance required by these operating limitations.

**d. Maintenance and inspection records.** Maintenance and inspections of the UAS must be recorded in the UAS maintenance records. The following information must be recorded:

(1) Maintenance record entries must include a description of the work performed, the date of completion for the work, the UAS's total time-in-service, and the name and signature of the person performing the work.

(2) Inspection entries must contain the following, or a similarly worded, statement: *I certify that this UAS was inspected on (date), in accordance with the scope and detail of the Raytheon Missile Systems Cobra UAS Inspection Program, and was found to be in a condition for safe operation.*

(3) UAS instruments and equipment required to be installed must be inspected and maintained in accordance with the requirements of the Raytheon Missile Systems Cobra UAS Inspection Program. Any maintenance or inspection of this equipment must be recorded in the UAS maintenance records.

(4) No person may operate this UAS unless the altimeter system and transponder have been tested within the preceding 24 calendar months in accordance with § 91.413, ATC transponder tests and inspections. These inspections will be recorded in the UAS maintenance records.

**11. Information Reporting.** Raytheon Missile Systems will provide the following information on a monthly basis, via email, to Mr. Donald Grampp of the FAA UAPO. Mr. Grampp's email address is [donald.e.grampp@faa.gov](mailto:donald.e.grampp@faa.gov). A copy of the report shall be provided to AIR-200.

- a. Number of flights conducted under this certificate.
- b. Pilot duty time per flight.
- c. Unusual equipment malfunctions (hardware or software).
- d. Deviations from ATC instructions.
- e. Unintended entry into lost link flight mode that results in a course change.

**12. Revisions and Other Provisions.**



10/28/2009

**a. Experimental certificates, program letters, and operating limitations.** The experimental certificate, FAA-accepted Raytheon Missile Systems program letter, and operating limitations cannot be reissued, renewed, or revised without application being made to the Van Nuys Manufacturing Inspection District (MIDO), in coordination with AIR-200. AIR-200 will be responsible for FAA Headquarters internal coordination with the Aircraft Certification Service, Flight Standards Service, Air Traffic Organization, Office of the Chief Council, and Office of Rulemaking.

**b. Certificates of waiver or authorization.** The Production and Airworthiness Division, AIR-200 and the Van Nuys MIDO shall be notified immediately if there is any plan for requesting a Certificate of Authorization or Waiver (COA) for UAS operations during the time period the Experimental Certificate is in effect. If the aircraft is authorized to operate under a COA, Raytheon must determine that the aircraft is in a condition for safe operation and appropriately configured for the purpose intended. A record entry will be made by an appropriately rated person to document that finding in the aircraft logbook.

**c. Amendments and cancellations.** The provisions and limitations annotated in this operational approval may be amended or cancelled at any time as deemed necessary by the FAA.

**d. Reviews of revisions.** All revisions to Raytheon Missile Systems FAA-approved Inspection Program must be reviewed and accepted by the Scottsdale Flight Standards District Office.

### **13. UAS Modifications.**

**a. Software and system changes.** All software and system changes will be documented as part of the normal maintenance procedures and will be available for inspection. All software and system changes must be inspected and approved per FAA-approved Cobra UAS Inspection Program, dated 04/21/2008. All software changes to the aircraft and control station are categorized as major changes, and must be provided to AIR-200 in summary form at the time they are incorporated.

**b. Major modifications.** All major modifications, whether performed under the experimental certificate, COA, or other authorizations, that could potentially affect the safe operation of the system, must be documented and provided to the AIR-200 before operating the aircraft under this certificate. Major modifications incorporated under COA or other authorizations need to be provided only if the aircraft is flown under these authorizations during the effective period of the experimental certificate.

End of Limitations

9  
10  
11  
12  
13  
14  
15  
16  
17  
18  
19  
20  
21  
22  
23  
24  
25  
26  
27  
28  
29  
30  
31  
32  
33  
34  
35  
36  
37  
38  
39  
40  
41  
42  
43  
44  
45  
46  
47  
48  
49  
50  
51  
52  
53  
54  
55  
56  
57  
58  
59  
60  
61  
62  
63  
64  
65  
66  
67  
68  
69  
70  
71  
72  
73  
74  
75  
76  
77  
78  
79  
80  
81  
82  
83  
84  
85  
86  
87  
88  
89  
90  
91  
92  
93  
94  
95  
96  
97  
98  
99  
100

10/28/2009

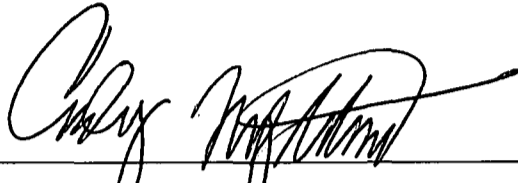

Cindy Napolitano  
Aviation Safety Inspector  
Van Nuys Manufacturing Inspection District Office  
7120 Hayvenhurst Ave, Suite 100  
Van Nuys, CA 91406

Date: 10/28/2009

**The Special Airworthiness Certificate and accompanying Operating Limitations expire on October 28, 2010.**

**I certify that I have read and understand the operating limitations, and conditions, that are a part of the Special Airworthiness Certificate; FAA Form 8130-7 issued on October 28, 2009 for the purpose of Research and Development, Market Survey, and/or Crew Training.**

**This Special Airworthiness Certificate is issued for the Raytheon Missile Systems, UA model "Cobra," serial number 006, registration number N606RN.**



**Applicant:**

**Date:** October 28, 2009

**Name:** Donald L. Newman  
**Title:** Director Unmanned Systems  
**Company:** Raytheon Missile Systems





FAA FORM 8130-6, APPLICATION FOR U.S. AIRWORTHINESS CERTIFICATE

Form Approved O.M.B. No. 2120-0018  
09/30/2007

Accepted KA Dec/16/2008

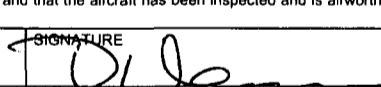
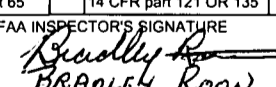
U.S. Department of Transportation Federal Aviation Administration		APPLICATION FOR U.S. AIRWORTHINESS CERTIFICATE		INSTRUCTIONS - Print or type. Do not write in shaded areas; these are for FAA use only. Submit original only to an authorized FAA Representative. If additional space is required, use attachment. For special flight permits complete Sections II, VI and VII as applicable.		
I. AIRCRAFT DESIGNATION	1. REGISTRATION MARK	2. AIRCRAFT BUILDER'S NAME (Make)	3. AIRCRAFT MODEL DESIGNATION	4. YR. MFR.	FAA CODING	
	N606RN	Raytheon	Cobra	2006		
	5. AIRCRAFT SERIAL NO.	6. ENGINE BUILDER'S NAME (Make)	7. ENGINE MODEL DESIGNATION			
	006	Desert Aircraft	DA-150			
	8. NUMBER OF ENGINES	9. PROPELLER BUILDER'S NAME (Make)	10. PROPELLER MODEL DESIGNATION		11. AIRCRAFT IS (Check if applicable)	
	1	Mezjlick	28 x 12-3B		IMPORT	
APPLICATION IS HEREBY MADE FOR: (Check applicable items)						
A	1	STANDARD AIRWORTHINESS CERTIFICATE (Indicate Category)		NORMAL	UTILITY	
B	1	SPECIAL AIRWORTHINESS CERTIFICATE (Check appropriate items)		UNMANNED AIRCRAFT		
II. CERTIFICATION REQUESTED	7	PRIMARY				
	9	LIGHT-SPORT (Indicate Class)	AIRPLANE	POWER-PARACHUTE	WEIGHT-SHIFT-CONTROL	
	2	LIMITED				
	5	PROVISIONAL (Indicate Class)	1	CLASS I		
			2	CLASS II		
	3	RESTRICTED (Indicate operation(s) to be conducted)	1	AGRICULTURE AND PEST CONTROL	2	AERIAL SURVEY
			4	FOREST (Wildlife Conservation)	5	PATROLLING
			0	OTHER (Specify)		
	4	EXPERIMENTAL (Indicate operation(s) to be conducted)	1	RESEARCH AND DEVELOPMENT	2	AMATEUR BUILT
			4	AIR RACING	5	CREW TRAINING
0			TO SHOW COMPLIANCE WITH THE CFR			
7			OPERATING (Primary Category) KIT BUILT AIRCRAFT			
8	SPECIAL FLIGHT PERMIT (Indicate operation(s) to be conducted, then complete Section VI or VII as applicable on reverse side)	8A	Existing Aircraft without an airworthiness certificate & do not meet § 103.1			
		8B	Operating Light-Sport Kit-Built			
		8C	Operating light-sport previously issued special light-sport category airworthiness certificate under § 21.190			
		1	FERRY FLIGHT FOR REPAIRS, ALTERATIONS, MAINTENANCE, OR STORAGE			
		2	EVACUATION FROM AREA OF IMPENDING DANGER			
		3	OPERATION IN EXCESS OF MAXIMUM CERTIFICATED TAKE-OFF WEIGHT			
		4	DELIVERING OR EXPORTING	5	PRODUCTION FLIGHT TESTING	
		6	CUSTOMER DEMONSTRATION FLIGHTS			
C	6	MULTIPLE AIRWORTHINESS CERTIFICATE (check ABOVE "Restricted Operation" and "Standard" or "Limited" as applicable)				
III. OWNER'S CERTIFICATION	A. REGISTERED OWNER (As shown on certificate of aircraft registration)		IF DEALER, CHECK HERE			
	NAME Raytheon Co		ADDRESS PO Box 11337 Tucson, AZ 85734-1337			
	B. AIRCRAFT CERTIFICATION BASIS (Check applicable blocks and complete items as indicated)					
	AIRCRAFT SPECIFICATION OR TYPE CERTIFICATE DATA SHEET (Give No. and Revision No.) NA		AIRCRAFT LISTING (Give page number(s)) NA			
C. AIRCRAFT OPERATION AND MAINTENANCE RECORDS						
	CHECK IF RECORDS IN COMPLIANCE WITH 14 CFR Section 91.417	TOTAL AIRFRAME HOURS 0.3	3	EXPERIMENTAL ONLY (Enter hours flown since last certificate issued or renewed) 0.3		
D. CERTIFICATION - I hereby certify that I am the registered owner (or his agent) of the aircraft described above, that the aircraft is registered with the Federal Aviation Administration in accordance with Title 49 of the United States Code 44101 et seq. and applicable Federal Aviation Regulations, and that the aircraft has been inspected and is airworthy and eligible for the airworthiness certificate requested.						
DATE OF APPLICATION 102408		NAME AND TITLE (Print or type) Donald L. Newman, Director, Unmanned Systems		SIGNATURE 		
IV. INSPECTION AGENCY VERIFICATION	A. THE AIRCRAFT DESCRIBED ABOVE HAS BEEN INSPECTED AND FOUND AIRWORTHY BY: (Complete the section only if 14 CFR part 21.183(d) applies.)					
	2	14 CFR part 121 CERTIFICATE HOLDER (Give Certificate No.)	3	CERTIFICATED MECHANIC (Give Certificate No.)	6	
	5	AIRCRAFT MANUFACTURER (Give name or firm)				
	DATE	TITLE	SIGNATURE			
V. FAA REPRESENTATIVE CERTIFICATION	(Check ALL applicable block items A and B)					
	A. I find that the aircraft described in Section I or VII meets requirements for		THE CERTIFICATE REQUESTED			
	B. Inspection for a special permit under Section VII was conducted by:		AMENDMENT OR MODIFICATION OF CURRENT AIRWORTHINESS CERTIFICATE			
			FAA INSPECTOR	FAA DESIGNEE		
		CERTIFICATE HOLDER UNDER	14 CFR part 65	14 CFR part 121 OR 135	14 CFR part 145	
DATE	DISTRICT OFFICE	DESIGNEE'S SIGNATURE AND NO.		FAA INSPECTOR'S SIGNATURE		
10/24/2008	PHOENIX M100 NH-50	4		1  BRADLEY ROON		

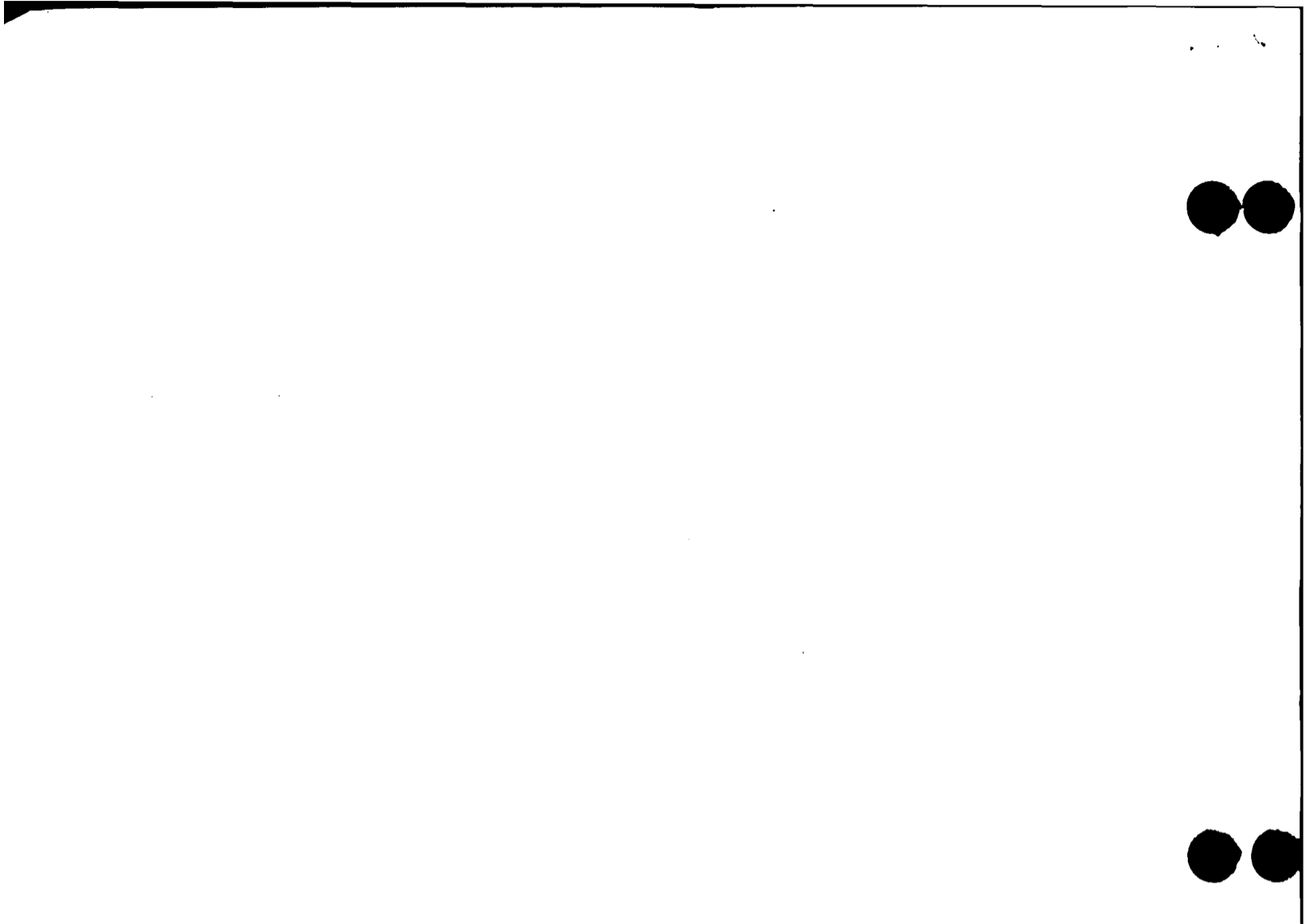

VI. PRODUCTION FLIGHT TESTING	A. MANUFACTURER				
	NAME		ADDRESS		
	B. PRODUCTION BASIS <i>(Check applicable item)</i>				
	<input type="checkbox"/>	PRODUCTION CERTIFICATE <i>(Give production certificate number)</i> →			
	<input type="checkbox"/>	TYPE CERTIFICATE ONLY			
	<input type="checkbox"/>	APPROVED PRODUCTION INSPECTION SYSTEM			
	C. GIVE QUANTITY OF CERTIFICATES REQUIRED FOR OPERATING NEEDS				
	DATE OF APPLICATION		NAME AND TITLE <i>(Print or Type)</i>	SIGNATURE	
	VII. SPECIAL FLIGHT PERMIT PURPOSES OTHER THAN PRODUCTION FLIGHT TEST	A. DESCRIPTION OF AIRCRAFT			
REGISTERED OWNER		ADDRESS			
BUILDER <i>(Make)</i>		MODEL			
SERIAL NUMBER		REGISTRATION MARK			
B. DESCRIPTION OF FLIGHT					
FROM		TO	CUSTOMER DEMONSTRATION FLIGHTS <input type="checkbox"/> <i>(Check if applicable)</i>		
VIA		DEPARTURE DATE	DURATION		
C. CREW REQUIRED TO OPERATE THE AIRCRAFT AND ITS EQUIPMENT					
<input type="checkbox"/>		PILOT	<input type="checkbox"/>	CO-PILOT	<input type="checkbox"/>
<input type="checkbox"/>			<input type="checkbox"/>	FLIGHT ENGINEER	<input type="checkbox"/>
<input type="checkbox"/>		<input type="checkbox"/>	OTHER <i>(Specify)</i>		
D. THE AIRCRAFT DOES NOT MEET THE APPLICABLE AIRWORTHINESS REQUIREMENTS AS FOLLOWS:					
E. THE FOLLOWING RESTRICTIONS ARE CONSIDERED NECESSARY FOR SAFE OPERATION: <i>(Use attachment if necessary)</i>					
F. CERTIFICATION – I hereby certify that I am the registered owner (or his agent) of the aircraft described above; that the aircraft is registered with the Federal Aviation Administration in accordance with Title 49 of the United States Code 44101 <u>et seq.</u> , and applicable Federal Aviation Regulations; and that the aircraft has been inspected and is safe for the flight described.					
DATE		NAME AND TITLE <i>(Print or Type)</i>	SIGNATURE		
VIII. AIRWORTHINESS DOCUMENTATION (FAA/DESIGNEE use only)	<input checked="" type="checkbox"/>	A. Operating Limitations and Markings in Compliance with 14 CFR Section 91.9, as applicable.		G. Statement of Conformity, FAA Form 8130-9 <i>(Attach when required)</i>	
	<input checked="" type="checkbox"/>	B. Current Operating Limitations Attached		H. Foreign Airworthiness Certification for Import Aircraft <i>(Attach when required)</i>	
	<input checked="" type="checkbox"/>	C. Data, Drawings, Photographs, etc. <i>(Attach when required)</i>		I. Previous Airworthiness Certificate Issued in Accordance with 14 CFR Section <u>21.191(a)(c) &amp; (d)</u> <i>(Original Attached)</i>	
	<input checked="" type="checkbox"/>	D. Current Weight and Balance information Available in Aircraft		<input checked="" type="checkbox"/>	
	<input type="checkbox"/>	E. Major Repair and Alteration, FAA Form 337 <i>(Attach when required)</i>		<input checked="" type="checkbox"/>	
	<input checked="" type="checkbox"/>	F. This inspection Recorded in Aircraft Records		J. Current Airworthiness Certificate Issued in Accordance with 14 CFR Section <u>21.191(a)(c) &amp; (d)</u> <i>(Copy Attached)</i>	
			K. Light-Sport Aircraft Statement of Compliance, FAA Form 8130-15 <i>(Attach when required)</i>		

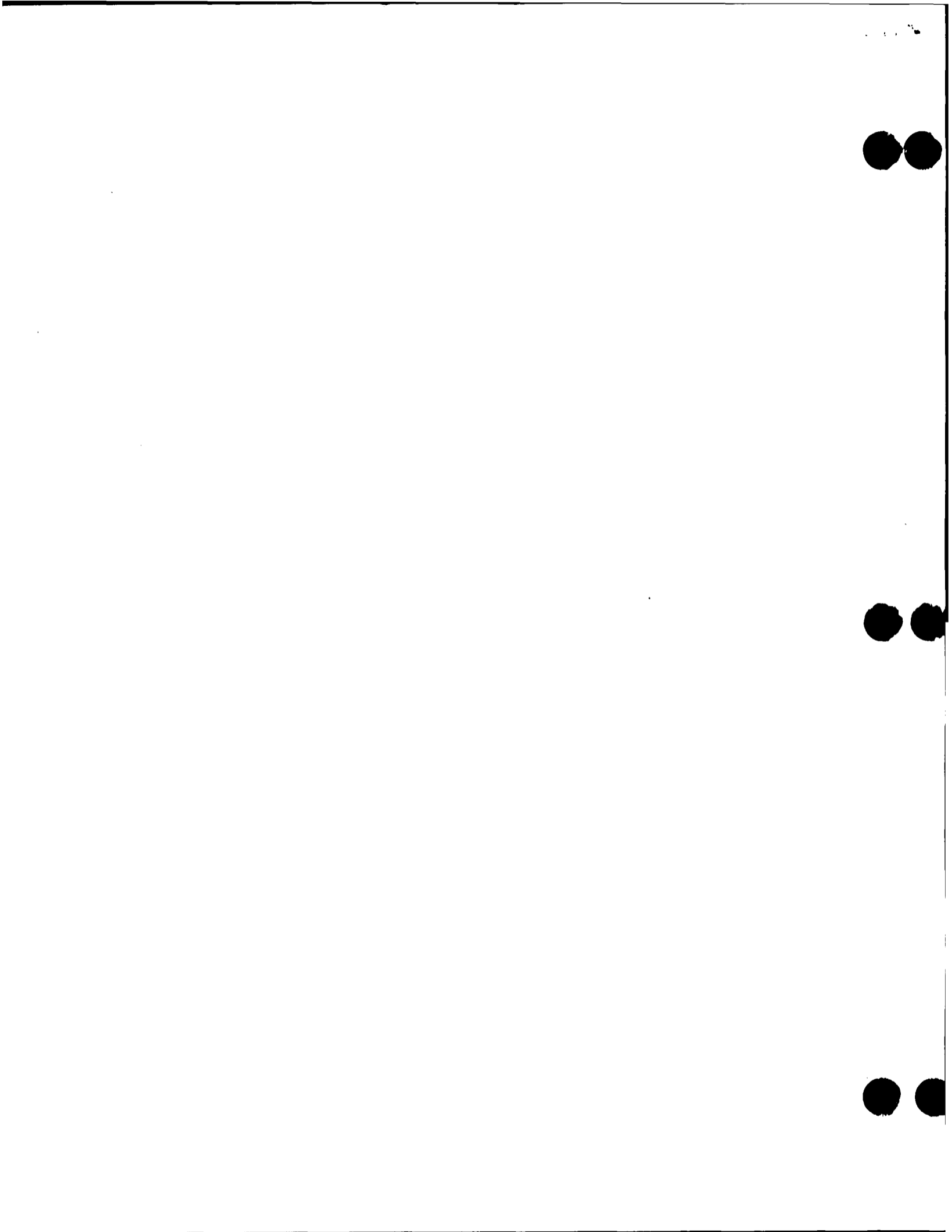

UNITED STATES OF AMERICA  
DEPARTMENT OF TRANSPORTATION - FEDERAL AVIATION ADMINISTRATION  
**SPECIAL AIRWORTHINESS CERTIFICATE**

<b>A</b>	CATEGORY/DESIGNATION	Experimental (Unmanned Aircraft)		
	PURPOSE	Research and Development, Crew Training, and/or Market Survey		
<b>B</b>	MANUFACTURER	NAME	N/A	
		ADDRESS	N/A	
<b>C</b>	FLIGHT	FROM	N/A	
		TO	N/A	
<b>D</b>	N- 606RN	SERIAL NO.	006	
	BUILDER Raytheon Company	MODEL	Cobra	
	DATE OF ISSUANCE	October 24, 2008	EXPIRY	October 24, 2009
	OPERATING LIMITATIONS DATED	10/24/08	(ARE PART OF THIS CERTIFICATE)	
<b>E</b>	SIGNATURE OF FAA REPRESENTATIVE	DESIGNATION OR OFFICE NO.		
	<i>Bradley Rooh</i> Bradley Rooh	Phoenix MIDO NM-50		

Any alteration, reproduction or misuse of this certificate may be punishable by a fine not exceeding \$1,000 or imprisonment not exceeding 3 years, or both. THIS CERTIFICATE MUST BE DISPLAYED IN THE AIRCRAFT IN ACCORDANCE WITH APPLICABLE TITLE 14, CODE OF FEDERAL REGULATIONS (CFR).

FAA Form 8130-7 (07/04) SEE REVERSE SIDE NSN: 0052-00-693-4000

---

<b>A</b>	This airworthiness certificate is issued under the authority of Public Law 104-6, 49 United States Code (USC) 44704 and Title 14 Code of Federal Regulations (CFR).
<b>B</b>	The airworthiness certificate authorizes the manufacturer named on the reverse side to conduct production flight tests, and only production flight tests, of aircraft registered in his name. No person may conduct production flight tests under this certificate: (1) Carrying persons or property for compensation or hire; and/or (2) Carrying persons not essential to the purpose of the flight.
<b>C</b>	This airworthiness certificate authorizes the flight specified on the reverse side for the purpose shown in Block A.
<b>D</b>	This airworthiness certificate certifies that as of the date of issuance, the aircraft to which issued has been inspected and found to meet the requirements of the applicable CFR. The aircraft does not meet the requirements of the applicable comprehensive and detailed airworthiness code as provided by Annex 8 to the Convention On International Civil Aviation. No person may operate the aircraft described on the reverse side: (1) except in accordance with the applicable CFR and in accordance with conditions and limitations which may be prescribed by the Administrator as part of this certificate; (2) over any foreign country without the special permission of that country.
<b>E</b>	Unless sooner surrendered, suspended, or revoked, this airworthiness certificate is effective for the duration and under the conditions prescribed in 14 CFR, Part 21, Section 21.181 or 21.217.

---

UNITED STATES OF AMERICA  
 DEPARTMENT OF TRANSPORTATION - FEDERAL AVIATION ADMINISTRATION  
**SPECIAL AIRWORTHINESS CERTIFICATE**

<b>A</b>	CATEGORY/DESIGNATION	Experimental (Unmanned Aircraft)	
	PURPOSE	Research and Development, Crew Training, and/or Market Survey	
<b>B</b>	MANUFACTURER	NAME	N/A
		ADDRESS	N/A
<b>C</b>	FLIGHT	FROM	N/A
		TO	N/A
<b>D</b>	N- 606RN	★	SERIAL NO. 006
	BUILDER	Ratheon Company	MODEL Cobra
	DATE OF ISSUANCE	October 26, 2007	EXPIRY October 25, 2008
	OPERATING LIMITATIONS DATED	10/26/07	(ARE PART OF THIS CERTIFICATE
<b>E</b>	SIGNATURE OF FAA REPRESENTATIVE	DESIGNATION OR OFFICE NO.	
		Phoenix MIDO NM-50	

Any alteration, reproduction or misuse of this certificate may be punishable by a fine not exceeding \$1,000 or imprisonment not exceeding 3 years, or both. THIS CERTIFICATE MUST BE DISPLAYED IN THE AIRCRAFT IN ACCORDANCE WITH APPLICABLE TITLE 14, CODE OF FEDERAL REGULATIONS (CFR).

<b>A</b>	This airworthiness certificate is issued under the authority of Public Law 104-6, 49 United States Code (USC) 44704 and Title 14 Code of Federal Regulations (CFR).
<b>B</b>	The airworthiness certificate authorizes the manufacturer named on the reverse side to conduct production flight tests, and only production flight tests, of aircraft registered in his name. No person may conduct production flight tests under this certificate: (1) Carrying persons or property for compensation or hire; and/or (2) Carrying persons not essential to the purpose of the flight.
<b>C</b>	This airworthiness certificate authorizes the flight specified on the reverse side for the purpose shown in Block A.
<b>D</b>	This airworthiness certificate certifies that as of the date of issuance, the aircraft to which issued has been inspected and found to meet the requirements of the applicable CFR. The aircraft does not meet the requirements of the applicable comprehensive and detailed airworthiness code as provided by Annex 8 to the Convention On International Civil Aviation. No person may operate the aircraft described on the reverse side: (1) except in accordance with the applicable CFR and in accordance with conditions and limitations which may be prescribed by the Administrator as part of this certificate; (2) over any foreign country without the special permission of that country.
<b>E</b>	Unless sooner surrendered, suspended, or revoked, this airworthiness certificate is effective for the duration and under the conditions prescribed in 14 CFR, Part 21, Section 21.181 or 21.217.



October 24, 2008



Phoenix Manufacturing Inspection District Office  
13951 North Scottsdale Road, Suite 123  
Scottsdale, AZ 85254

### Operating Limitations

#### Experimental: Research and Development, Market Survey, and/or Crew Training

<b>Registered Owner Name:</b> Raytheon Missile Systems	<b>Aircraft Builder:</b> Raytheon Missile Systems Bldg M09, M/S 5 P.O. Box 11337 Tucson, AZ 85734-1337
<b>Registered Owner Address:</b> Bldg M09, M/S 5 P.O. Box 11337 Tucson, AZ 85734-1337	<b>Year Manufactured:</b> 2006
<b>Aircraft Description:</b> Unmanned, composite, mid-wing monoplane with standard tail surfaces and a tractor engine.	<b>Aircraft Serial Number:</b> 006
<b>Aircraft Registration:</b> N606RN	<b>Aircraft Model Designation:</b> Cobra
	<b>Engine Model:</b> Desert Aircraft DA-150

The following conditions and limitations apply to all unmanned aircraft system (UAS) flight operations for the Raytheon Cobra while operating in the National Airspace System (NAS).

#### 1. General Information.

a. **Integrated system.** For the purposes of this special airworthiness certificate and operating limitations, the Raytheon Cobra operated by Raytheon Missile Systems is considered to be an integrated system. The system is composed of the following:

- (1) Raytheon Missile Systems, Cobra, unmanned aircraft, s/n 006,
- (2) UAS control stations, fixed, mobile, or ground-based,
- (3) Telemetry, launch, and recovery equipment,
- (4) Communications and navigation equipment, including ground and/or airborne equipment used for command and control of the Raytheon Cobra.
- (5) Equipment on the ground and in the air used for communication with other members of the flightcrew, observers, air traffic control (ATC), and other users of the NAS.

\_\_\_\_\_

October 24, 2008

**b. Compliance with 14 CFR part 61 (Certification: Pilots, Flight Instructors, and Ground Instructors) and part 91 (General Operating and Flight Rules).** Unless otherwise specified in this document, the UA pilot-in-command (PIC) and Raytheon Missile Systems must comply with all applicable sections and parts of 14 CFR including, but not limited to, parts 61 and 91.

**c. Operational requirements.**

(1) No person may operate this UAS for other than the purpose of research and development, market survey, and/or crew training, to accomplish the flight operation outlined in Raytheon Missile Systems program letter dated 09/30/2008, which describes compliance with § 21.193(d), Experimental certificates: General, and has been made available to the UA PIC.

(2) This UAS must be operated in accordance with applicable air traffic and general operating rules of part 91 and all additional limitations herein prescribed under the provisions of § 91.319(i), Aircraft having experimental certificates: Operating limitations.

(3) Raytheon Missile Systems must accumulate at least 50 flight hours under its experimental airworthiness certificate before customer crew training is permitted, in accordance with § 21.195(d), Experimental certificates: Aircraft to be used for market surveys, sales demonstrations, and customer crew training.

**d. UA condition.** The UA PIC must determine that the UA is in a condition for safe operation and in a configuration appropriate for the purpose of the intended flight.

**e. Multiple-purpose operations.** When changing between operating purposes of a multiple purpose certificate, the operator must determine that the aircraft is in a condition for safe operation and appropriate for the purpose intended. A record entry will be made by an appropriately rated person (that is, an individual authorized by the applicant and acceptable to the FAA) to document that finding in the aircraft maintenance records.

**f. Operation exceptions.** No person may operate this UA to carry property for compensation or hire (§ 91.319(a)(2)).

**g. UA markings.**

(1) This UA must be marked with its U.S. registration number in accordance with part 45 or alternative marking approval issued by the FAA Production and Airworthiness Division (AIR-200).

(2) This UA must display the word *Experimental* in accordance with § 45.23(b), Display of marks, unless otherwise granted an exemption from this requirement.

**h. Required documentation.** Before conducting the initial flight of the Cobra UAS, Raytheon Missile Systems must transmit by email a scanned copy of the Raytheon Cobra program letter, special airworthiness certificate, and operating limitations to the following FAA personnel:

(1) Debra Trindle, FAA Air Traffic Representative, Luke and Davis-Monthan Air Force Base, AZ, (623) 856-9596, email: [debra.trindle@faa.gov](mailto:debra.trindle@faa.gov).

(2) Roger Trevino, System Support Specialist, FAA Central Service Area, System Support Group, AJO2-C2, (817)-222-5595, email: [roger.trevino@faa.gov](mailto:roger.trevino@faa.gov)

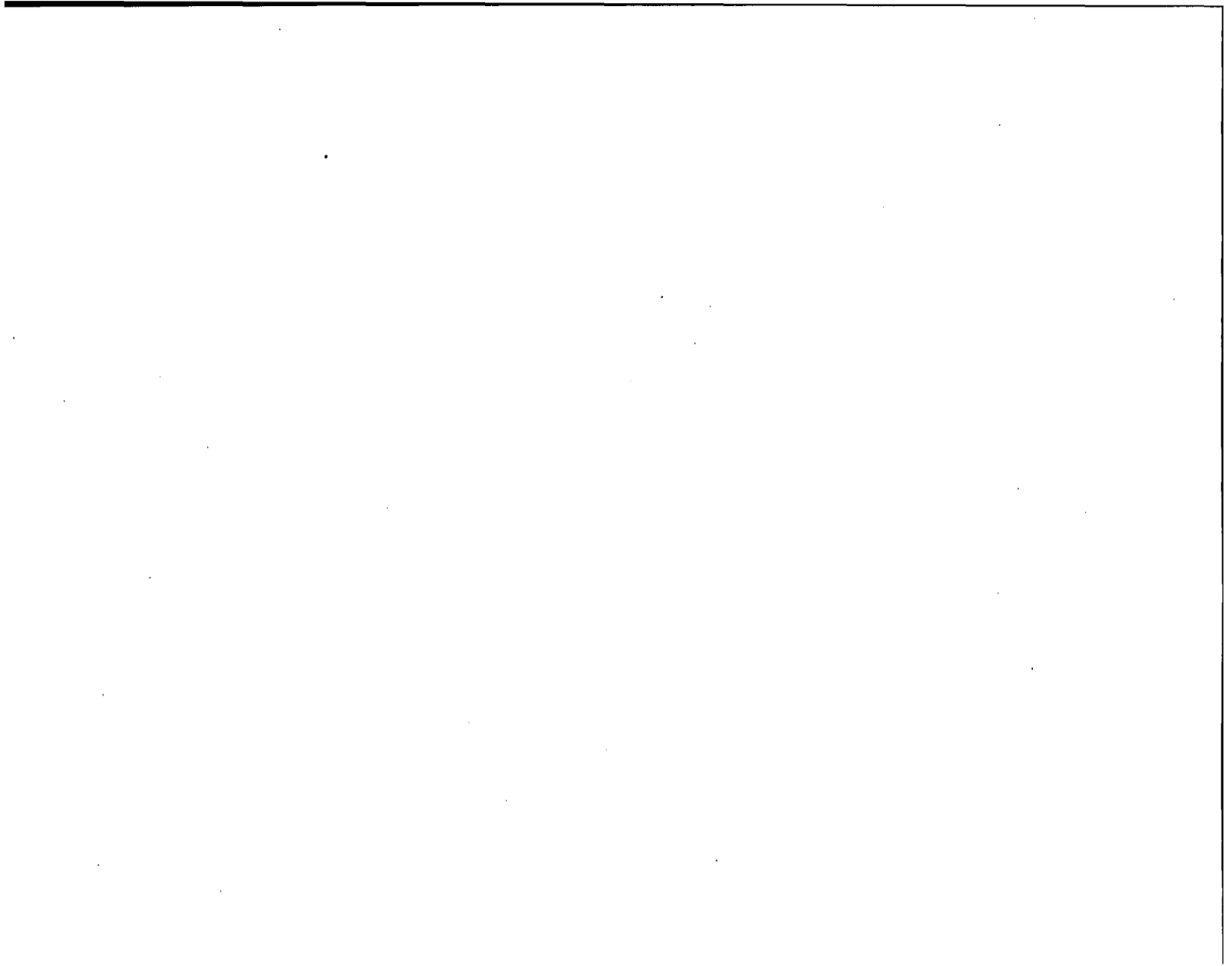

October 24, 2008

(3) Dennis W. Bee Jr., Air Traffic Representative, Southern Nevada, Utah, & Colorado Air Traffic Representative, AJO2-W2, (702) 652-5530, email: [dennis.bee@faa.gov](mailto:dennis.bee@faa.gov).

(4) Richard Posey, Aviation Safety Inspector, Production and Airworthiness Division, AIR-200, (202) 267-9538, email: [richard.posey@faa.gov](mailto:richard.posey@faa.gov).

**i. Change in registrant address.** Section 47.45, Change of address, requires that the FAA Aircraft Registry be notified within 30 days of any change in the aircraft registrant's address. Such notification is to be made by providing AC Form 8050-1, Aircraft Registration Application, to the FAA Aircraft Registration Branch (AFS-750) in Oklahoma City, Oklahoma.

**j. Certificate display and manual availability.** The airworthiness and registration certificates must be displayed, and the aircraft flight manual must be available to the pilot, as prescribed by the applicable sections of 14 CFR, or as prescribed by an exemption granted to Raytheon Missile Systems, in accordance with 14 CFR part 11, General Rulemaking Procedures.

**2. Program Letter.** The Raytheon Cobra program letter, dated 09/30/2008, will be used as a basis for determining the operating limitations prescribed in this document. All flight operations must be conducted in accordance with the provisions of this document.

### **3. Initial Flight Testing.**

**a. Requirements.** Flight operations must be conducted within visual line of sight of the pilot/observer. Initial flight testing must be completed upon accumulation of 25 flight hours. Following satisfactory completion of initial flight testing, the operations manager or chief pilot must certify in the records that the aircraft has been shown to comply with § 91.319(b). Compliance with § 91.319(b) must be recorded in the aircraft records with the following, or a similarly worded, statement:

*I certify that the prescribed flight test hours have been completed and the aircraft is controllable throughout its normal range of speeds and throughout all maneuvers to be executed, has no hazardous operating characteristics or design features, and is safe for operation. The following aircraft operating data has been demonstrated during the flight testing: speeds V<sub>x</sub> \_\_\_\_\_, and V<sub>y</sub> \_\_\_\_\_, and the weight \_\_\_\_\_ and CG location \_\_\_\_\_ at which they were obtained.*

**b. Aircraft operations for the purpose of market surveys, sales demonstrations, and customer crew training.** These operations cannot be performed until 50 flight hours have been accomplished. An entry in the aircraft maintenance records is required as evidence of compliance.

**4. Authorized Flight Operations Area.** Two flight operations areas are authorized for the purpose of this certificate. **The maximum ceiling for all flight operations is 2000 ft AGL.**

**a.** The main base of operations for the UA shall be:

Unmanned Vehicles International, Inc  
2595 North Sagebrush Road, Whetstone, AZ  
±4 Miles east of State Route 90 on State Route 82, west of  
Mile Post 56, ½ mile north. on Sagebrush Road  
T20S, R20E, Sec. 3

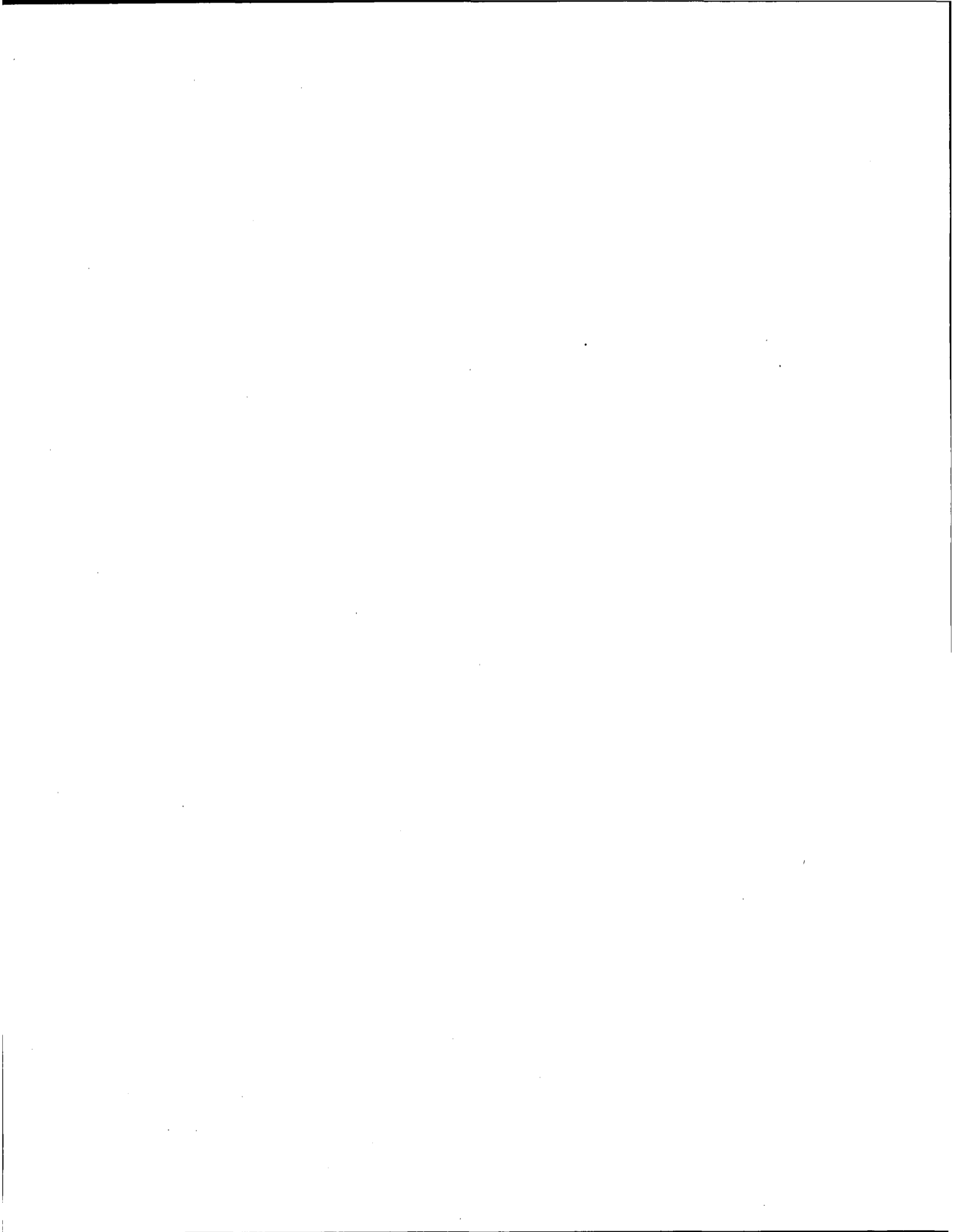

October 24, 2008

This is the address of the Cochise County Western Region Landfill. UVI is accessed through the landfill property.

b. The flight operations area authorized for the UA is depicted graphically below. This area shall be referred to as the Primary Containment Area (PCA). It is recognized that Raytheon may be permitted to operate within Special Use Airspace (SUA) per authorization of the using agency. Under these circumstances, should the UA venture beyond the boundaries of the SUA (e.g. spill out), provisions of this experimental certificate shall apply, including authorization to only operate within the boundaries of the PCA. In these circumstances, Raytheon is responsible for notifying the FAA of the breach of any operations area.

c. The boundary of the Primary Containment Area is defined by the following coordinates:

- 1) N 31° 44' 00.00" W 110° 20' 30.00"
- 2) N 31° 52' 00.00" W 110° 20' 00.00"
- 3) N 31° 52' 00.00" W 110° 11' 00.00"
- 4) N 31° 56' 30.00" W 110° 11' 00.00"
- 5) N 31° 58' 10.00" W 110° 03' 00.00"
- 6) N 31° 50' 30.00" W 110° 03' 00.00"
- 7) N 31° 50' 30.00" W 110° 00' 00.00"
- 8) N 31° 45' 00.00" W 110° 00' 00.00"
- 9) N 31° 45' 00.00" W 110° 11' 00.00"
- 10) N 31° 43' 14.00" W 110° 14' 00.00"
- 11) N 31° 42' 00.00" W 110° 19' 30.00"
- 12) N 31° 44' 00.00" W 110° 19' 30.00"
- 13) Return to 1





October 24, 2008

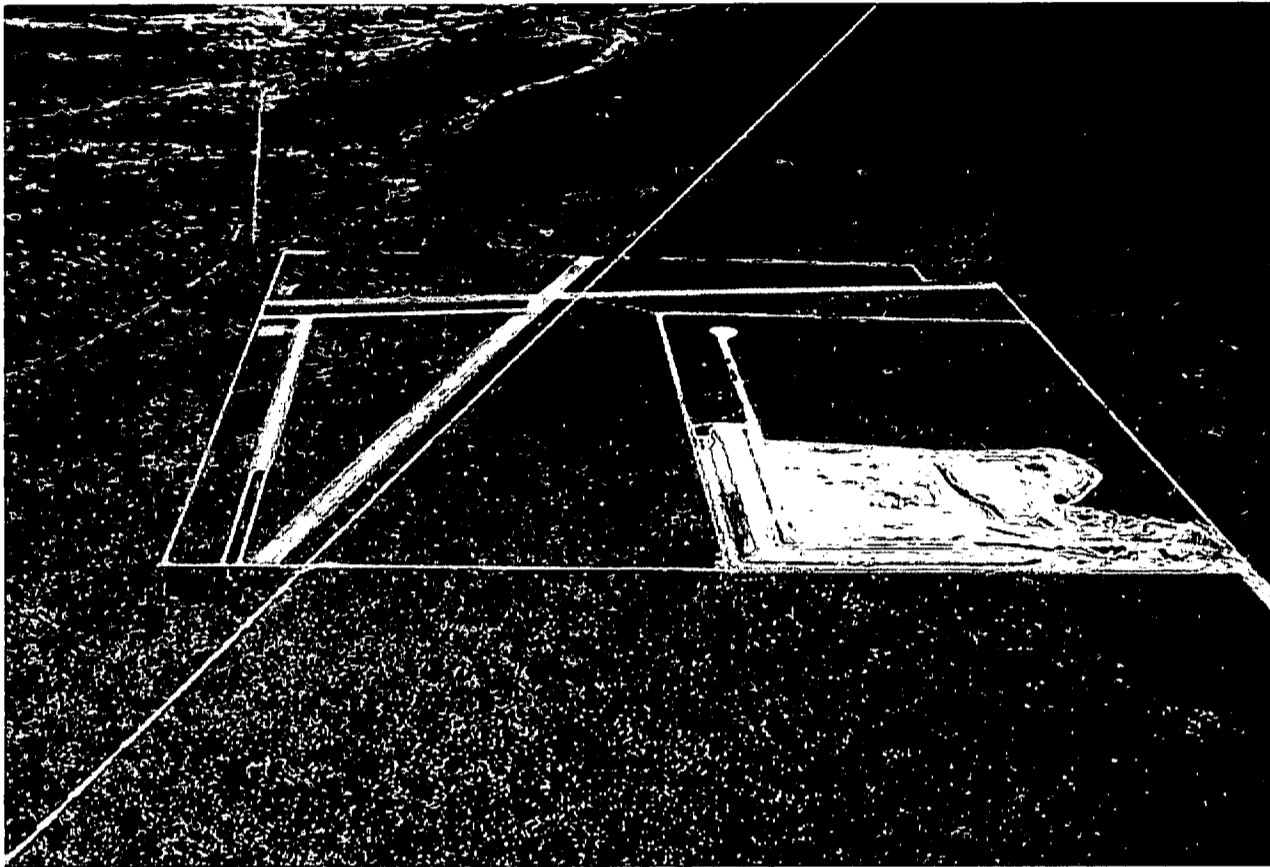
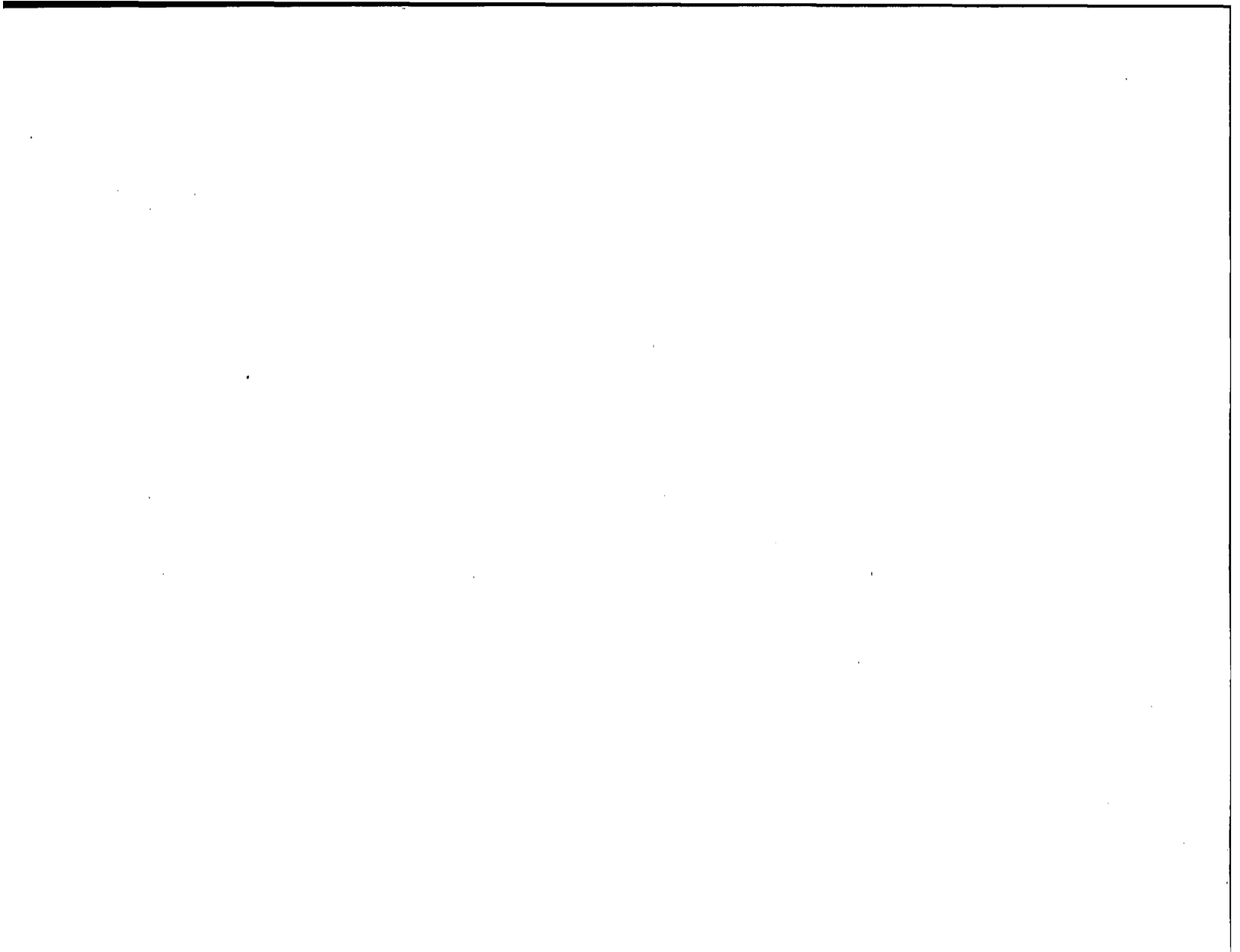

Figure 1. UVI UAS airfield looking north, located next to the Cochise County landfill.



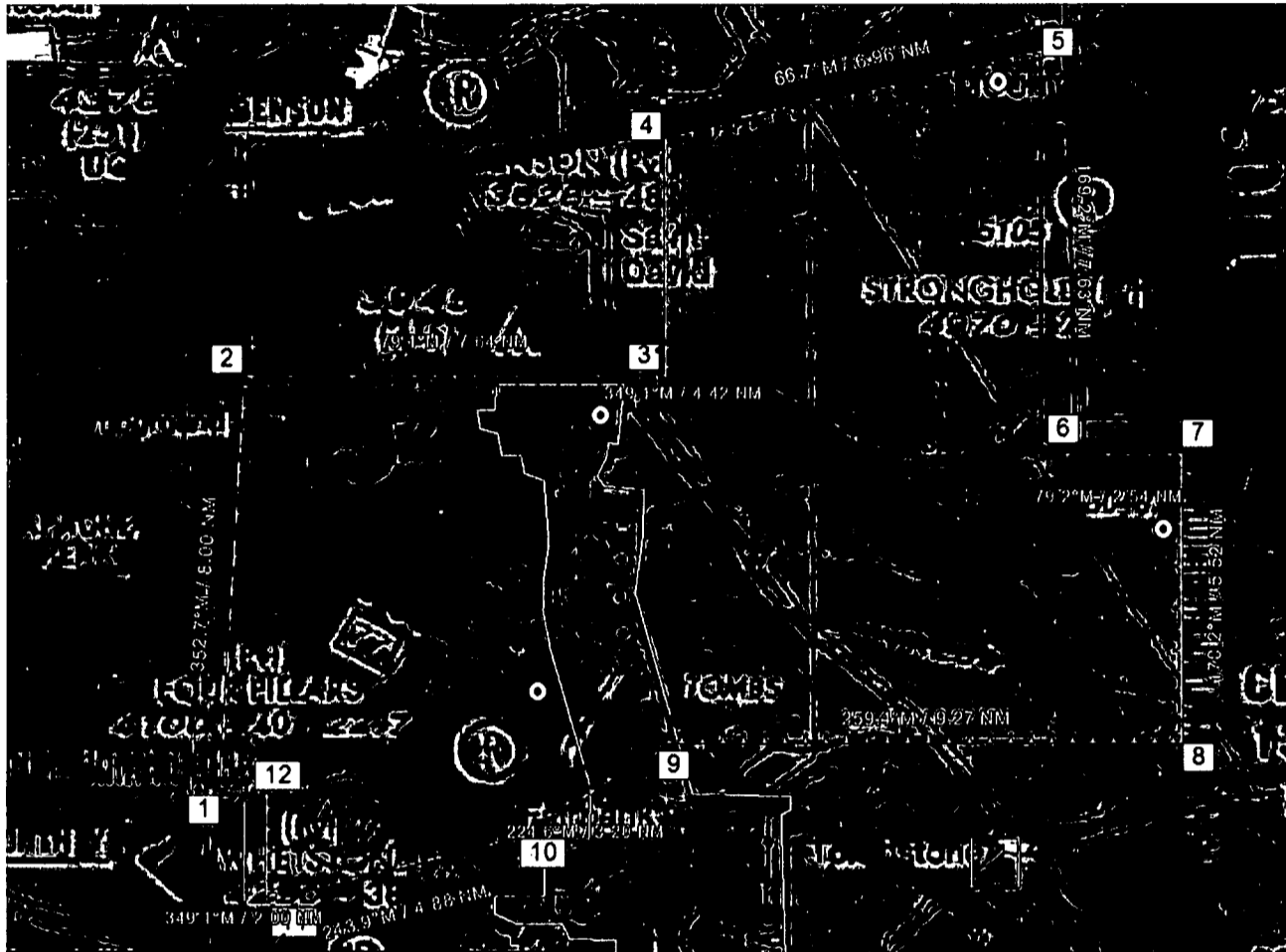
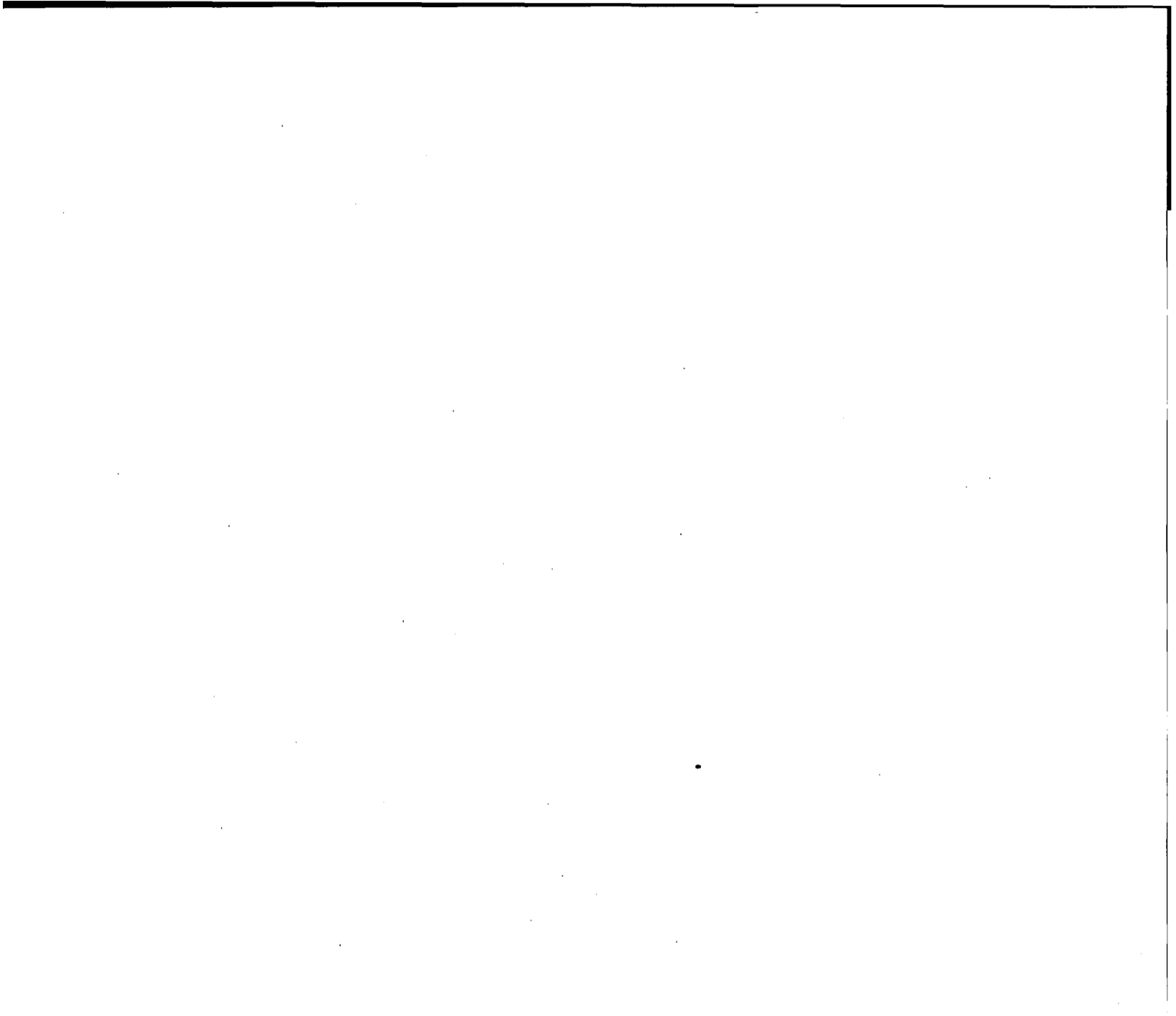

Figure 2. Phoenix Sectional, FHU 004/08.5, 4225' Elevation, N 31° 43' 30", W 110° 17' 47".

d. Alternate flight test area.

United States Air Force Academy  
2346 Academy Dr, Colorado Springs, CO 80840

The United States Air Force Academy (USAFA) has defined a Small UAS operating area in the northwest corner of the base in accordance with the FAA DoD MOU. The Cobra UAS flight area will utilize a subset of this area and operate within 1 NM from the landing strip. The pattern altitude is 600' AGL, and flight outside the landing pattern will be 2000' AGL and below. The center of the landing area is at N 39° 01' 02.54", W 104° 53' 30.79". The specific site is within Alert Area A260, but outside of KAFF Class D and Colorado Springs Class E airspace. The flight area is completely within the USAFA Base Boundary. The runway is a 1400' macadam strip oriented N/S between two athletic fields with an elevation of 7060'. Figure 2 shows the Containment Area, the landing pattern and runway. The USAFA will control ground access and limit USAF aircraft overflight during the demonstration. **Operations at the USAFA will require written request (email is acceptable) from the Raytheon UAS Chief Pilot to AIR-200. An acknowledgement authorizing subsequent operations must be received from AIR-200 and attached to these operating limitations.**



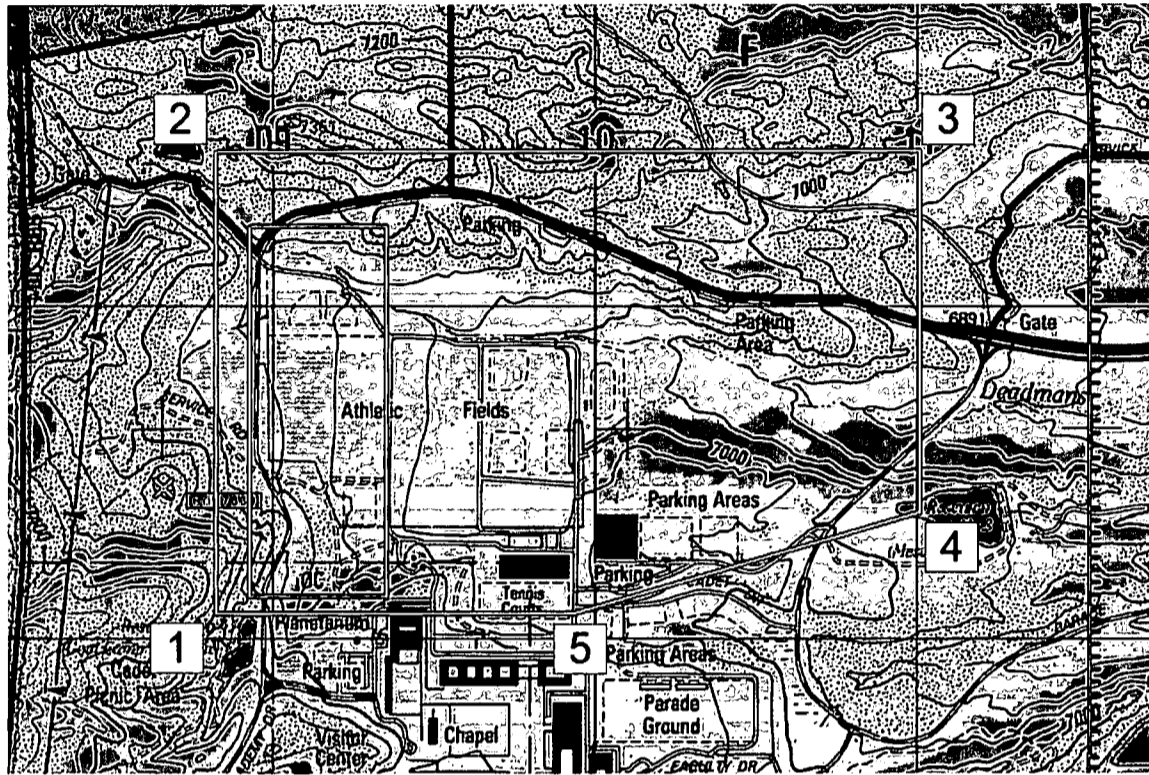
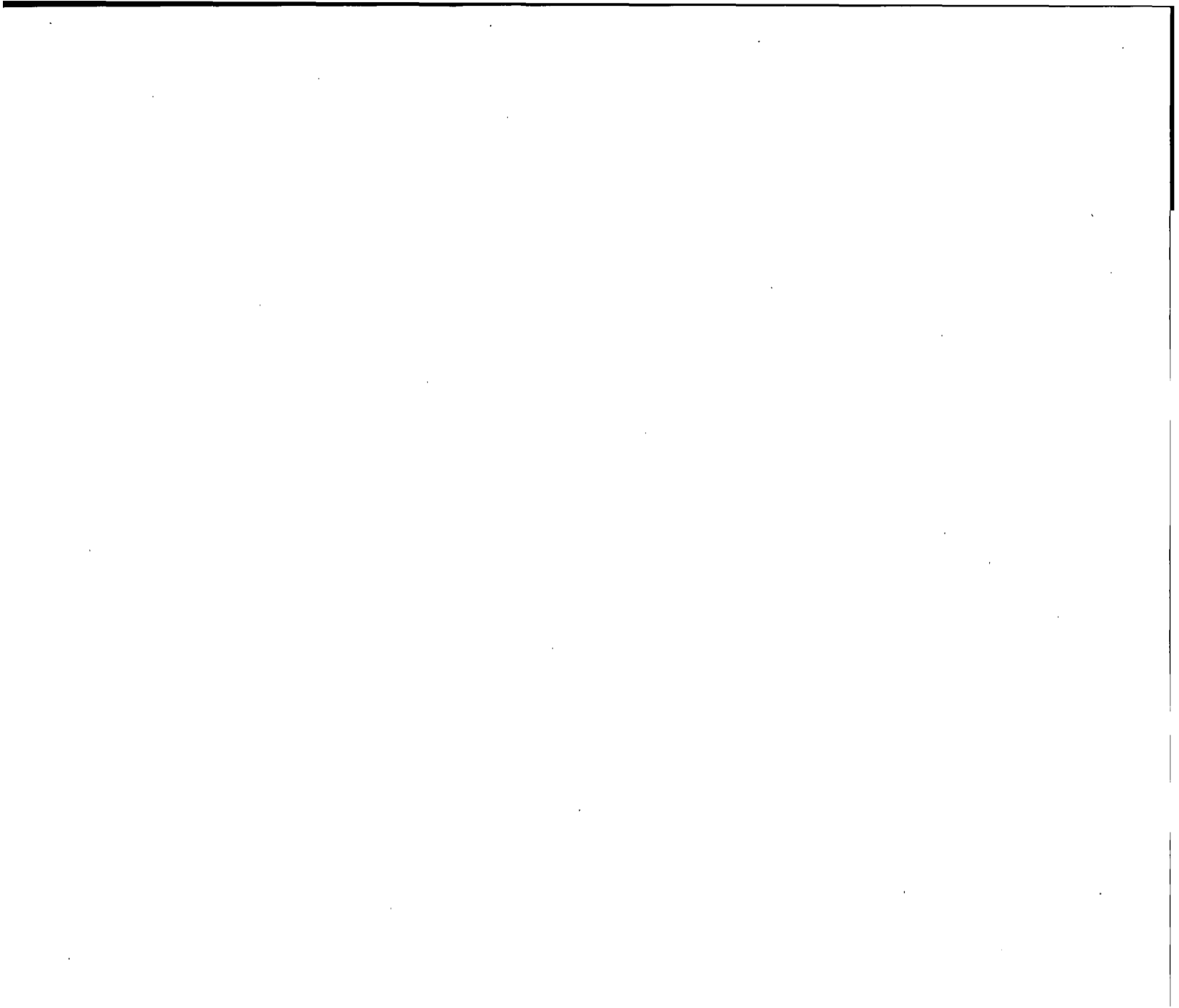

Figure 3: USAFA Cobra UAS Demonstration Area

The following grid coordinates define the AFA Cobra Demo containment area:

- |    |                  |                   |            |
|----|------------------|-------------------|------------|
| 1. | N 39° 00' 42.00" | W 104° 53' 53.00" |            |
| 2. | N 39° 01' 27.00" | W 104° 53' 53.00" | 0.7NM/0°   |
| 3. | N 39° 01' 27.00" | W 104° 52' 22.00" | 1.2NM/90°  |
| 4. | N 39° 00' 52.00" | W 104° 52' 22.00" | 0.6NM/180° |
| 5. | N 39° 00' 42.00" | W 104° 53' 07.00" | 0.6NM/254° |
| 1. | N 39° 00' 42.00" | W 104° 53' 53.00" | 0.6NM/270° |



In Figure 4 below, the containment area is the very small yellow box in the northwest corner of Alert Area 260. The dark blue line is the AFA Base Boundary. The light blue hashed line defines Alert Area 260. The red line shows the center of Victor Airway 108. The purple hashed line defines the Colorado Springs Class C/E airspace.

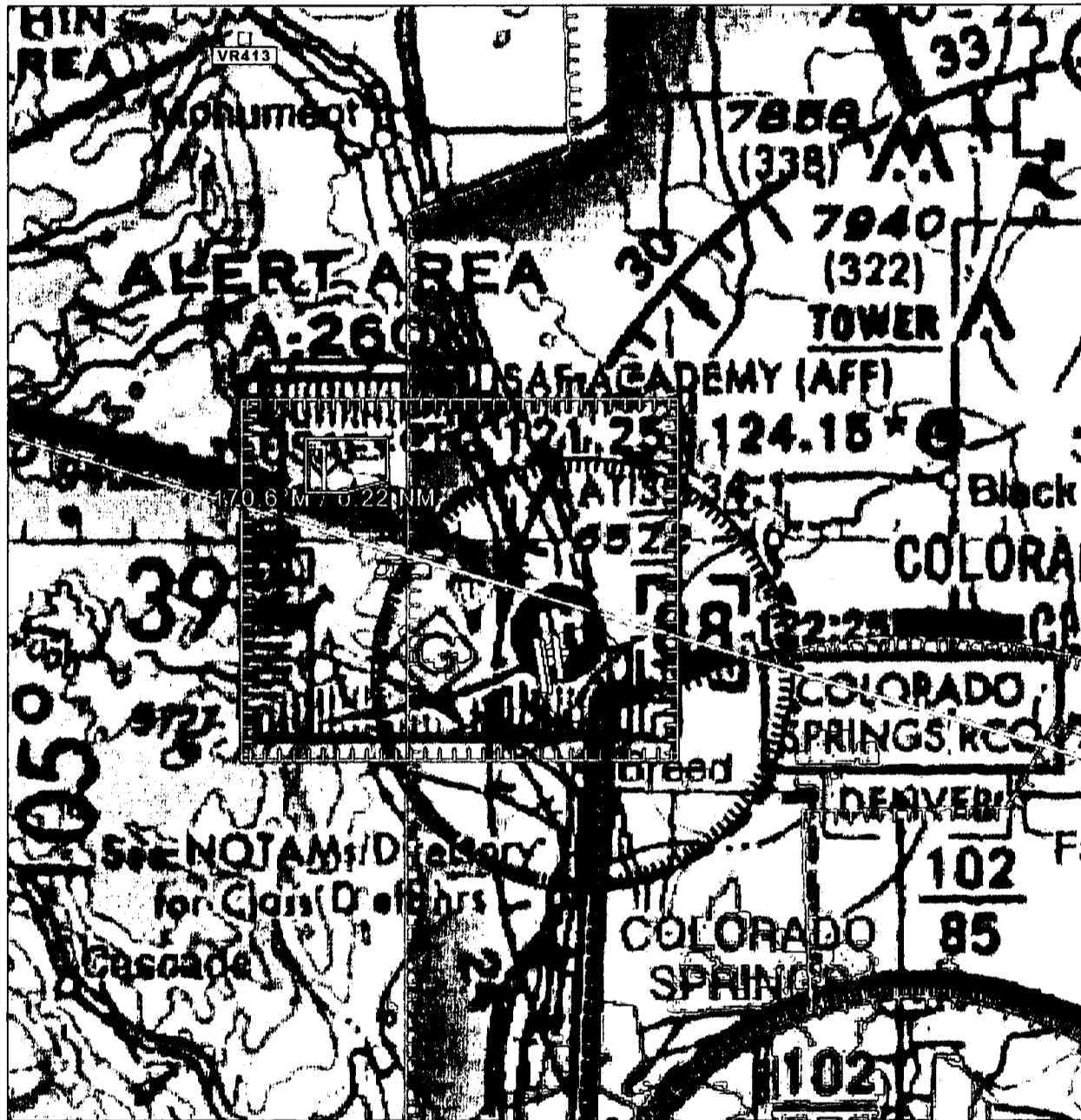
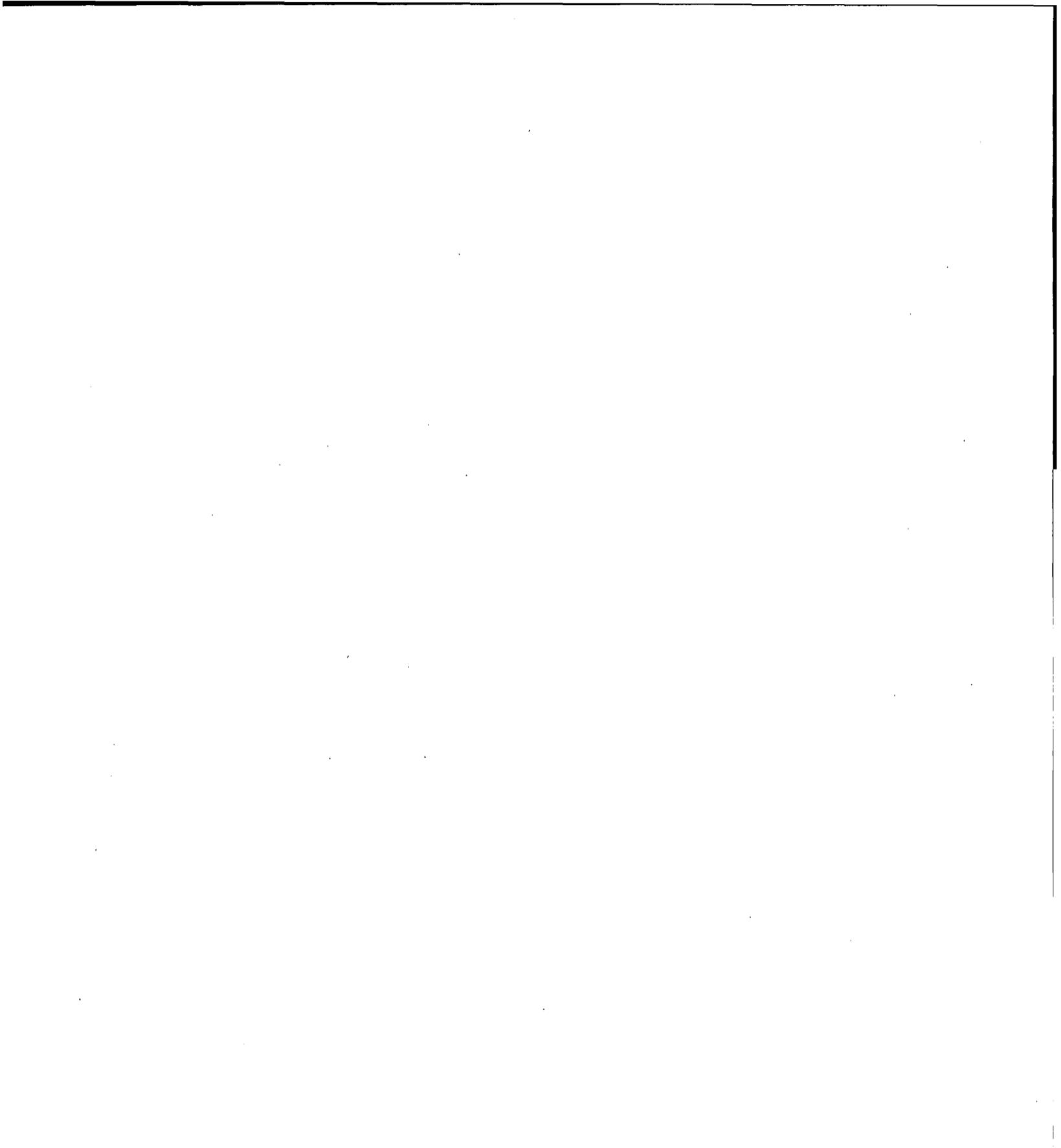

Figure 4: Containment Area

**e. Criteria for remaining in the flight test area.** The UAS PIC must ensure all UA flight operations remain within the lateral and vertical boundaries of the flight test area. Furthermore, the UAS PIC must take into account all factors that may affect the capability





October 24, 2008

of the UA to remain within the flight test area. This includes, but is not limited to, considerations for wind, gross weight, and glide distances.

**f. Incident/accident reporting.** Any incident/accident and any flight operation that transgresses the lateral or vertical boundaries of the flight test area or any restricted airspace must be reported to the FAA within 24 hours. This information must be reported to the Unmanned Aircraft Program Office, AIR-160. AIR-160 can be reached by telephone at 202-385-4636 and fax at 202-385-4651. Accidents must be reported to the National Transportation Safety Board (NTSB) per instructions contained on the NTSB Web site: [www.nts.gov](http://www.nts.gov). Further flight operations must not be conducted until the incident is reviewed by AIR-160 and authorization to resume operations is provided to Raytheon Missile Systems.

## **5. UA Pilots and Observers.**

### **a. UA PIC roles and responsibilities.**

- (1) The UA PIC must perform crew duties for only one UA at a time.
- (2) All flight operations must have a designated UA PIC. The UA PIC has responsibility over each flight conducted and is accountable for the UA flight operation.
- (3) The UA PIC is responsible for the safety of the UA as well as persons and property along the UA flight path. This includes, but is not limited to, collision avoidance and the safety of persons and property in the air and on the ground.
- (4) The UA PIC must avoid densely populated areas (§ 91.319) and exercise increased vigilance when operating within or in the vicinity of published airway boundaries.

### **b. UA PIC certification and ratings requirements.**

- (1) The UA PIC must hold and be in possession of, at a minimum, an FAA private pilot certificate, with either an airplane, rotorcraft, or powered-lift category; and single- or multiengine class ratings, appropriate to the type of UA being operated.
- (2) The UA PIC must have and be in possession of a valid second-class airman medical certificate issued under 14 CFR part 67, Medical Standards and Certification.

### **c. UA PIC currency, flight review, and training.**

- (1) No person may act as pilot in command of an unmanned aircraft unless that person has made at least three takeoffs and three landings in manned aircraft within the preceding 90 days acting as the sole manipulator of the flight controls.
- (2) The UA PIC must have a flight review in manned aircraft every 24 calendar months in accordance with § 61.56, Flight review.
- (3) The UA PIC must maintain currency in unmanned aircraft in accordance with Raytheon Missile Systems company procedures.
- (4) The UA PIC must have a flight review in unmanned aircraft every 24 calendar months in accordance with Raytheon Missile Systems company procedures.
- (5) All UA PICs must have successfully completed applicable Raytheon Missile Systems training for the UAS.

### **d. Supplemental UA pilot roles and responsibilities.**

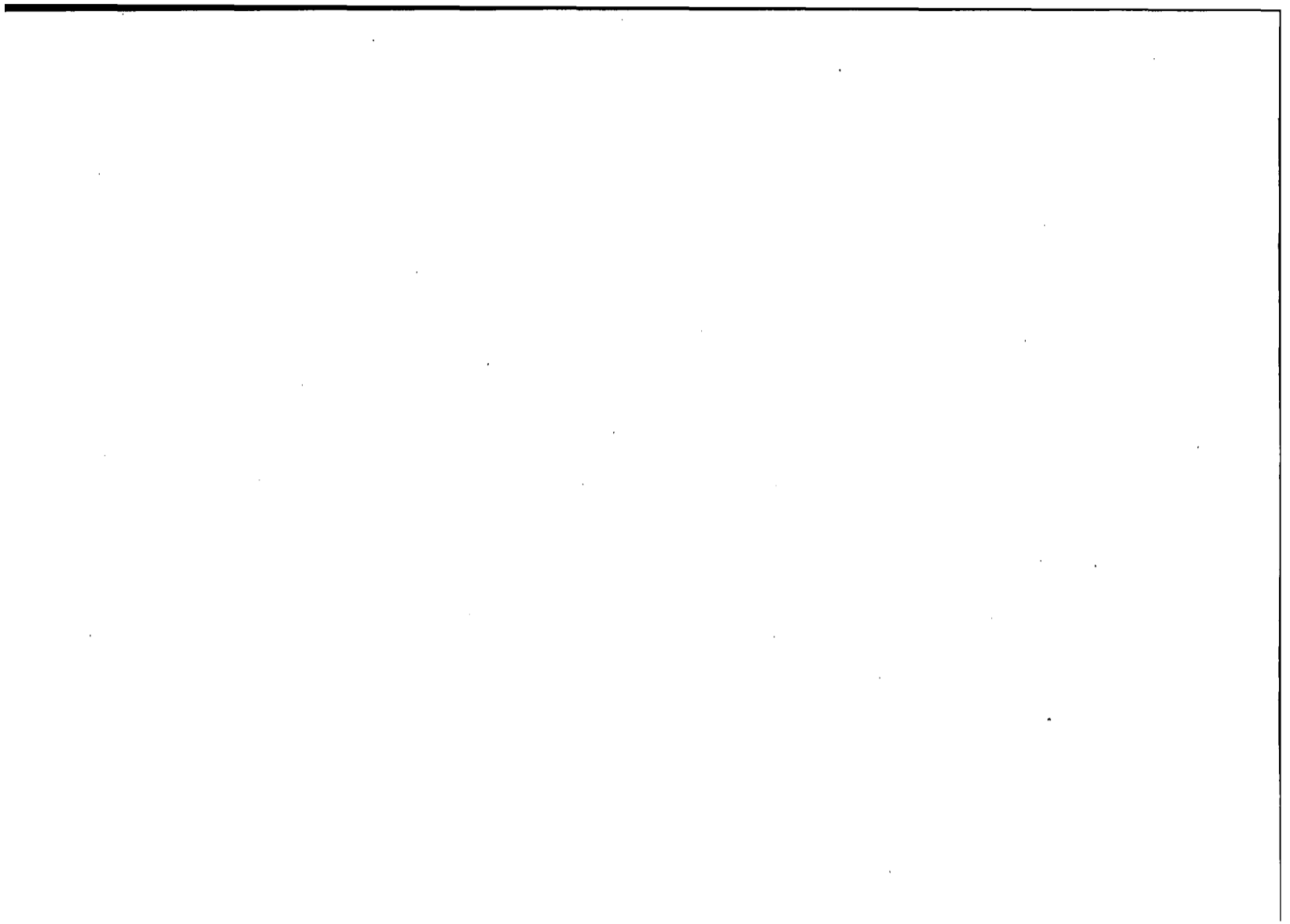

October 24, 2008

(1) Any additional UA pilot(s) assigned to a crew station during UA flight operations will be considered a supplemental UA pilot.

(2) A supplemental UA pilot assists the PIC in the operation of the UA and may do so at the same or a different control station as the PIC. The UA PIC will have operational override capability over any supplemental UA pilots, regardless of position.

(3) A supplemental UA pilot must perform crew duties for only one UA at a time.

**e. Supplemental UA pilot certification.**

(1) The supplemental UA PIC need not be a certificated pilot, but must have successfully completed a recognized private pilot ground school program.

(2) All supplemental pilots must have and be in possession of a valid second-class airman medical certificate issued under 14 CFR part 67, Medical Standards and Certification.

**f. Supplemental UA pilot currency, flight review, and training.**

(1) All UA pilots must maintain currency in unmanned aircraft in accordance with Raytheon Missile Systems company procedures.

(2) All UA pilots must have a flight review in unmanned aircraft every 24 calendar months in accordance with Raytheon Missile Systems company procedures.

(3) All UA pilots must have successfully completed applicable Raytheon Missile Systems training for the UAS.

**g. Observer roles and responsibilities.** The task of the observer is to provide the UA PIC(s) with instructions to maneuver the UA clear of any potential collision with other traffic. To satisfy these requirements:

(1) The observer must perform crew duties for only one UA at a time.

(2) At no time will the observer permit the UA to operate beyond the line-of-sight necessary to ensure maneuvering information can be reliably determined.

(3) At no time will the observer conduct his/her duties more than one (1) nautical mile laterally or 2000 feet vertically from the UA.

(4) An observer must maintain continuous visual contact with the UA to discern UA attitude and trajectory in relation to conflicting traffic.

(5) Observers must continually scan the airspace for other aircraft that pose a potential conflict.

(7) All flight operations conducted in the flight test area must have an observer to perform traffic avoidance and visual observation to fulfill the see-and-avoid requirement of § 91.113, Right-of-way rules: Except water operations.

**h. Observer certification.**

(1) All observers must either hold, at a minimum, an FAA private pilot license or must have successfully completed specific observer training acceptable to the FAA. An observer does not require currency as a pilot.

(2) All observers must have in their possession a valid second-class airman medical certificate issued under part 67.

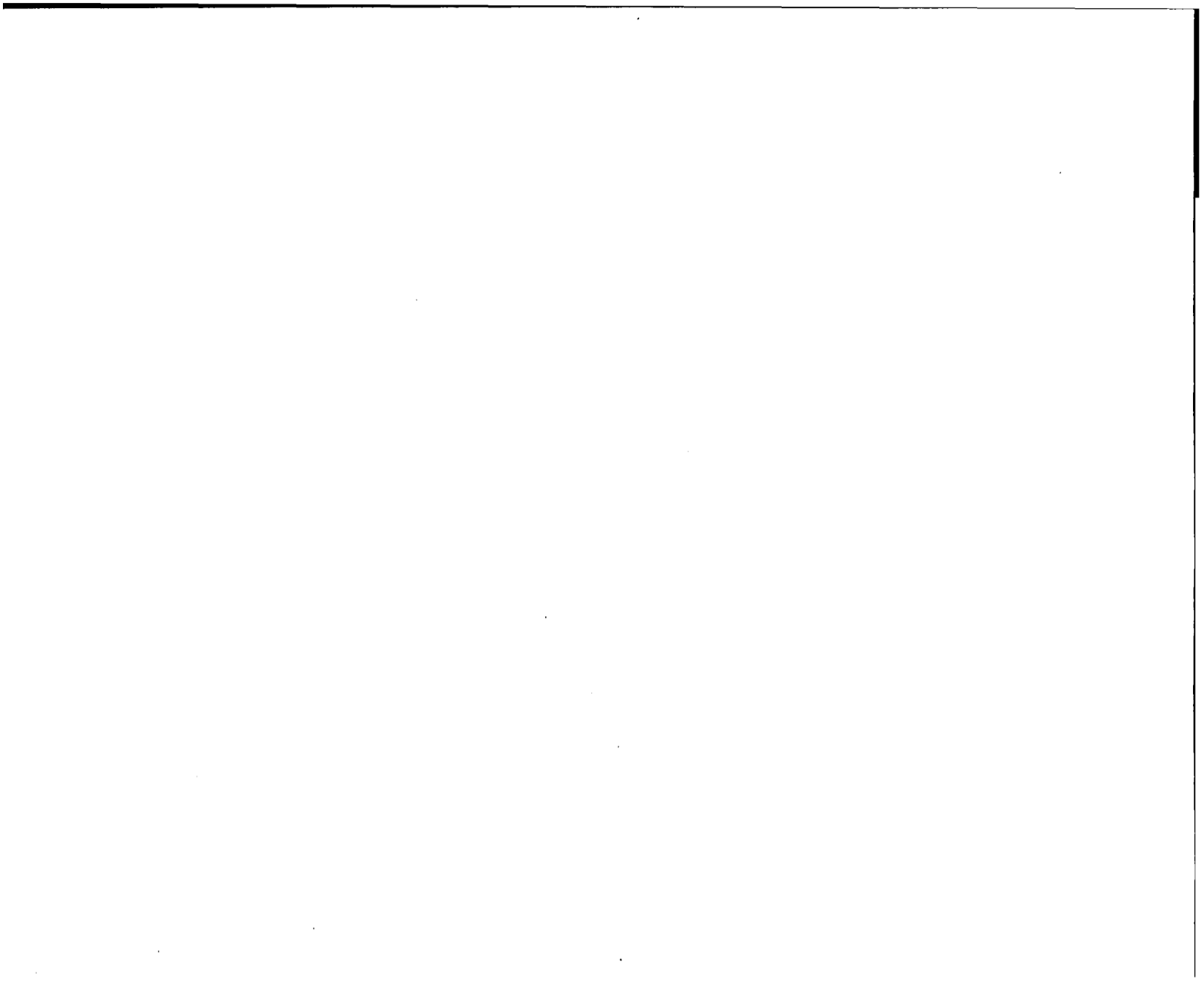

**i. Observer training.**

(1) All observers must be thoroughly trained, be familiar with, and possess operational experience with the equipment being used. Such training is necessary for observation and detection of other aircraft for collision avoidance purposes as outlined in Raytheon Missile Systems program letter.

(2) All observers must have successfully completed applicable Raytheon Missile Systems training for the UAS.

**6. Equipage.**

**a.** The UAS must be equipped with an operable transponder with Mode C or Mode S, and two-way communications equipment allowing communications between the UA pilot, observers, all UAS control stations, and ATC.

**b.** The UA and chase aircraft must be equipped with operable navigation, position, and/or strobe/anti-collision lights. Strobe/anti-collision lights must be illuminated during all operations.

**7. Communications.**

**a. Before UA flights.**

(1) Before conducting operations, the frequency spectrum used for operation and control of the UA must be approved by the Federal Communications Commission or other appropriate government oversight agency.

(2) Raytheon shall contact Air Traffic Control prior to flight operations. Raytheon shall select and transmit transponder code 1200 unless otherwise directed by local Air Traffic Control. Upon initial contact with ATC, the UA PIC must indicate the experimental nature in accordance with § 91.319.

**b. During UA flights.**

(1) Appropriate air traffic frequencies must be monitored during flight operations.

(2) All UA positions must maintain two-way communications with each other during all operations. If unable to maintain two-way communication, the UA PIC will expeditiously return the UA to its base of operations while remaining within the flight test area and conclude the flight operation.

**8. Flight Conditions.**

**a. Daylight operations.** All flight operations must be conducted during daylight hours in visual meteorological conditions (VMC), including cloud clearance minimums as specified in § 91.155, Basic VFR weather minimums. Flight operation in instrument meteorological conditions (IMC) is not permitted.

**b. Prohibitions.**

(1) The UA is prohibited from aerobatic flight, that is, an intentional maneuver involving an abrupt change in the UA's attitude, an abnormal acceleration, or other flight action not necessary for normal flight. (See § 91.303, Aerobatic flight.)

(2) Flight operations must not involve carrying hazardous material or the dropping of any objects or external stores.



October 24, 2008

(3) No individual control station may be used to operate more than one UA at one time.

**c. Transponder requirements.** The UA must operate an approved operational Mode C or Mode S altitude encoding transponder during all flight operations.

**d. Transponder failure.** In the event of transponder failure, the UA must conclude all flight operations and expeditiously return to its base of operations within the prescribed limitations of this authorization.

**e. Notice to airman.** Raytheon Missile Systems must request the issuance of a Notice to Airman (NOTAM) through the appropriate FAA Automated Flight Service Station at least 24 hours before flight operation.

#### **9. Flight Termination and Lost Link Procedures.**

**a. Flight termination.** In accordance with Raytheon Missile Systems program letter, dated 09/30/08, flight operations must be discontinued at any point that safe operation of the UA cannot be maintained or if hazard to persons or property is imminent.

**b. Lost link procedures.** In the event of lost link, the UA must provide a means of automatic recovery that ensures airborne operations are predictable and that the UA remains within the flight test area. The observer, all other UAS control stations, and the appropriate ATC facility will be immediately notified of the lost link condition and the expected UA response.

#### **10. Maintenance and Inspection.**

**a. General requirements.** The UAS must not be operated unless it is inspected and maintained in accordance with the FAA-accepted Cobra UAS Inspection Program, dated 04/21/2008, or later accepted FAA revision. Raytheon Missile Systems must establish and maintain aircraft maintenance records (see paragraph 10(d) below).

**b. Inspections.** No person may operate this UAS unless within the preceding 12 calendar months unless it has had a condition inspection performed according to the Cobra UAS Inspection Program, dated 04/21/2008. The UAS must also have been found to be in a condition for safe operation. This inspection will be recorded in the UAS maintenance records as described in paragraph 10(d) below.

**c. Authorized inspectors.** Only those individuals trained and authorized by Raytheon Missile Systems and acceptable to the FAA may perform the inspections and maintenance required by these operating limitations.

**d. Maintenance and inspection records.** Maintenance and inspections of the UAS must be recorded in the UAS maintenance records. The following information must be recorded:

(1) Maintenance record entries must include a description of the work performed, the date of completion for the work, the UAS's total time-in-service, and the name and signature of the person performing the work.

(2) Inspection entries must contain the following, or a similarly worded, statement:  
*I certify that this UAS was inspected on (date), in accordance with the scope and detail of the Raytheon Missile Systems Cobra UAS Inspection Program, and was found to be in a condition for safe operation.*

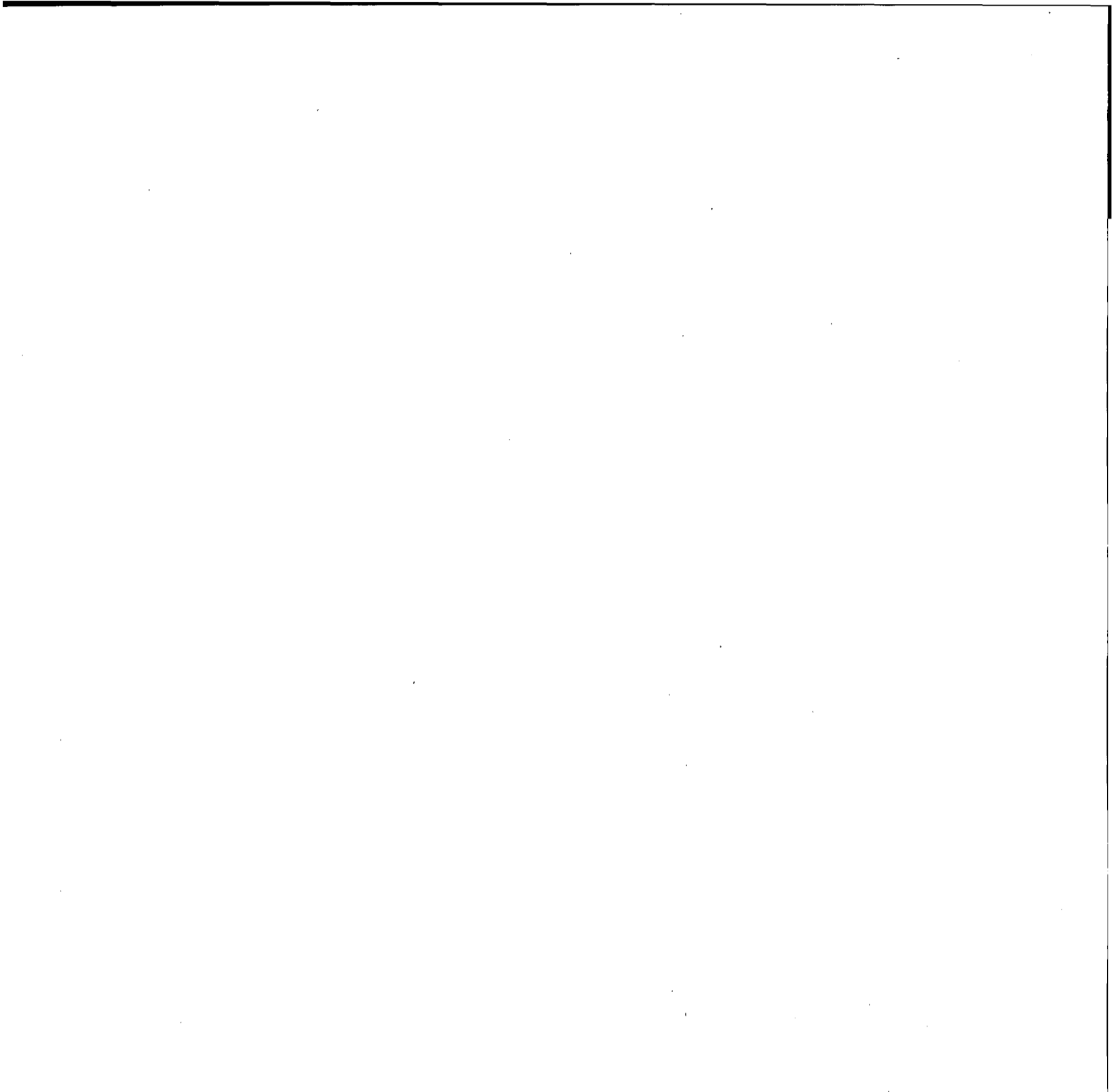



October 24, 2008

(3) UAS instruments and equipment required to be installed must be inspected and maintained in accordance with the requirements of the Raytheon Missile Systems Cobra UAS Inspection Program. Any maintenance or inspection of this equipment must be recorded in the UAS maintenance records.

(4) No person may operate this UAS unless the altimeter system and transponder have been tested within the preceding 24 calendar months in accordance with § 91.413, ATC transponder tests and inspections. These inspections will be recorded in the UAS maintenance records.

**11. Information Reporting.** Raytheon Missile Systems will provide the following information on a monthly basis, via email, to Mr. Donald Grampp of the FAA UAPO. Mr. Grampp's email address is donald.e.grampp@faa.gov.

- a. Number of flights conducted under this certificate.
- b. Pilot duty time per flight.
- c. Unusual equipment malfunctions (hardware or software).
- d. Deviations from ATC instructions.
- e. Unintended entry into lost link flight mode that results in a course change.

**12. Revisions and Other Provisions.**

**a. Experimental certificates, program letters, and operating limitations.** The experimental certificate, FAA-accepted Raytheon Missile Systems program letter, and operating limitations cannot be reissued, renewed, or revised without application being made to the Phoenix Manufacturing Inspection District (MIDO), in coordination with AIR-200. AIR-200 will be responsible for FAA Headquarters internal coordination with the Aircraft Certification Service, Flight Standards Service, Air Traffic Organization, Office of the Chief Council, and Office of Rulemaking.

**b. Certificates of waiver or authorization.** The Production and Airworthiness Division, AIR-200 and the Phoenix MIDO shall be notified immediately if there is any plan for requesting a Certificate of Authorization or Waiver (COA) for UAS operations during the time period the Experimental Certificate is in effect. If the aircraft is authorized to operate under a COA, Raytheon must determine that the aircraft is in a condition for safe operation and appropriately configured for the purpose intended. A record entry will be made by an appropriately rated person to document that finding in the aircraft logbook.

**c. Amendments and cancellations.** The provisions and limitations annotated in this operational approval may be amended or cancelled at any time as deemed necessary by the FAA.

**d. Reviews of revisions.** All revisions to Raytheon Missile Systems FAA-accepted Inspection Program must be reviewed and accepted by the Scottsdale Flight Standards District Office.

**13. UAS Modifications.**

**a. Software and system changes.** All software and system changes will be documented as part of the normal maintenance procedures and will be available for inspection. All software and system changes must be inspected and approved per FAA-accepted Cobra UAS Inspection Program, dated 04/21/2008. All software changes to the aircraft and control station are categorized as major changes, and must be provided to AIR-200 in summary form at the time they are incorporated.

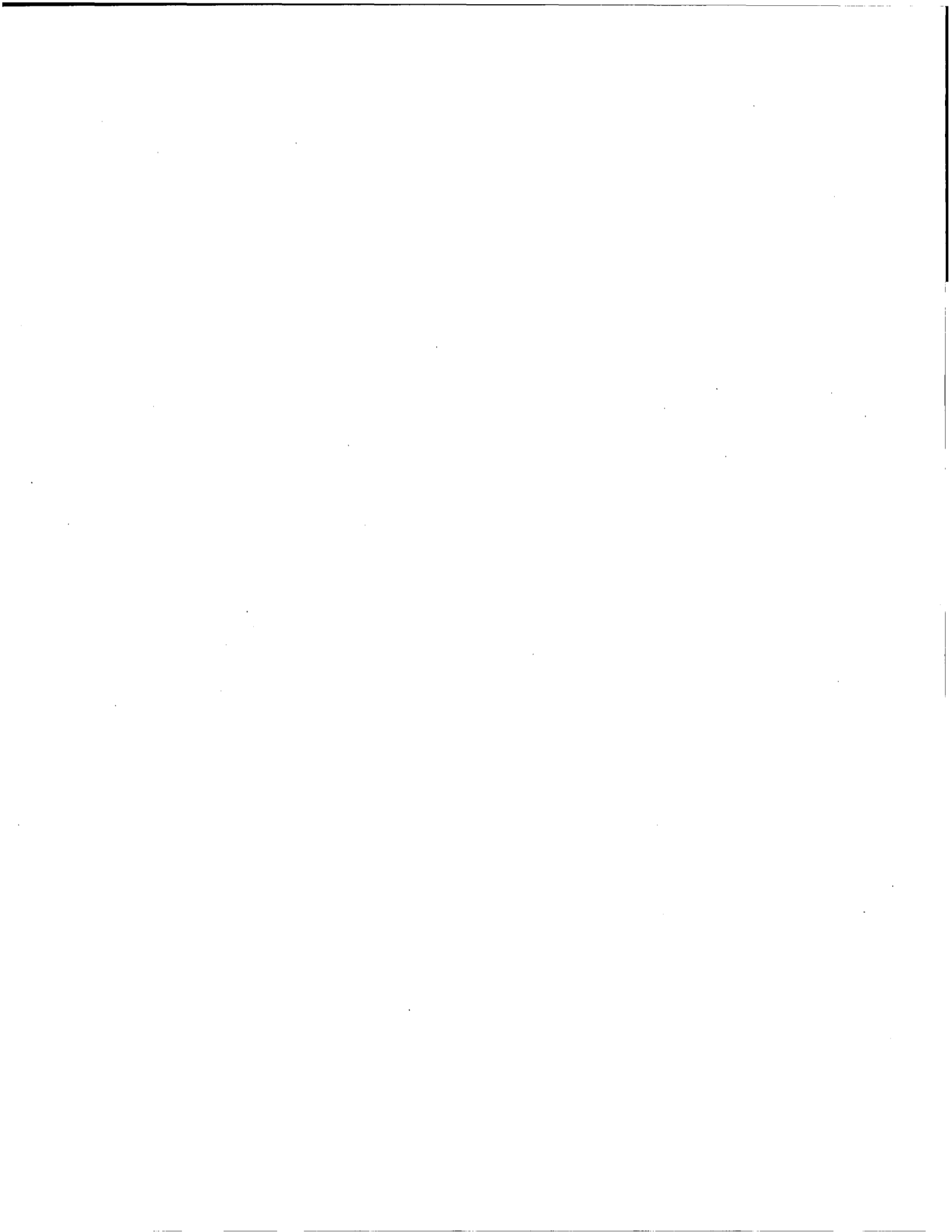

October 24, 2008

**b. Major modifications.** All major modifications, whether performed under the experimental certificate, COA, or other authorizations, that could potentially affect the safe operation of the system, must be documented and provided to the AIR-200 before operating the aircraft under this certificate. Major modifications incorporated under COA or other authorizations need to be provided only if the aircraft is flown under these authorizations during the effective period of the experimental certificate.

End of Limitations

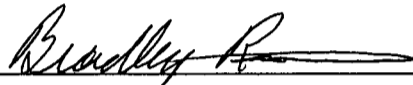

Bradley Roon  
Aviation Safety Inspector  
Phoenix Manufacturing Inspection District Office  
13951 N. Scottsdale Road  
Scottsdale, AZ 85254

Date: October 24, 2008

**The Special Airworthiness Certificate and accompanying Operating Limitations expire on October 24, 2009.**

**I certify that I have read and understand the operating limitations, and conditions, that are a part of the Special Airworthiness Certificate; FAA Form 8130-7 issued on October 24, 2008, for the purpose of Research and Development, Market Survey, and/or Crew Training.**

**This Special Airworthiness Certificate is issued for the Raytheon Missile Systems, UA model "Cobra," serial number 006, registration number N606RN.**

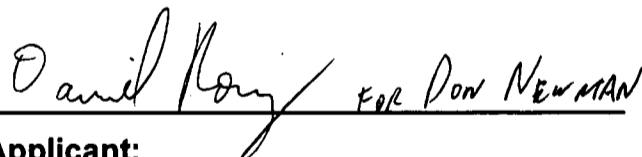

**Applicant:**

**Date: October 24, 2008**

**Name: Donald L. Newman**  
**Title: Director Unmanned Systems**  
**Company: Raytheon Missile Systems**

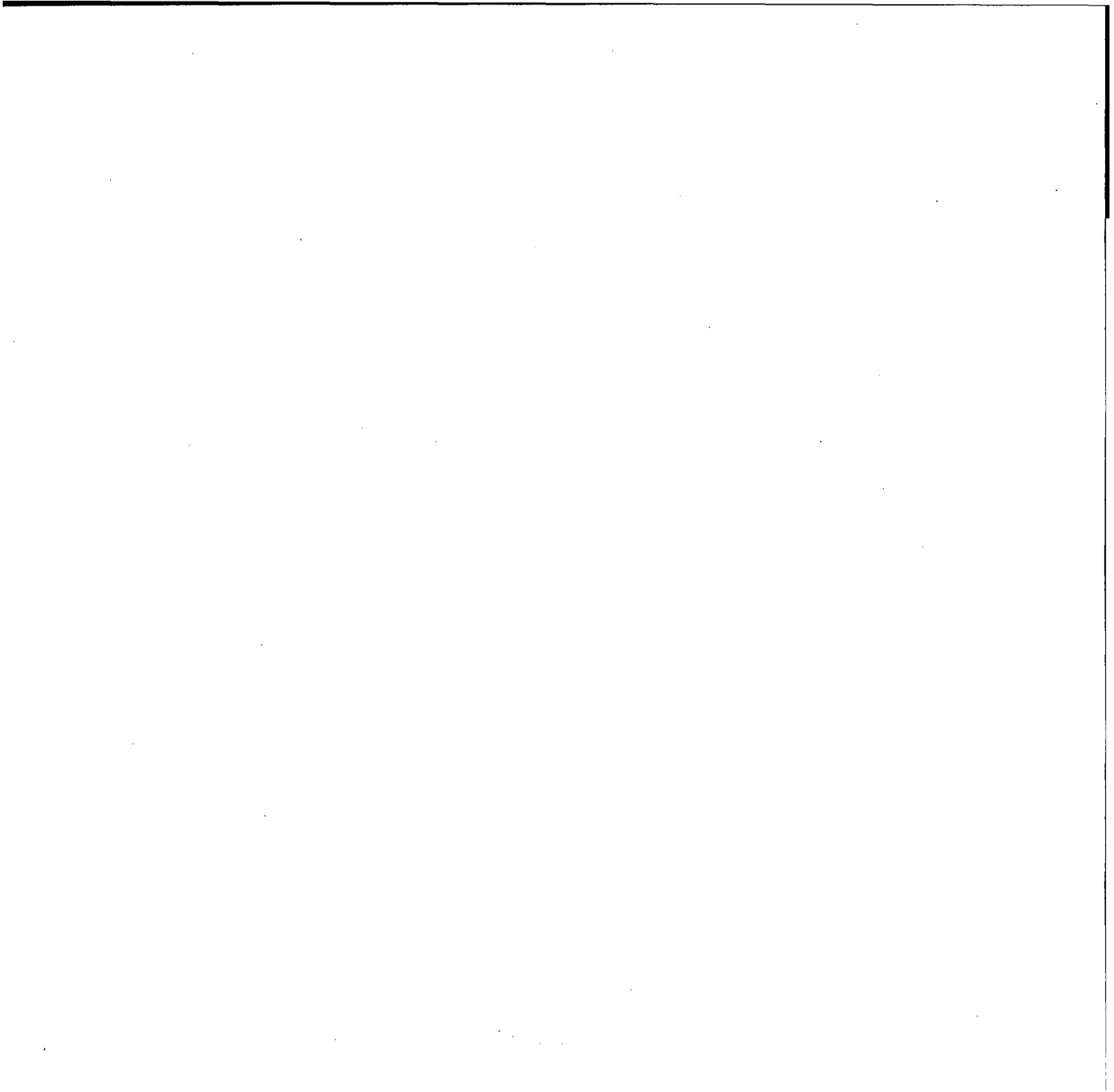

**Raytheon**

**Raytheon**

Program Letter (N606RN) for Unmanned Aircraft  
Systems, Experimental Airworthiness Certificate

Cobra UAS

Document ID: UNM-01-RR99818

Rev 3

09-30-08

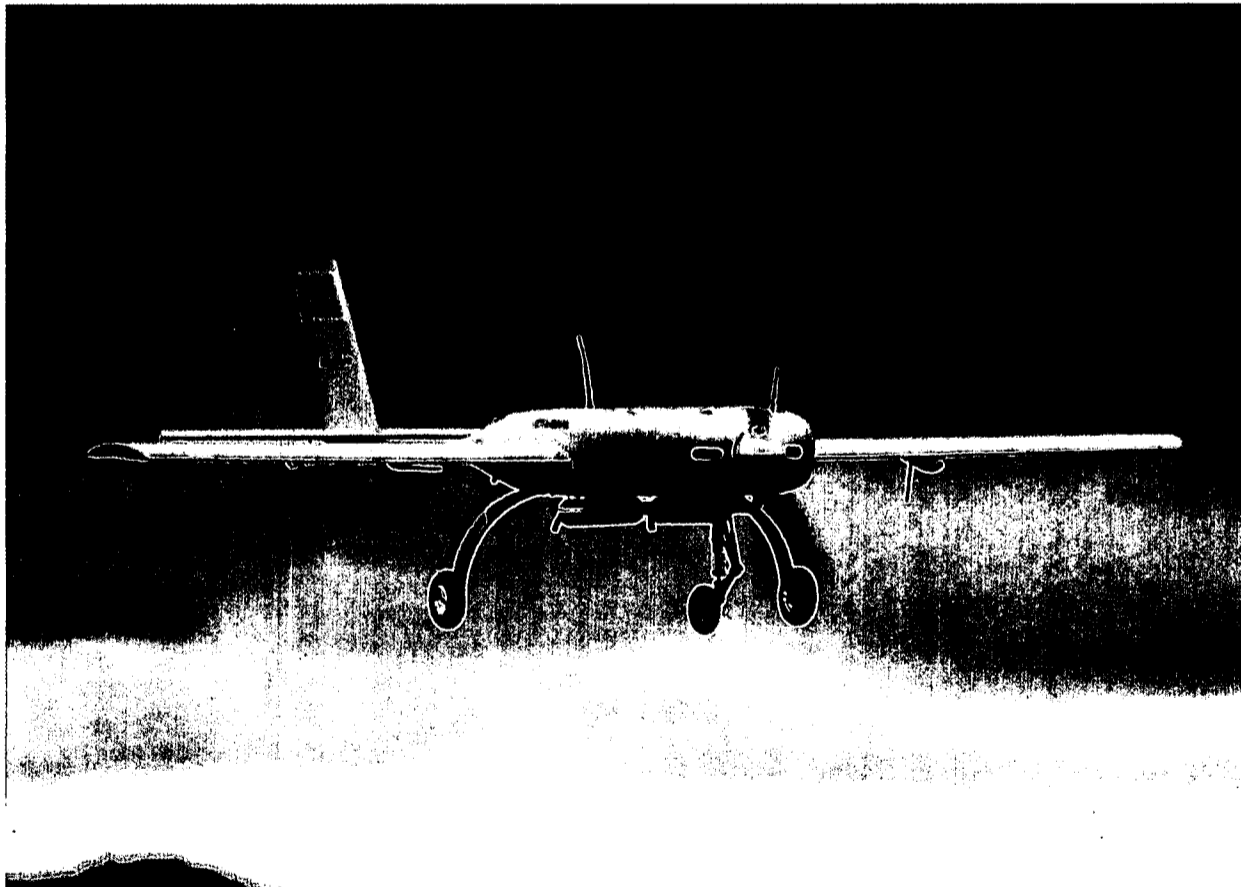

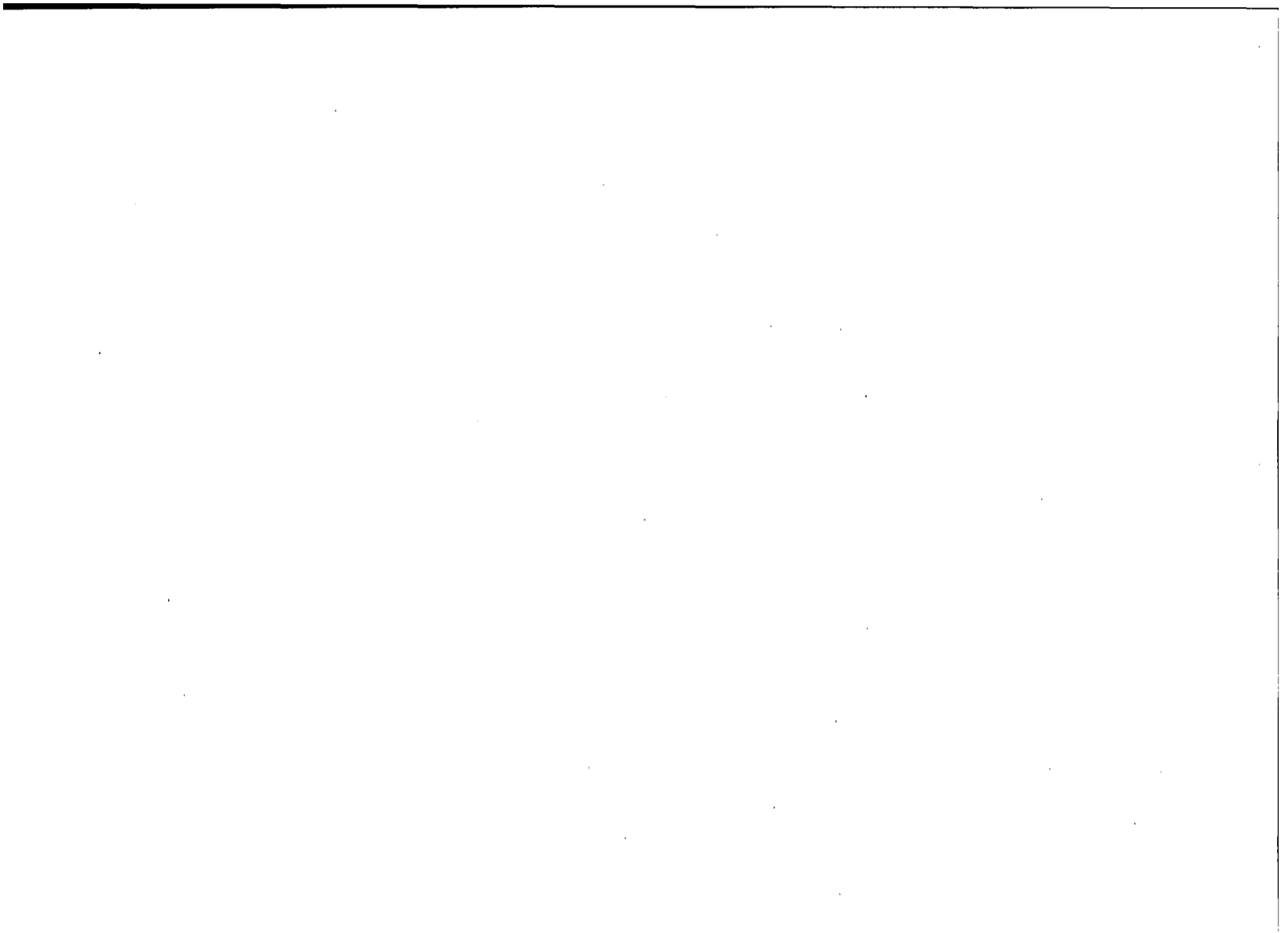

**Revision History**

<b>Revision No.</b>	<b>Description of Change</b>	<b>Date</b>	<b>Revised By</b>
Rev -	Original Document	02/21/07	
Rev 1	2 <sup>nd</sup> Year, Update Altitude, Pilot Data	09/27/07	MDB
Rev 2	USAFA Addition, Max Gross Wt, Prop	06/30/08	MDB
Rev 3	Annual Update, Fig. 8 Flight Termination options updated to current software	09/30/08	DNR

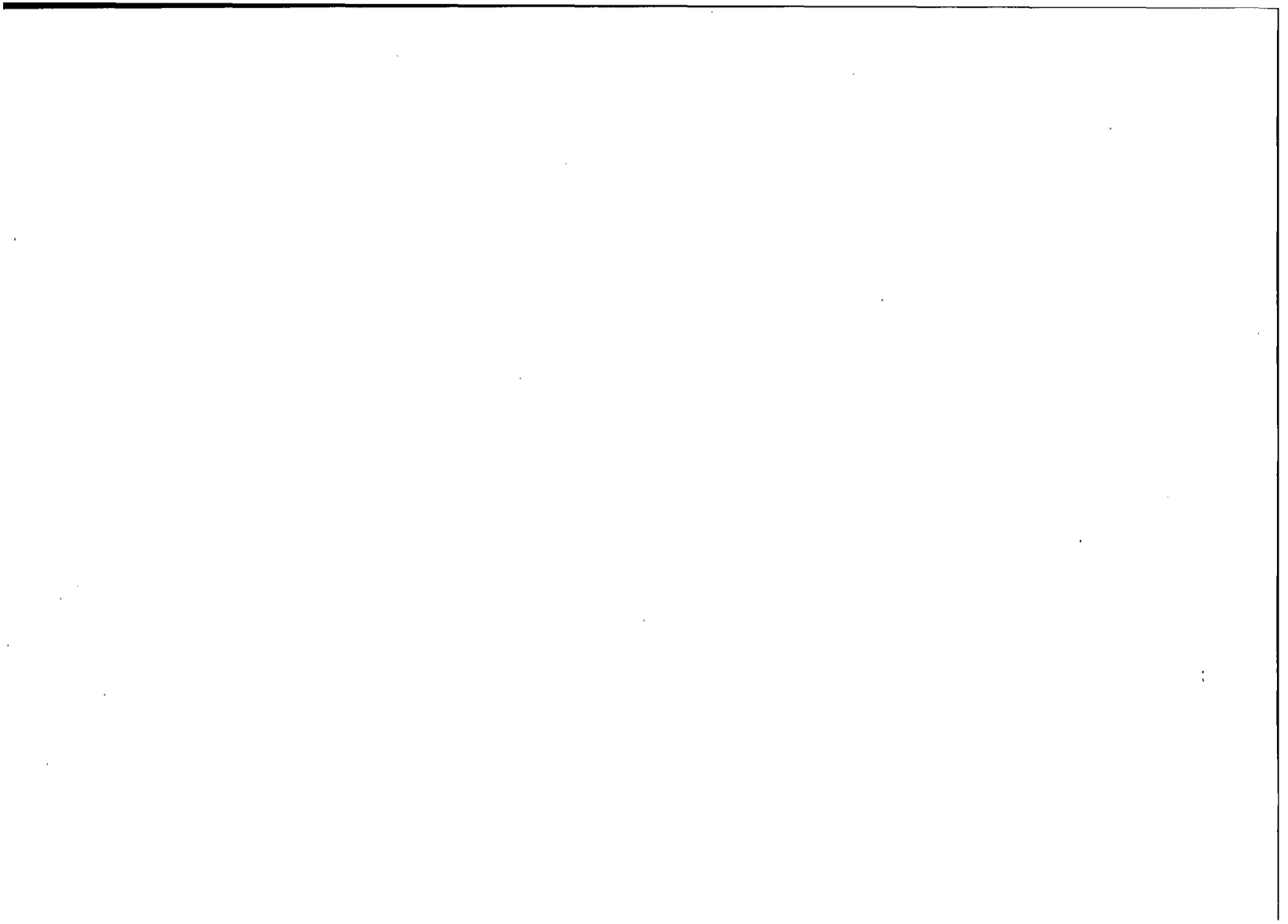



## Table of Contents

<b>Aircraft Specifications</b>	<b>1</b>
1. Define the experimental purpose(s) under which the aircraft is to be operated (14 CFR § 21.191)	2
2. Describe the purpose/scope of the experimental program for each 14 CFR § 21.191 experimental purpose sought (14 CFR § 21.193(b)(d))	2
3. Define the area(s) in which the experimental flights will be conducted	3
4. Aircraft Configuration	12
5. Inspection And Maintenance (14 CFR 91.7)	16
6. Pilot Qualification (14 CFR §§ 61.3, 61.5)	17
7. Aircraft Marking (14 CFR § 45)	19
8. ATC Transponder and Altitude Reporting System Equipment and Use (14 CFR § 91.215)	19
9. Method for See and Avoid (14 CFR § 91.113a)	20
10. Safety Risk Management	20
11. System Configuration	21
12. System Safety – Flight Termination and Lost Link	21
13. Command and Control	23
14. Control Stations	24
15. Control Frequencies	25
Appendix A - Cobra Drawings and Photographs	27
Appendix B - Cloud Cap Piccolo II Users Guide	30
Appendix C - Raytheon UAS Flight Manual	31
Appendix D - Cobra Weight and Balance	31
Appendix E - Minimum Equipment List	32
Appendix F - System Configuration Diagram	36
Appendix G - FAA UAS Safety Checklist	39
Appendix H – Acronym List	40

## Table of Figures

Figure: 1 Cobra UAS .....	2
Figure: 2 UVI Airfield.....	4
Figure: 3 UVI Containment Area .....	6
Figure: 4 USAFA Cobra UAS Demo .....	Error! Bookmark not defined.
Figure: 5 USAFA Containment Area .....	10
Figure: 6 Cobra 3 View Drawing.....	12
Figure: 7 MVCS CUCS.....	15
Figure: 8 Piccolo Autopilot Limits.....	22

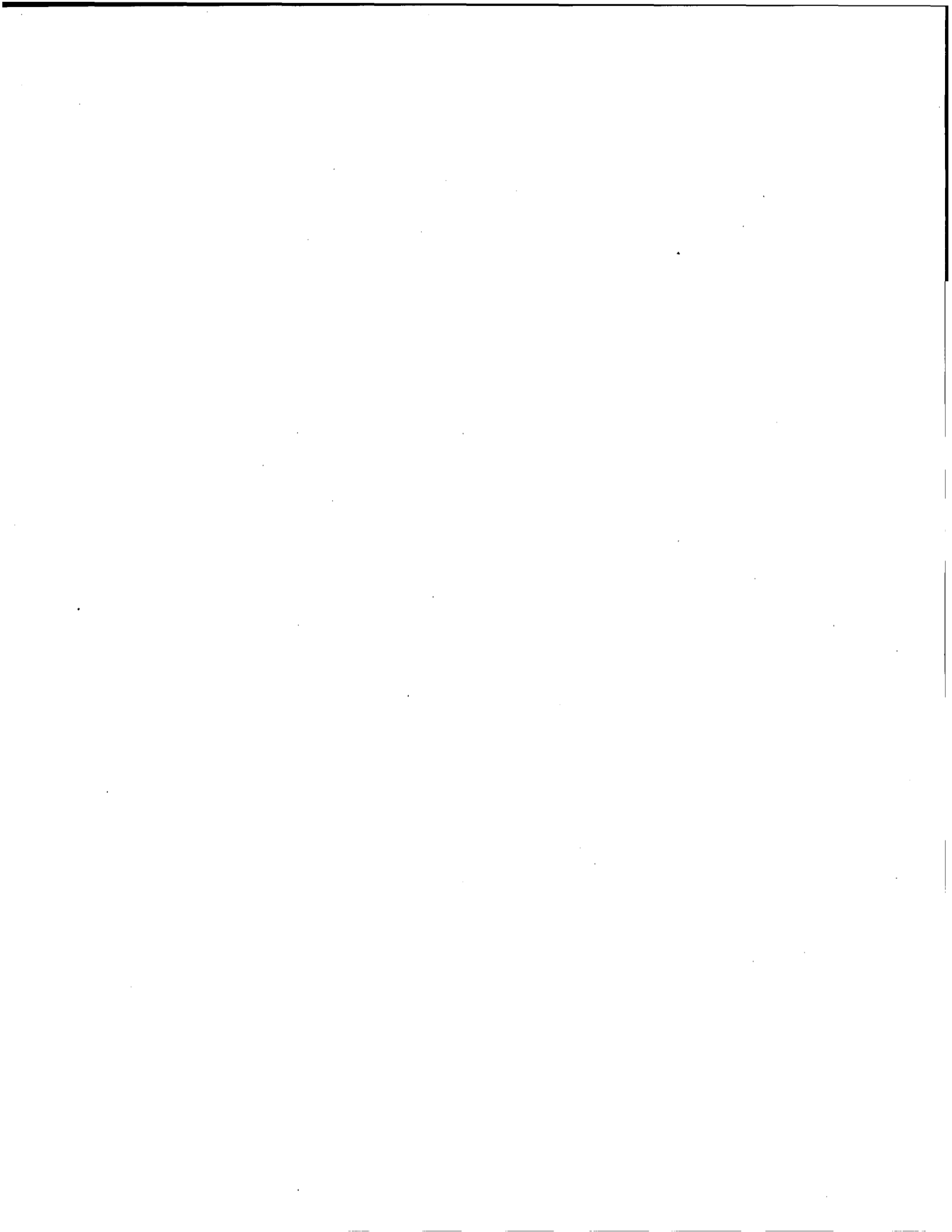

# Raytheon

## Aircraft Specifications

**Registered Owner Name:**  
Raytheon Company

**Registered Owner Address:**  
Raytheon Missile Systems  
Bldg M09, M/S 5  
P.O. Box 11337  
Tucson, AZ 85734-1337

### Aircraft Description:

The aircraft is an unmanned, composite, mid-wing monoplane with standard tail surfaces and a tractor engine. The vertical and horizontal stabilizers are attached to a composite tail boom. The control surfaces consist of full span flaperons, elevator and rudder. The landing gear is tricycle type with a steerable nosewheel, and the main landing gear is equipped with pneumatic brakes. The engine is a 16 hp, air-cooled, 2-cycle, 2 cylinder, opposed, and carbureted powerplant with an electronic ignition system, using gasoline with a 100:1 2-cycle oil mix. Primary electrical power comes from a 500 watt generator with a 180 watt regulator. A Lithium Polymer rechargeable battery provides backup electrical power for 1 hour in the case of main power source failure.

As a prototype airframe, Raytheon expects that there will be slight design changes based on the data collected from the initial test flights.

### Aircraft Registration:

This will be an Experimental Aircraft Registration.

Unless otherwise specified in the certificate, the aircraft will be marked on the aft fuselage surface using the N12345 format. 3" lettering will be used due to the small size of the aircraft. The word "Experimental" will be displayed on the fuselage over the wing in ½" letters.

**Aircraft Builder:**  
Raytheon Missile Systems

**Year Manufactured:**  
2006

**Aircraft Serial Number:**  
Serial Number 006  
(Update serial number for each application)

**Aircraft Registration Number:**  
N606RN

**Aircraft Model Designation:**  
Cobra

**Engine Model:**  
Desert Aircraft DA-150  
[http://www.desertaircraft.com/engines\\_detail.php?Page=DA-150](http://www.desertaircraft.com/engines_detail.php?Page=DA-150)

**Fuel:**  
87-91 Octane Gasoline  
OR  
100 Octane Aviation Fuel

**Oil:**  
Saber™ Professional Synthetic 100:1 Pre-Mix 2-Cycle Oil (ATP)  
<http://www.amsoil.com/storefront/atp.aspx>

**Propeller Model:**  
Mejzlik 28 x 12 -3b; 28 x 12 W-3b; 30 x 12  
<http://mejzlikmodellbau.inshop.cz>

Air Models 28 x 12 -3b

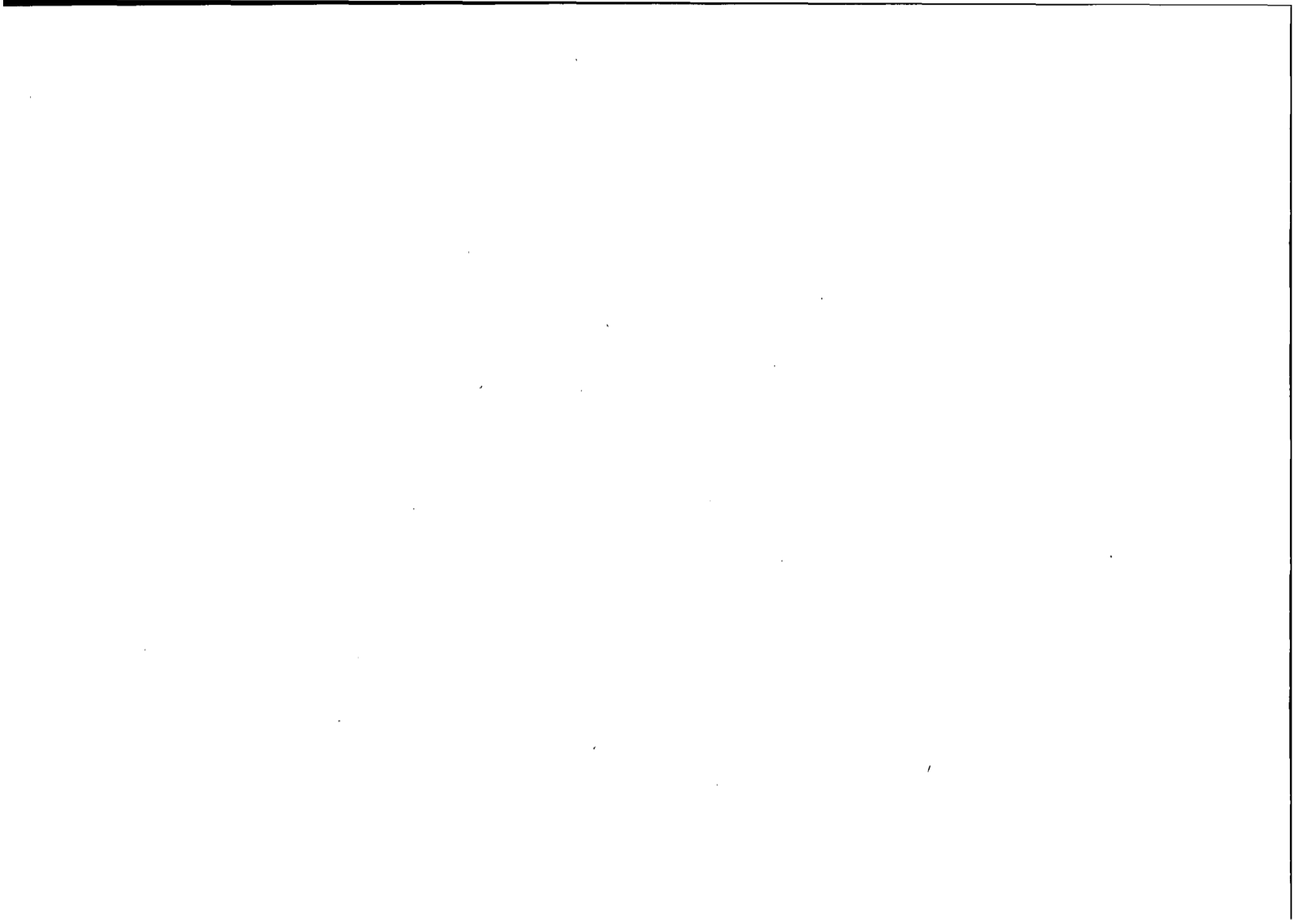

# Raytheon

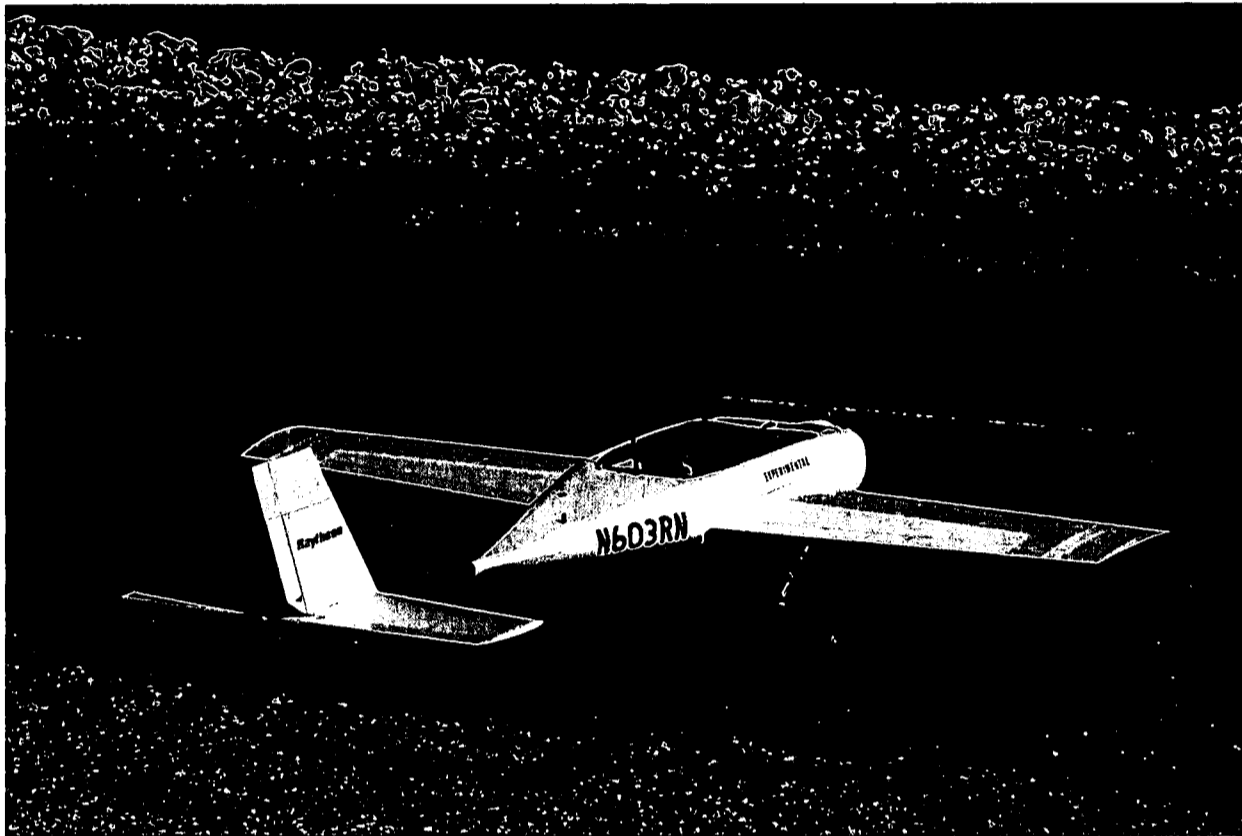

Figure: 1 Cobra UAS

**1. Define the experimental purpose(s) under which the aircraft is to be operated (14 CFR § 21.191)**

*Research and development.* Testing new unmanned aircraft design concepts, avionics and ground equipment, Command and Control Systems, installations, operating techniques, and new uses for unmanned aircraft.

*Crew training.* Training of the Raytheon Company flight crews.

*Market surveys.* Use of UAS for purposes of conducting market surveys, sales demonstrations, and customer crew training only as provided in §21.195.

**2. Describe the purpose/scope of the experimental program for each 14 CFR § 21.191 experimental purpose sought (14 CFR § 21.193(b)(d))**

*Research and development* – This unmanned aircraft will be used as a test bed for data links, sensors, processors, autopilots, “sense and avoid” and other electronics/avionics as required to meet the Raytheon Company business goals.

*Crew training* – Flights will be conducted by qualified Raytheon UAS pilots. Aircraft checkout and regular proficiency training will be conducted to meet the Raytheon

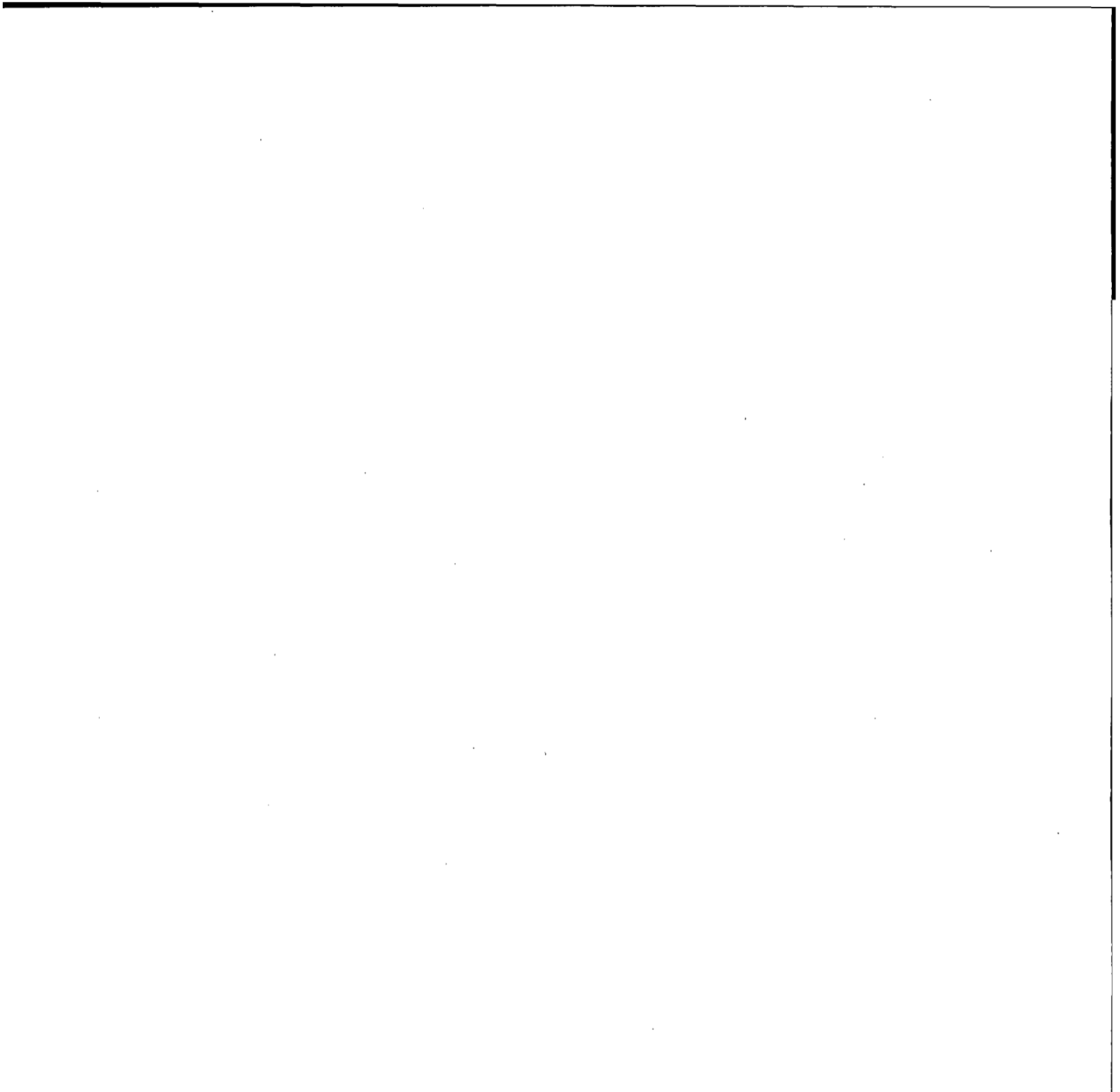

# Raytheon

Company flight testing requirements. Upon customer request, flight training of a customer pilot will occur.

A training program will be submitted as a separate document.

*Market surveys* – This aircraft will be used to demonstrate the concepts, electronics and avionics listed above to various public customers. The demonstration of the Cobra UAS will only be conducted at the site approved under the experimental airworthiness certificate.

### **3. Define the area(s) in which the experimental flights will be conducted**

- Describe the areas over which the flights are to be conducted and address of base operation (14 CFR § 21.193(d)(3)).

#### **SOUTHERN ARIZONA**

Raytheon leases a new facility built specifically by Unmanned Vehicles International (UVI) Inc. (<http://www.uviinc.com/>) to operate UAS near Sierra Vista, AZ.

Unmanned Vehicles International, Inc  
633 Wilcox Drive  
Sierra Vista, Arizona 85635  
520-458-4212

Raytheon has been using this facility for local UAS operations since April 2005, and has accumulated 119 hours from 200 flights using the Manta, Silver Fox, and Cobra UAS.

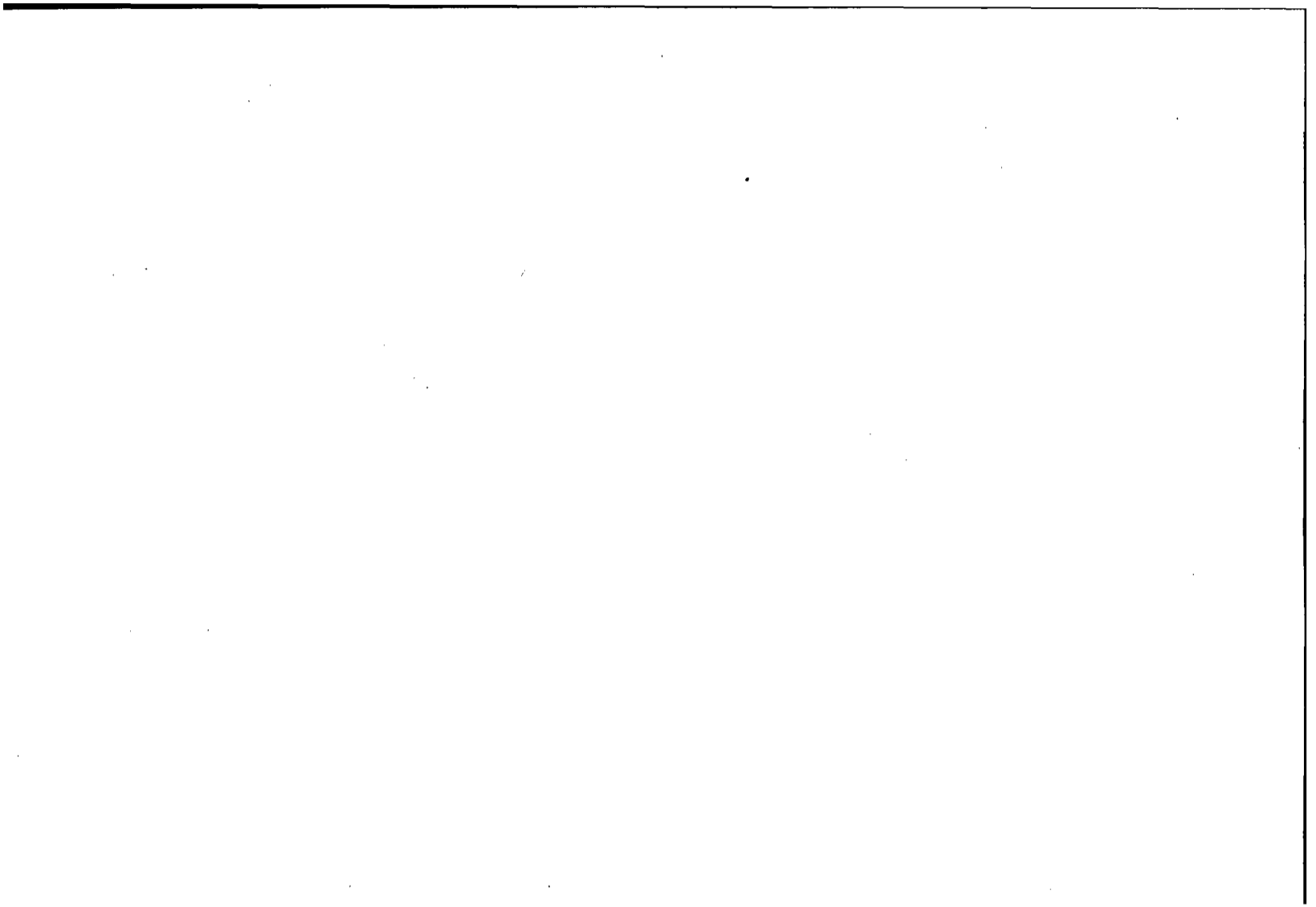



# Raytheon

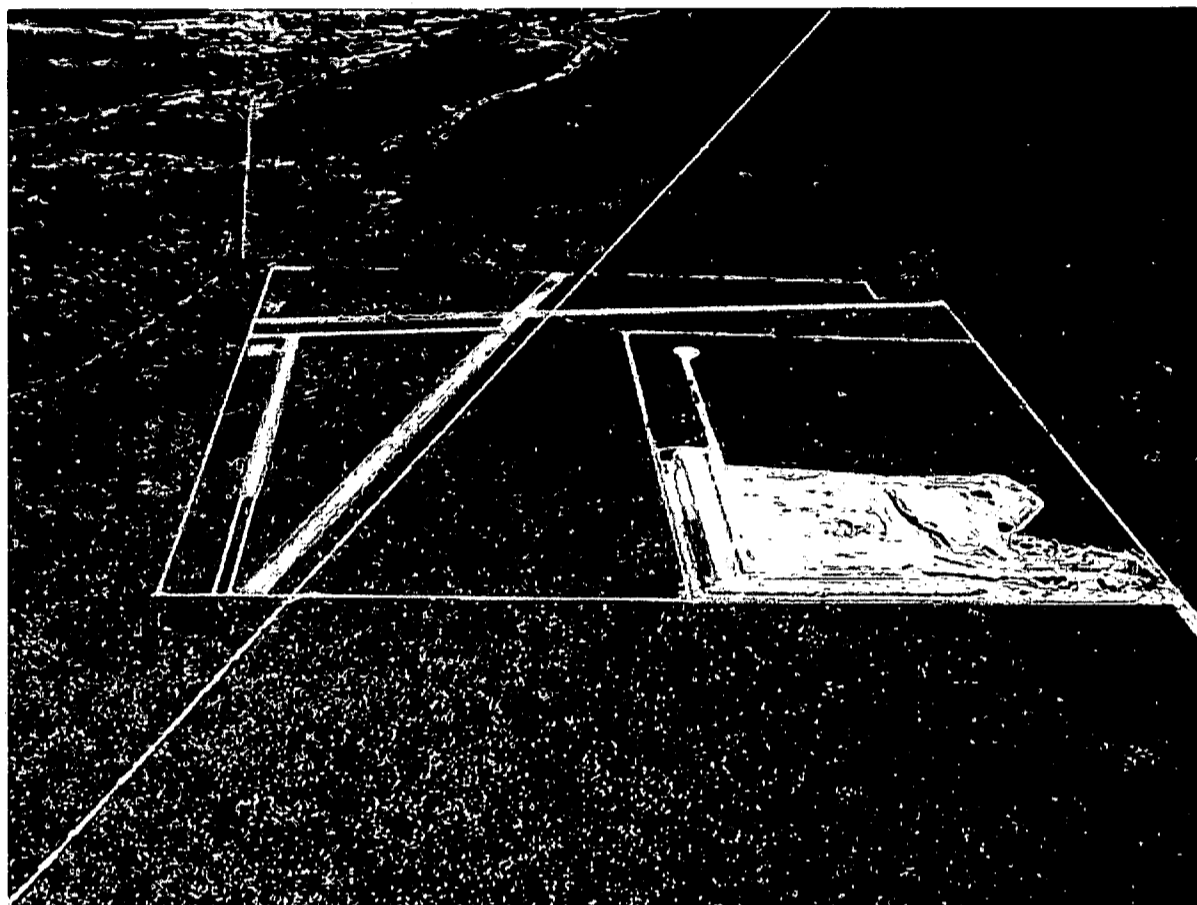

Figure: 2 UVI Airfield

UVI UAS airfield looking north, located next to the Cochise County landfill.

Phoenix Sectional

FHU 004/08.5, 4225' Elevation

N 31° 43' 30", W 110° 17' 47"

The UVI site is shown in Figure 2 and was specifically located to have easy access to the R-2303 restricted airspace. Not having regular access to the restricted airspace, Raytheon will operate below the 8000' MSL lower limit of R-2303B to remain outside of restricted airspace unless prior coordination has been obtained. The pattern altitude is 700' AGL. When not landing, Raytheon would operate at 2000' AGL and below, normally remaining between 1500' and 2000' AGL. As a civil user not on a DoD contract, Raytheon does not have priority access to the R-2303 airspace. Through UVI Inc, Raytheon has coordinated with the Libby Field Airspace Manager, El Paso Gas (pipeline patrol) and the Border Patrol, and has directly coordinated with Prescott Flight Service Station for NOTAMs. NOTAMs will be filed as directed by the FAA.

The Four Pillars (AZ21) airfield indicated in red on the map shown in Figure 3 is currently abandoned.

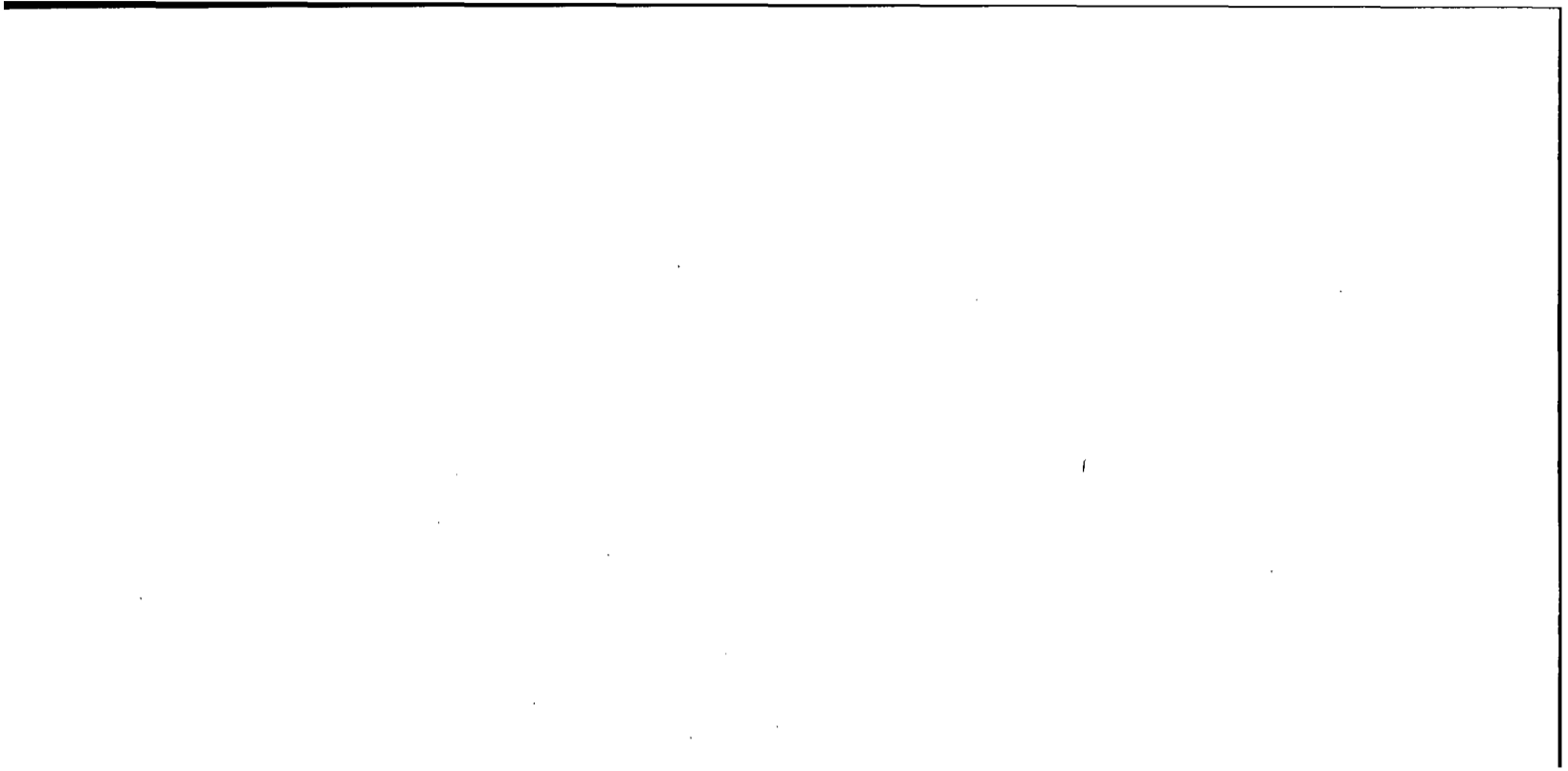

## **Raytheon**

The UVI site is located on state property and is operated on a state lease for the purpose of operating UAS. The State has approved the lease to UVI Inc for UAS operations only. From Highway 82 to the south to I-10 on the north, the land is nearly uninhabited. The only ground traffic in the proposed operating area is along Highway 80 from Tombstone to Benson.

The Raytheon local operating area is a 1 mile radius from UVI and the aircraft are kept north of Highway 82 and east of Highway 90. When flight operations will remain within 1 NM and the Ground Observer will be able to maintain visual contact, and a chase plane will not be used.

In Figure 3, the larger area outlined with a hashed red line is the proposed Raytheon UAS containment area. This will be used for developmental testing and demonstration from the surface to 2000' AGL (6200' MSL average). All of Raytheon's UAS flight operations will be within radio line of sight of the Ground Control Station. Victor Airway 66 crosses the proposed operating area and has a Minimum Reception Altitude (MRA) of 9500' MSL (4500' AGL). VR 259 from points D to E, and VR 260 from points D to E, also cross this area, and Raytheon will contact Flight Service to see if they are active prior to crossing. For flights beyond visual range of the Ground Observer, a chase plane will be used. The chase plane and UAS will have active transponders when within the lateral limits of the VR routes.

The class E airspace overlaying the proposed operating area is used for instrument approaches into Libby Army Airfield (KFHU). The TOMBS intersection is the missed approach holding point at 9500' MSL, and the minimum vectoring altitude is 6500' MSL for IFR traffic. Raytheon reports operations to Libby Approach and monitors the approach control frequency during flight. By agreement with Libby Radar, Raytheon squawks 1202 mode C to differentiate from other VFR traffic.

Ninety Percent of the proposed operating area is uninhabited state land. The cutouts at the corners of the proposed op area are designed to keep Raytheon UAS away from the small communities of Whetstone to the SW, St David to the north, and Tombstone to the SE. The eastern border is the edge of the Tombstone MOA. State highway 90 borders the western edge, state highway 82 the southern edge. The only trafficable road inside the op area is state highway 80, a two lane blacktop between Benson and Tombstone. The San Pedro river valley traverses the area south to north, and is a designated wildlife area. All flight operations over the wildlife area will be 2000' AGL or above.

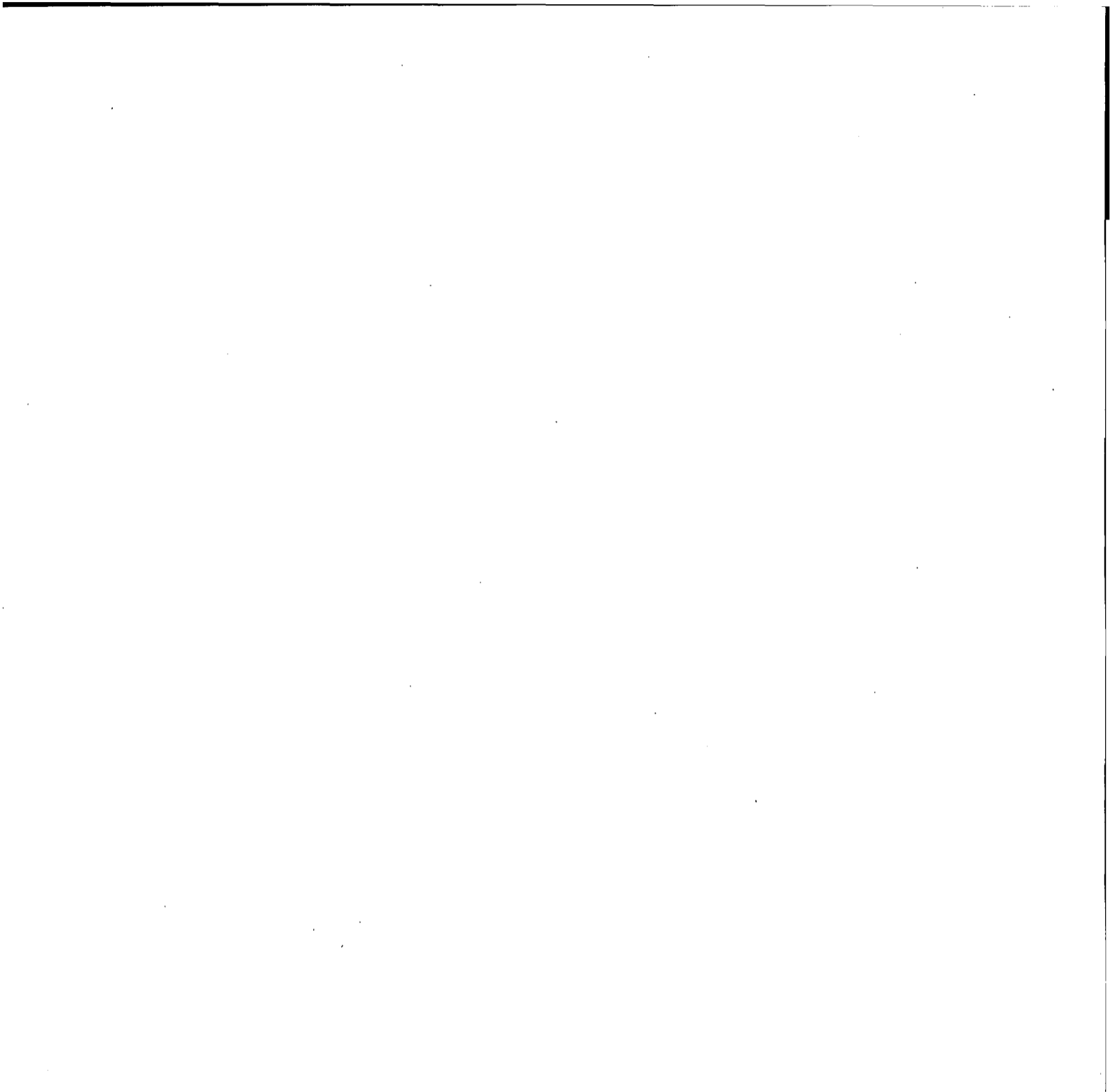

# Raytheon

- Identify all proposed flight areas using latitude and longitude on aeronautical maps.

The following grid coordinates define the Raytheon Op Area:

1. N 31° 44' 00.00" W 110° 20' 30.00"
2. N 31° 52' 00.00" W 110° 20' 00.00"
3. N 31° 52' 00.00" W 110° 11' 00.00"
4. N 31° 56' 30.00" W 110° 11' 00.00"
5. N 31° 58' 10.00" W 110° 03' 00.00"
6. N 31° 50' 30.00" W 110° 03' 00.00"
7. N 31° 50' 30.00" W 110° 00' 00.00"
8. N 31° 45' 00.00" W 110° 00' 00.00"
9. N 31° 45' 00.00" W 110° 11' 00.00"
10. N 31° 43' 14.00" W 110° 14' 00.00"
11. N 31° 42' 00.00" W 110° 19' 30.00"
12. N 31° 44' 00.00" W 110° 19' 30.00"
13. Return to 1

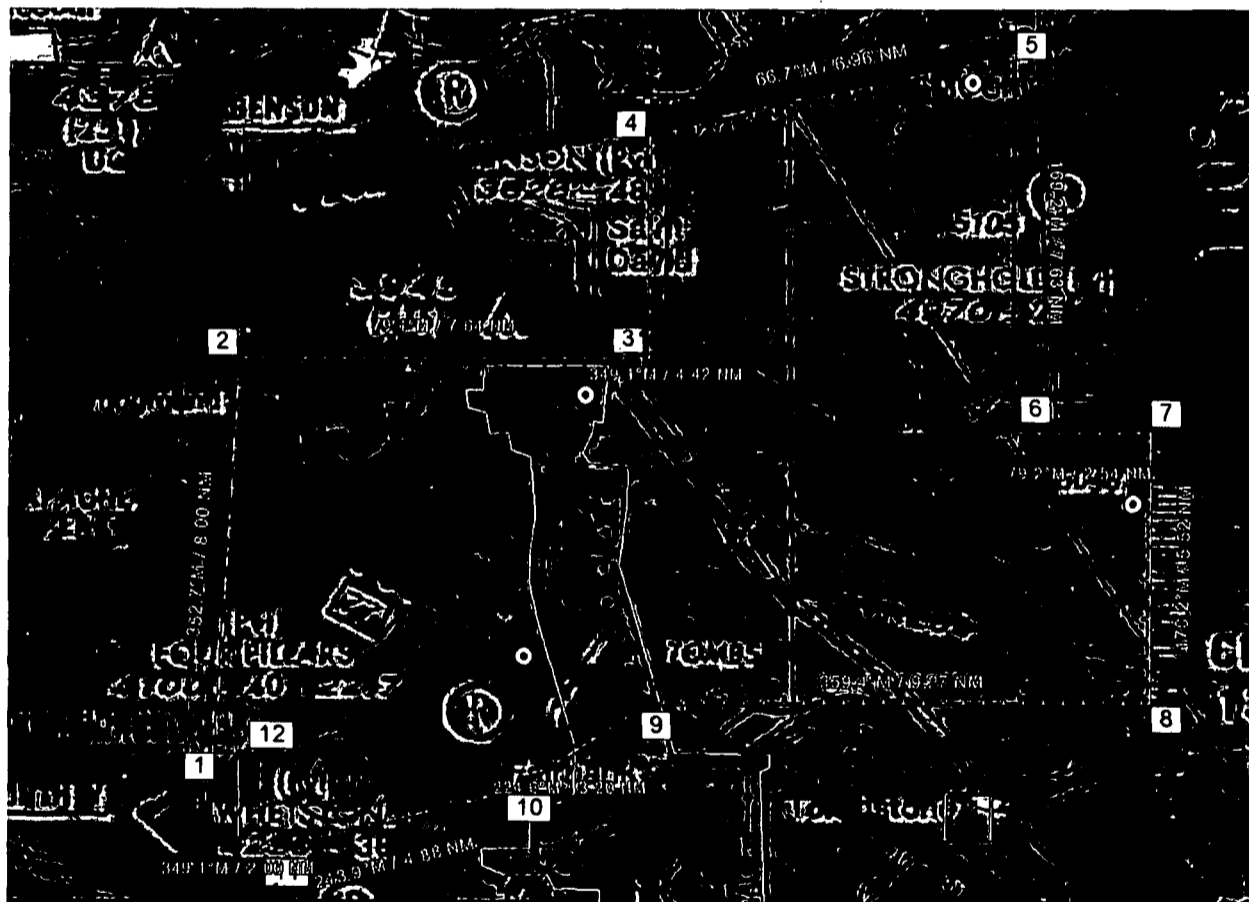

Figure: 3 UVI Containment Area

\_\_\_\_\_

\_\_\_\_\_

# Raytheon

- Include information on airspeed, altitude, number of flight hours, number of flights and program duration for each test flight area.

Airspeed: 35-100 KIAS

Altitude: 2000 AGL and below

Winds: 20 KTS headwind, 10 KTS crosswind

Flight Hours: 300 flight hours per year

2-3 flight days per week during the workweek. Weekend flying will occur only once per quarter.

Duration: 1 year for this application, with renewal annually.

- What class of airspace will be used?

FAA Class E and G.

- Will minimum fuel requirements of 14 CFR § 91.151 be met?

Yes, a fuel reserve minimum of 30 minutes for day flying will be maintained.

- Will flight-testing include payload testing?

Yes. Various Electro Optic, passive and RF sensors will be tested. Frequency management will be coordinated with the FAA, FCC Western Region and Fort Huachuca frequency managers.

- What considerations need to be taken with regard to Payloads?

Considerations include size, weight, power requirements, EMI/RFI, drag, data communications and additional crew.

Size and weight of the payload will affect the aircraft weight and balance and maximum gross weight. The power draw on the onboard electrical system and backup batteries must also be considered. EMI/RFI might affect the aircraft as well as the payload. If the payload is external or has external components such as antennae, the drag increase must be evaluated. If the payload requires additional data communications, the effect on the available bandwidth and data priority as compared to command and control data will be evaluated. The addition of a payload will affect the workload of the crew depending on its complexity. The workload will be evaluated and an additional crew member added if required to operate the sensor. The addition of flight crewmembers or additional training will be considered when required for new payload operations.

- Will the aircraft perform any aerobatic maneuvers?

No

- Flight Conditions (e.g., VFR, IFR, VMC, etc.)

Day VFR only. All testing, training and demonstration will be conducted in Day VFR conditions.

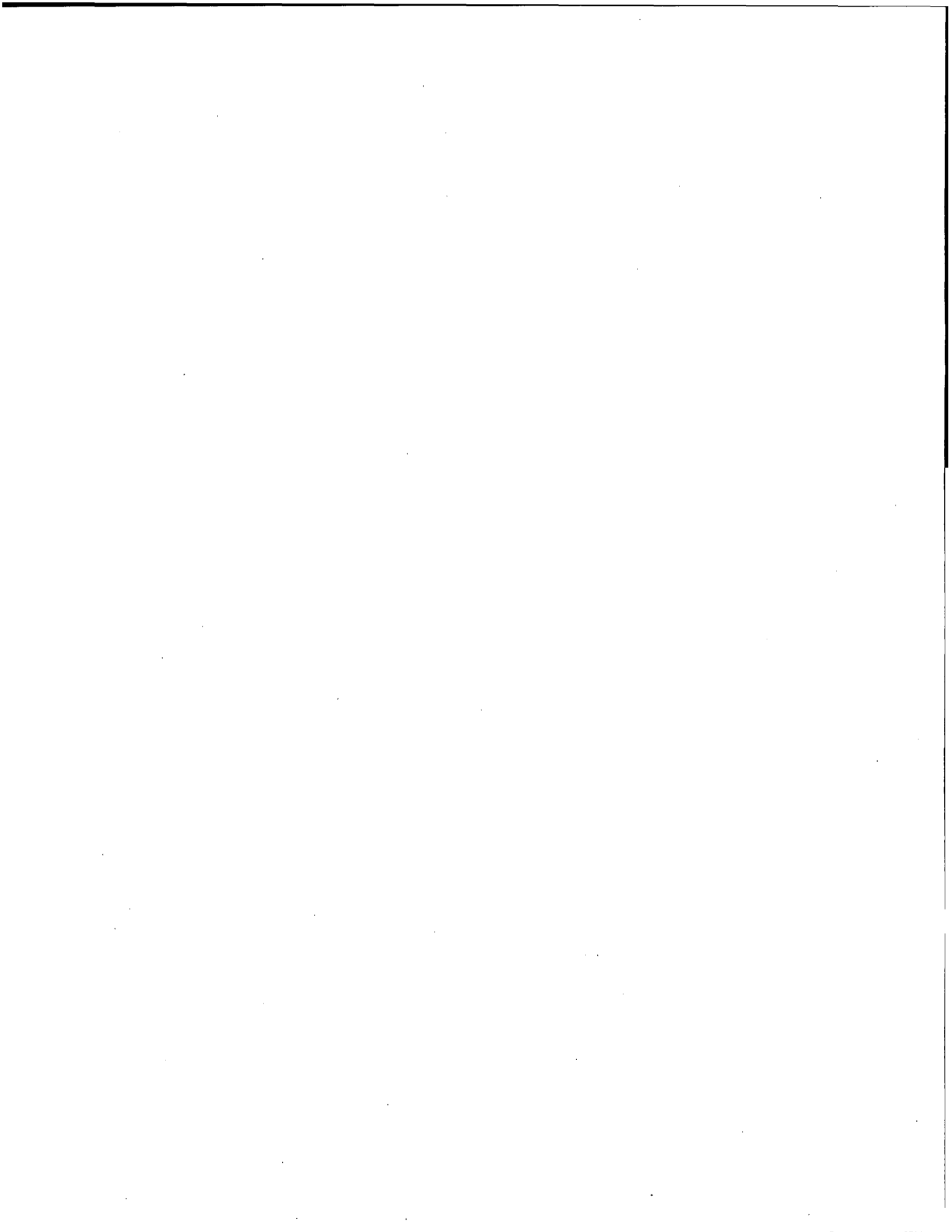



# Raytheon

## UNITED STATES AIR FORCE ACADEMY

United States Air Force Academy  
2346 Academy Dr, Colorado Springs, CO 80840

The United States Air Force Academy has defined a Small UAS operating area in the northwest corner of the base in accordance with the FAA DoD MOU. The Cobra UAS Demo will utilize a subset of this area and operate within 1 NM from the landing strip.

The pattern altitude is 600' AGL and flight outside the landing pattern will be 2000' AGL and below. Raytheon has coordinated with the USAFA airfield manager and the FAA DoD area representative. NOTAMs will be filed as directed by the FAA. Raytheon will monitor KAFF tower frequency during the demonstrations.

The center of the landing area is at N 39° 01' 02.54", W 104° 53' 30.79"

Denver Sectional

Black Forrest VORTAC (BRK) 280.6/12.87

The demonstration will occur at a large athletic field complex which is north of the main campus. The specific site is within Alert Area A260, but outside of KAFF Class D and Colorado Springs Class E airspace. The containment area is completely within the AFA Base Boundary. The runway is a 1400' macadam strip oriented N/S between two athletic fields with an elevation of 7060'.

The Airway V108 passes over the Alert Area with a base at 16000' MSL

Figure 4 shows the Containment Area, the landing pattern and runway. The USAFA will control ground access and limit USAF aircraft overflight during the demonstration.

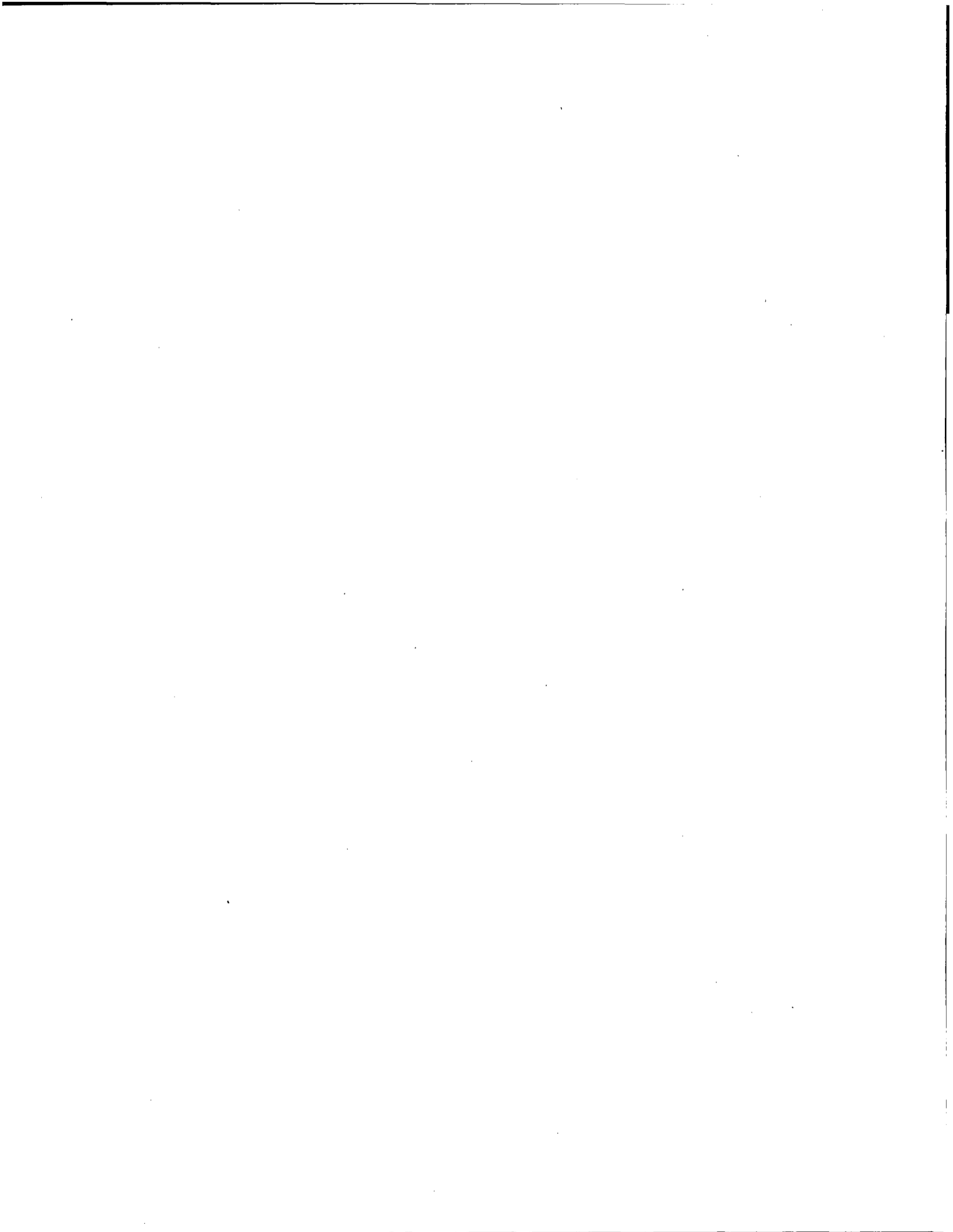

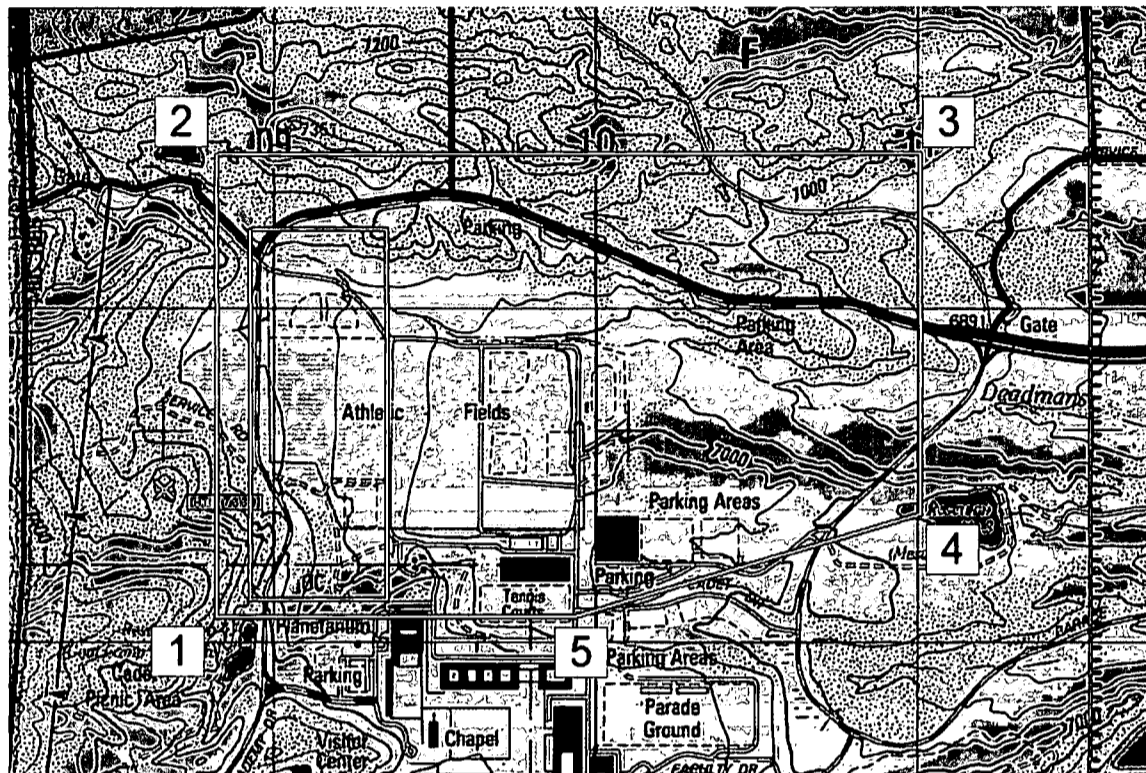

Figure: 2 USAFA Cobra UAS Demo

- Identify all proposed flight areas using latitude and longitude on aeronautical maps.

The following grid coordinates define the AFA Cobra Demo containment area:

1. N 39° 00' 42.00" W 104° 53' 53.00"
2. N 39° 01' 27.00" W 104° 53' 53.00" 0.7NM/0°
3. N 39° 01' 27.00" W 104° 52' 22.00" 1.2NM/90°
4. N 39° 00' 52.00" W 104° 52' 22.00" 0.6NM/180°
5. N 39° 00' 42.00" W 104° 53' 07.00" 0.6NM/254°
1. N 39° 00' 42.00" W 104° 53' 53.00" 0.6NM/270°

In Figure 5 below, the containment area is the very small yellow box in the northwest corner of Alert Area 260. The dark blue line is the AFA Base Boundary. The light blue hashed line defines Alert Area 260. The red line shows the center of Victor Airway 108. The purple hashed line defines the Colorado Springs Class C/E airspace.

\_\_\_\_\_

\_\_\_\_\_

\_\_\_\_\_

---

# Raytheon

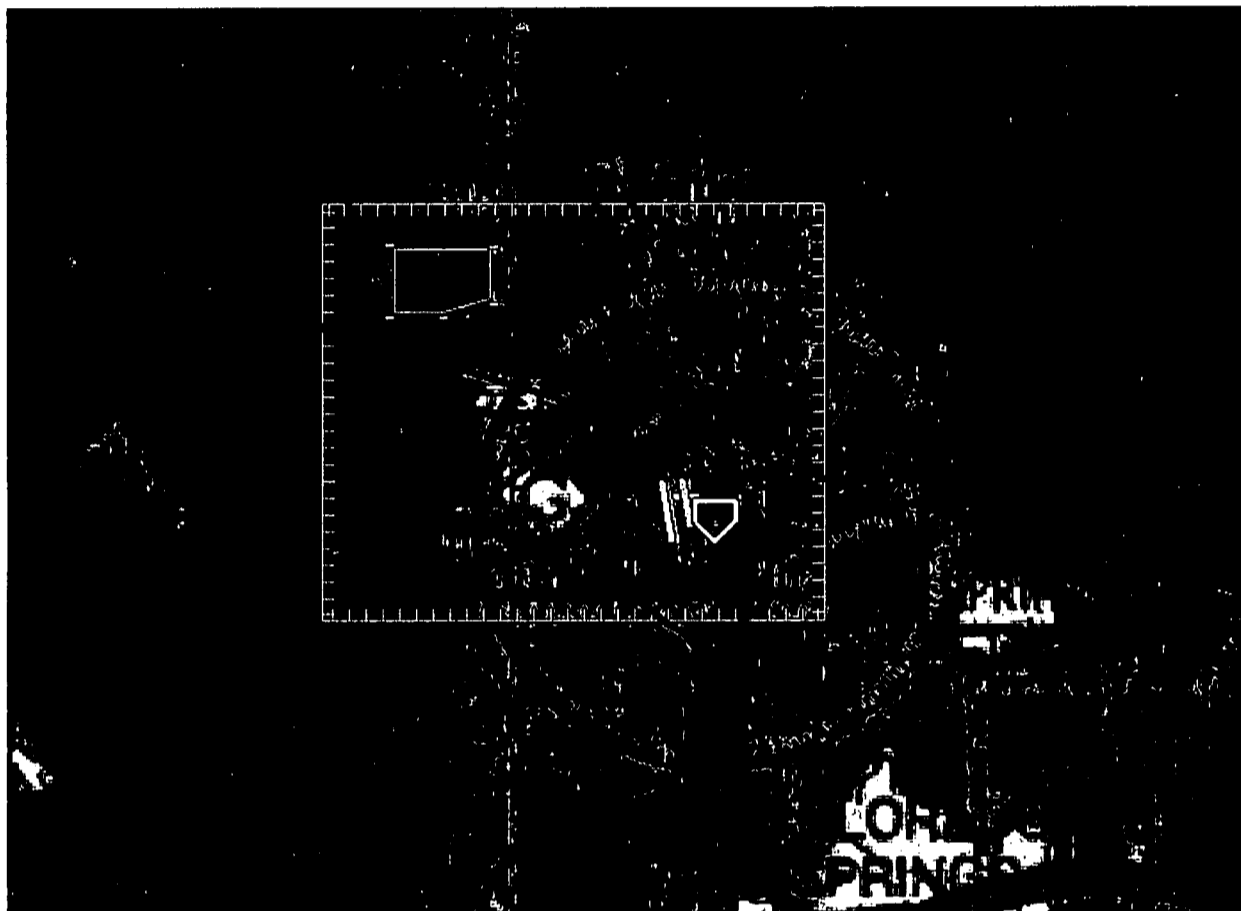

Figure: 5 USAFA Containment Area

- Include information on airspeed, altitude, number of flight hours, number of flights and program duration for each test flight area.

Airspeed: 35-100 KIAS

Altitude: 2000 AGL and below

Winds: 20 KTS headwind, 10 KTS crosswind

Flight Hours: 4 hours per day during the demonstration periods

Duration: 1 year with short duration demonstration or testing periods

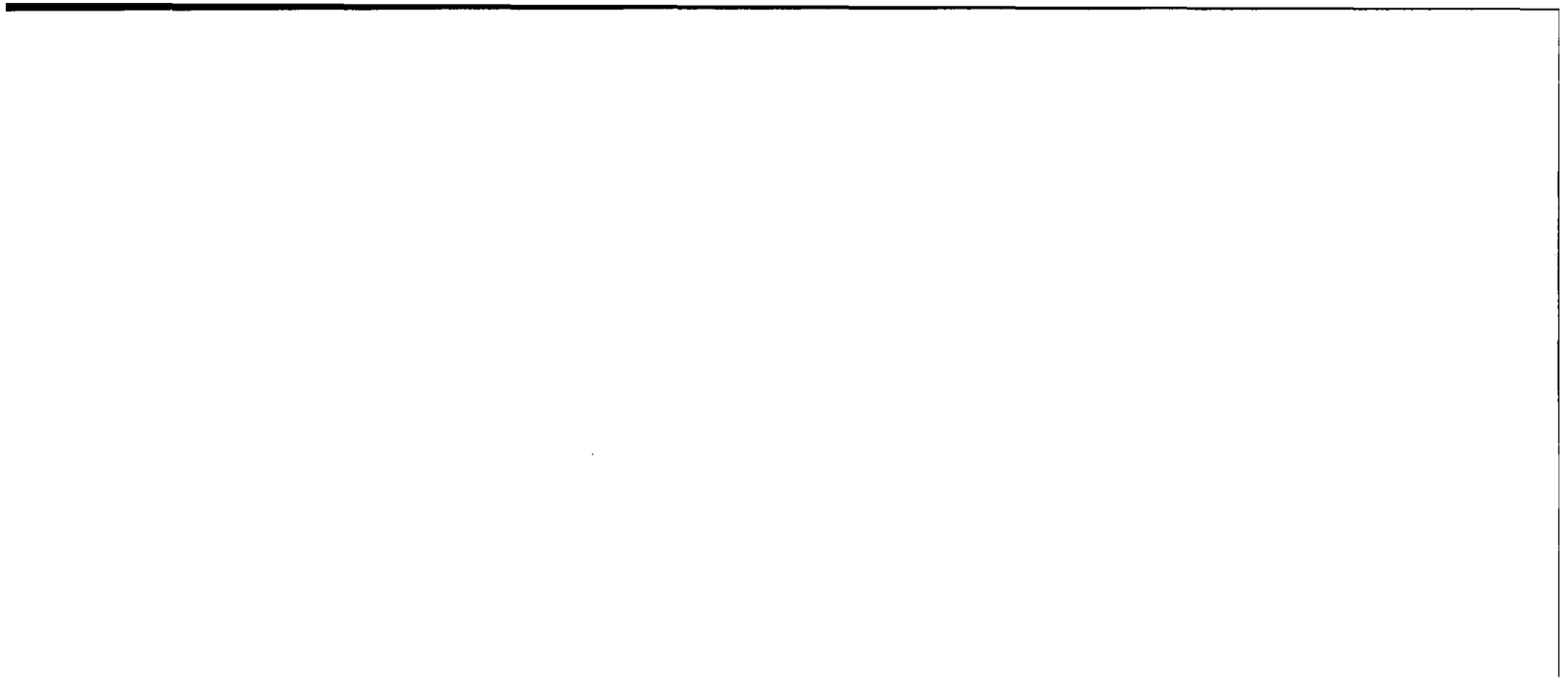

# Raytheon

- What class of airspace will be used?  
FAA Class G and Alert Area 260
- Will minimum fuel requirements of 14 CFR § 91.151 be met?  
Yes, a fuel reserve minimum of 30 minutes for day flying will be maintained.
- Will flight-testing include payload testing?  
Yes. Various Electro Optic, passive and RF sensors will be tested. Frequency management will be coordinated with the FAA, FCC Western Region and Fort Huachuca frequency managers.
- What considerations need to be taken with regard to Payloads?  
Considerations include size, weight, power requirements, EMI, RFI, drag, data communications and additional crew.  
  
Size and weight of the payload will affect the aircraft weight and balance and maximum gross weight. The power draw on the onboard electrical system and backup batteries must also be considered. EMI/RFI might affect the aircraft as well as the payload. If the payload is external or has external components such as antennae, the drag increase must be evaluated. If the payload requires additional data communications, the effect on the available bandwidth and data priority as compared to command and control data will be evaluated. The addition of a payload will affect the workload of the crew depending on its complexity. The workload will be evaluated and an additional crew member added if required to operate the sensor. The addition of flight crewmembers or additional training will be considered when required for new payload operations.
- Will the aircraft perform any aerobatic maneuvers?  
No
- Flight Conditions (e.g., VFR, IFR, VMC, etc.)  
Day VFR only. All testing, training and demonstration will be conducted in Day VFR conditions.

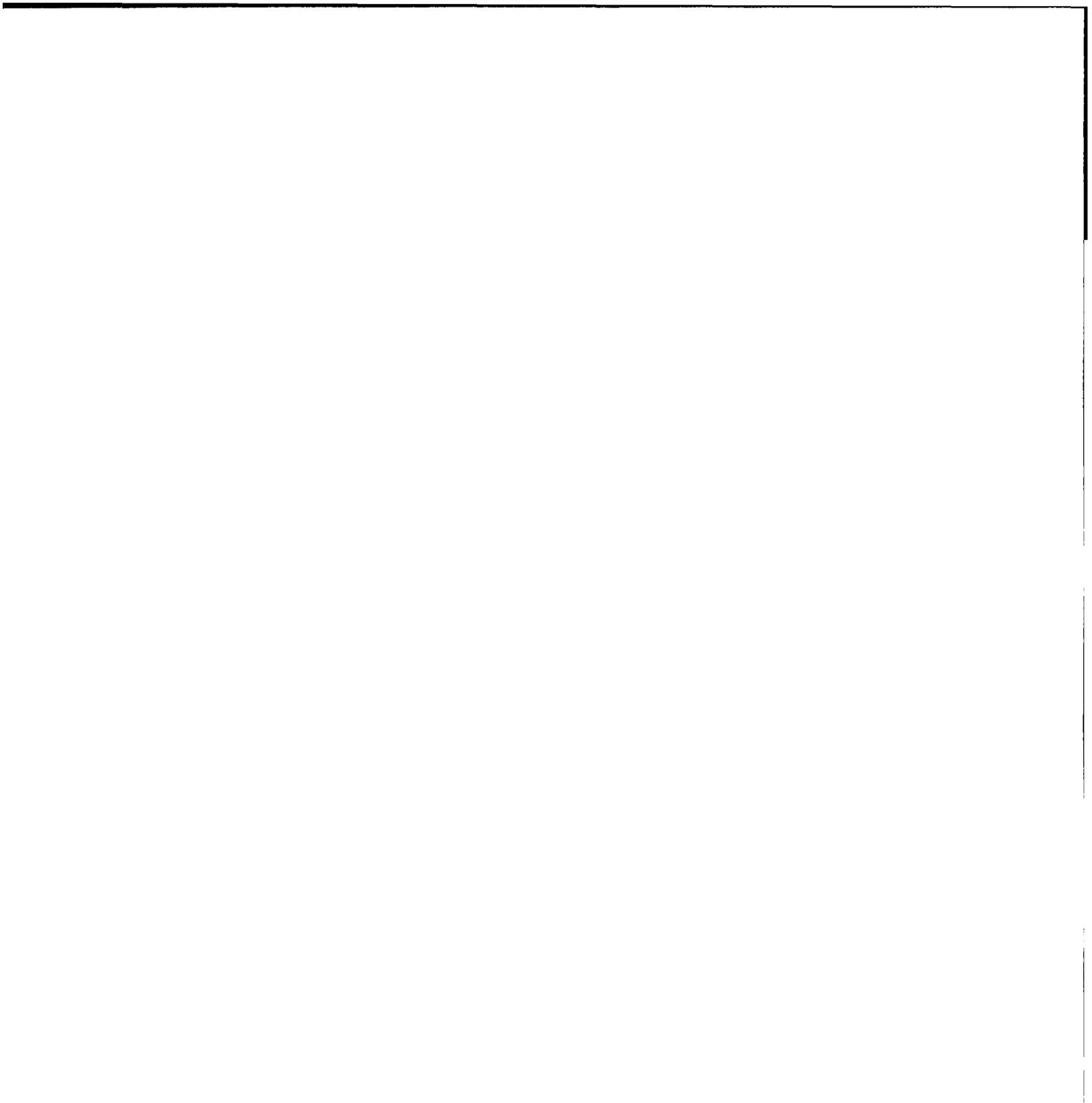



## 4. Aircraft Configuration

- Attach three-view drawings or three-view dimensioned photographs of the aircraft (14 CFR § 21.193(b) (4)). (Appendix A)

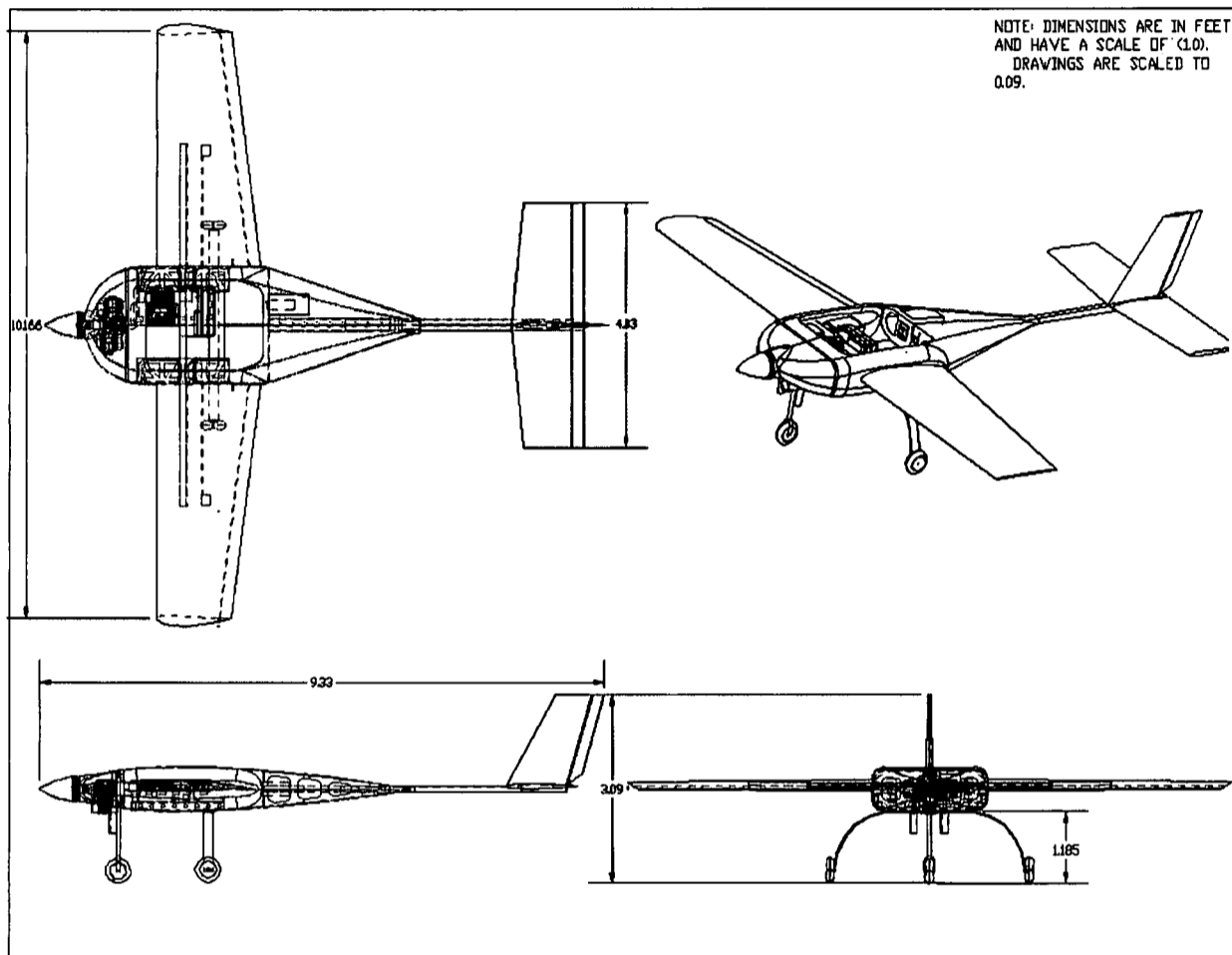
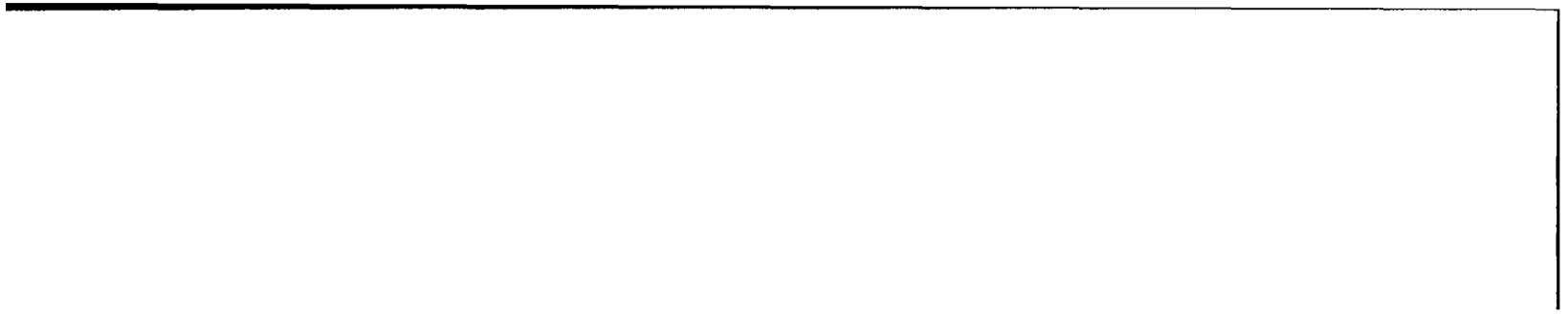

Figure: 6 Cobra 3 View Drawing

- Describe Unmanned Aircraft System configuration including ground control station.
  - Cobra UAS
    - Cloud Cap Piccolo II Autopilot (<http://www.cloudcaptech.com/>)  
See Appendix B – Piccolo Systems Users Guide  
The Piccolo II is a MEMS based autopilot that allows for manual, stability augmentation, and autonomous control of the UAS. The air data system, GPS, and Microhard datalink are built into a compact, low weight, avionics package. A Honeywell magnetometer provides magnetic heading information to the autopilot.
    - DGPS (<http://www.novatel.com/products/flexpak.htm>)



---

# Raytheon

A Novatel FlexPak-G2L DGPS provides centimeter level accuracy for Autonomous takeoff and landing operations.

- Transponder

Microair 2000, mode 3a/c with air data provided by an altitude encoder or the Piccolo II flight control system.

The transponder will be required for all flights.

- Lights

A white strobe light will be attached to the upper fuselage as an anti-collision light for all flights.

- Video Transmitter

An independent COTS ¼ to 3 watt video transmitter at 2.4 GHz will be used for transmission of the video signal.

- Power

Primary electrical power comes from a 500 watt generator with a 180 watt regulator. A Lithium Polymer rechargeable battery provides backup electrical power for 1 hour in the case of main power source failure. The battery is charged in flight.

The system voltage is indicated to the pilot as well as a visual and audio alert if the high or low voltage range is exceeded. While on Generator power (14.8 volts) the voltage is green. If the generator fails, the battery (15.8 volts) comes online and the alert sounds. Once the battery is below 14.8 volts the alert will stop until the low voltage value is exceeded.

- Datalink

- Microhard MHX UHF Datalink

The Piccolo autopilot has an integrated MHX-910 frequency hopping radio from Microhard Systems Inc. The MHX radio is a 900MHz ISM band radio with good receive sensitivity and a maximum 1 Watt output power. The wireless link formed between radios extends from all the aircraft to the ground station. Traditional wireless links were made of a single frequency, and multiple networks could be constructed by using multiple frequencies. With a frequency hopping radio the concept of networks defined by frequencies is replaced with networks defined by hopping patterns. Hence it is possible to have a network of radios using one hopping pattern while another network of nearby radios uses a separate hopping pattern. In each case a single ground station coordinates the communications for each network.

The Microhard radio has a 25 NM range and is used as the Primary control link when installed alone or as the secondary link and flight termination system if a developmental datalink is installed.

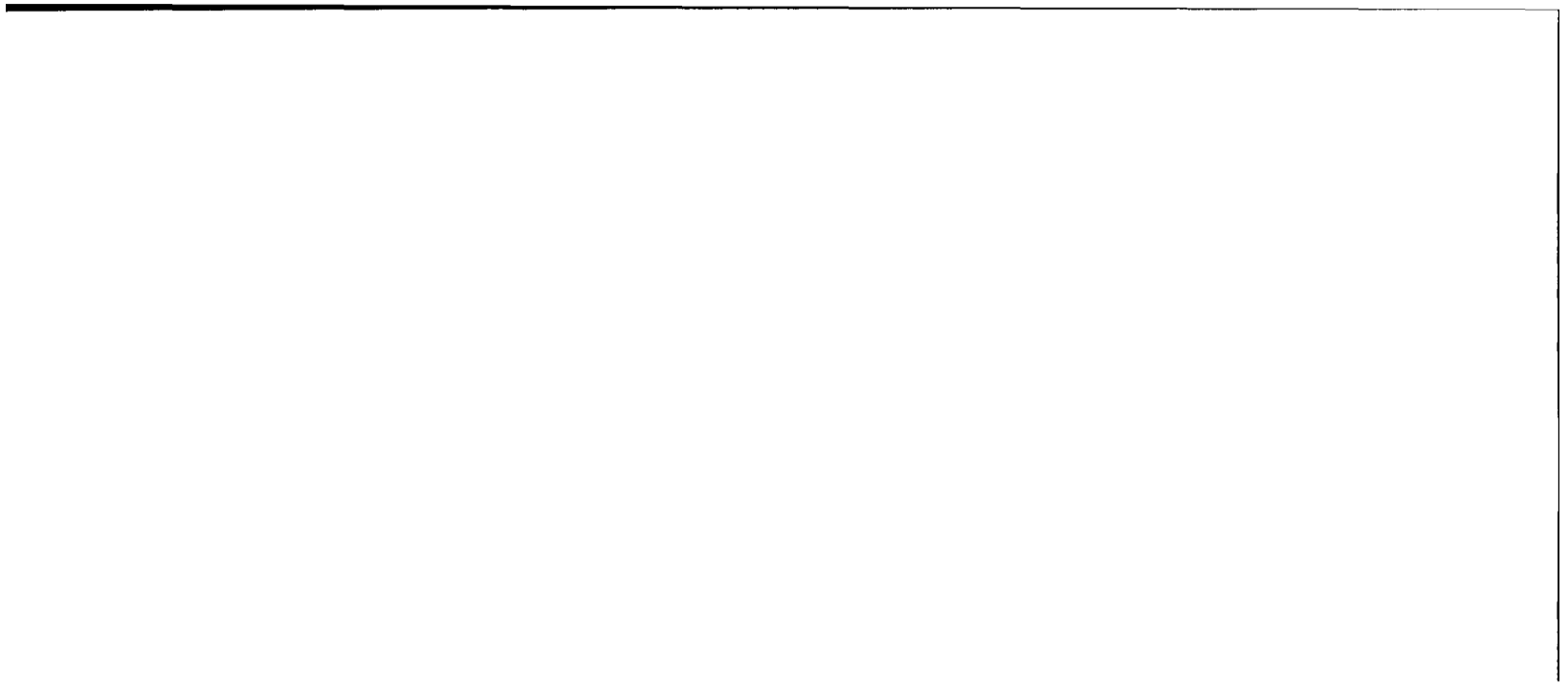

# Raytheon

- Raytheon MicroLight UHF Datalink

The MicroLight radio is based on the Raytheon Enhanced Position Location Reporting System (EPLRS) technology. This is a software programmable digital datalink operating from 420-450 MHz. This radio is networkable, allowing the radio to act as a node in a network. This radio has a 100 NM range. The range is variable with the selected mode of operation.

The MicroLight UHF Datalink is developmental and can be used for C2 and low rate video. This radio will be evaluated for Joint Tactical Radio System (JTRS) waveforms, and its usability within a net-centric UAS.

- Other developmental datalinks (See Proprietary Payload Addendum)

For all datalink testing, the original MicroHard link provided with the Piccolo II autopilot will be maintained as a secondary safety backup and flight termination system.

- Ground Control Station

- Raytheon Multi-Vehicle Control System (MVCS)

The MVCS is a derivative of the US Navy Tactical Control System and can be used to control different types of UAS as long as a STANAG compliant Vehicle Specific Module (VSM) has been created for that aircraft. STANAG 4586 is a NATO standard for interoperability between diverse UAS. The MVCS is networkable allowing multiple pilot consoles to be connected together and to share data. MVCS is also designed to be hosted on the Digital Common Ground Station (DCGS) developed by the US Air Force.

- STANAG 4586 Vehicle Specific Module (VSM)

The VSM is the interface or translator between the aircraft and the ground control station. It is software, and can be hosted on an airborne processor in the aircraft or the computer connected to the Ground Control Station. The VSM used by the Cobra is the same as that used on the Manta and Silver Fox UAS. The VSM interface for these aircraft was created to communicate with the Piccolo autopilot.

- STANAG 4586 Common UAV Control Station (CUCS)

The CUCS is the operator interface to the system controls. It provides the displays of information to the Pilot (Figure 7). The displays are configurable and can be considered a virtual Multi-Function Display (MFD). The displays include the Primary Flight Display (PFD), a moving map or situational awareness display, Warnings and Cautions, and various data displays for the aircraft telemetry. This system allows satellite imagery to be used as a



moving map display. When more than one UAS telemetry stream is detected on the network, all UAS positions are shown on the map with an ID and altitude tag.

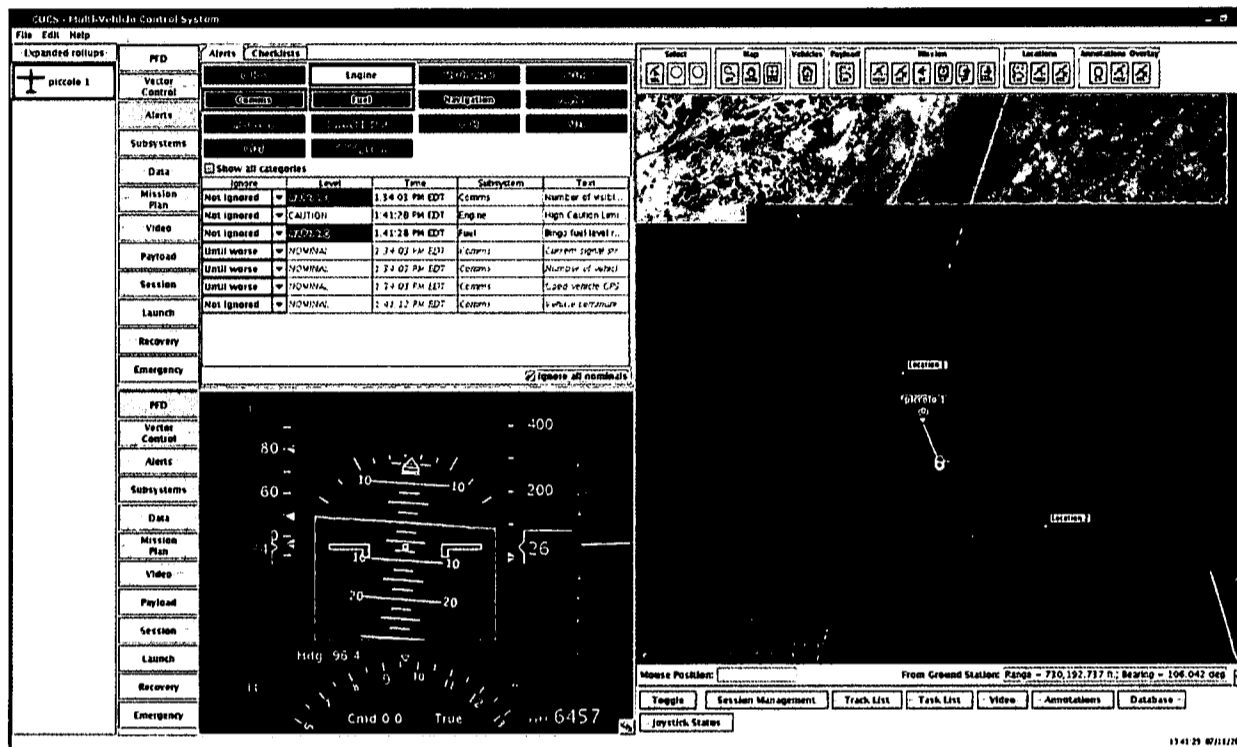
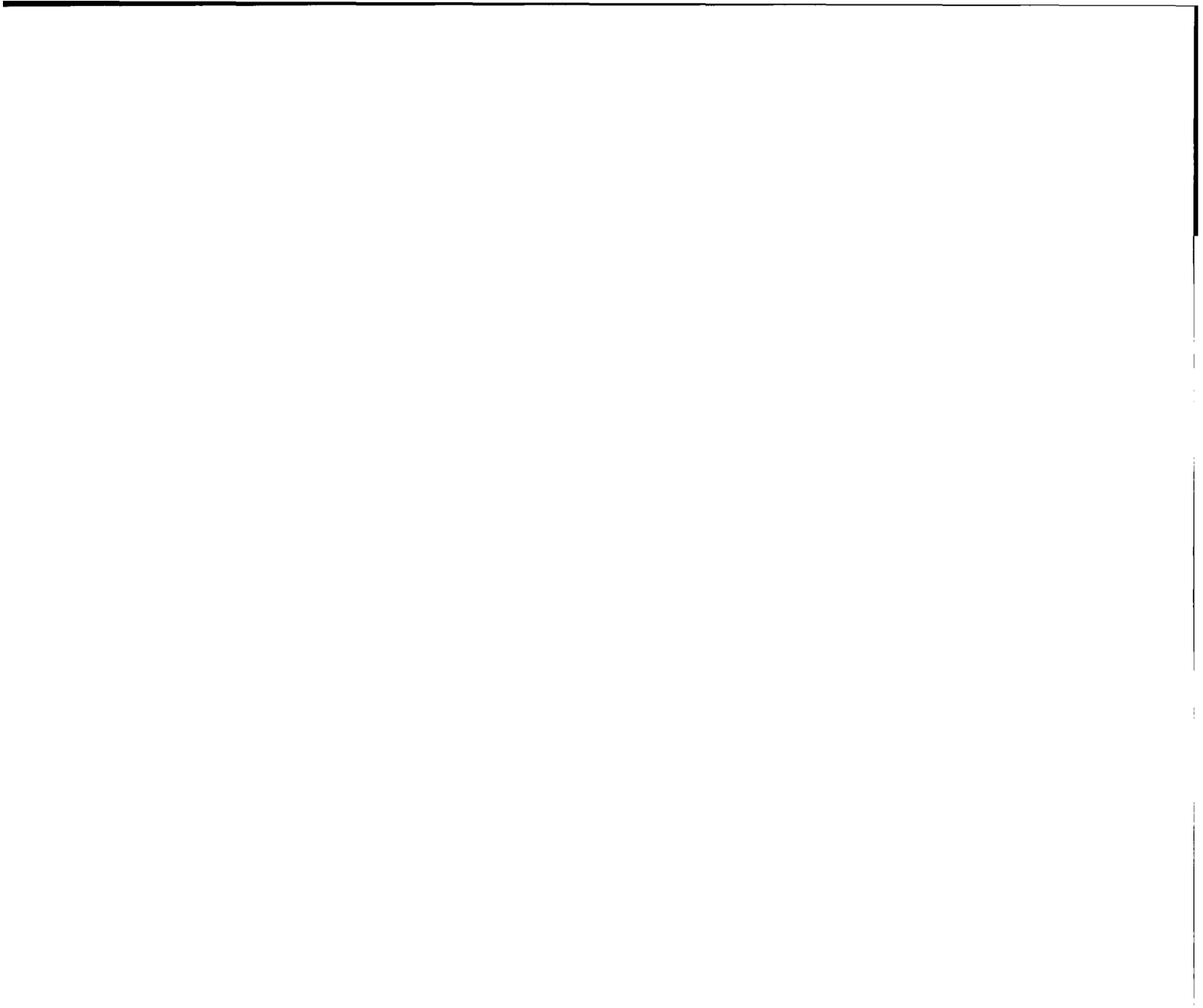

Figure: 7 MVCS CUCS

- Cloud Cap Piccolo Operator Interface
  - See Appendix B – Piccolo Systems Users Guide. The Piccolo Operators Interface can be used as a stand alone or in concert with the MVCS. Often it is used for preflight and launch/recovery while the MVCS is used for cruise flight. This allows multiple pilots to manage multiple aircraft from a series of networked pilot consoles.
- Payloads
  - See Proprietary Addendum
- Include a description of aircraft/system performance characteristics:
  - Wing span: 10.166 FT.
  - Length: 9.33 FT.
  - Power Plant: Desert Aircraft, DA-150, 16 HP, Air Cooled, Two-Cylinder Opposed, 2 Stroke Gasoline Engine
  - Max Gross Take Off Weight: 115 LBS
  - Fuel capacity: 4.0 GAL, 87-100 Octane with 100:1 oil mix





---

# Raytheon

- Payload Capacity: 30.0 LBS
- Max altitude: 15,000 FT. MSL
- Endurance: 4 hours
- Max airspeed: 95 KTS
- Wind Limitations: 20 KTS headwind 10 KTS crosswind
- Control/data frequencies: 420-450 MHz Primary, 902-928 MHz Secondary
- Guidance and navigation control: Cloud Cap Technologies Piccolo II Autopilot
- Flight termination frequencies, if any: 902-928 MHz. Raytheon uses the Microhard datalink as a flight termination device when developmental datalink is installed.

## 5. Inspection And Maintenance (14 CFR 91.7)

- Describe the inspection and maintenance program that will be used to maintain the aircraft and related systems (includes ground stations and/or other support systems).

See Raytheon Cobra UAS Inspection Plan

An aircraft logbook will be maintained on each aircraft, and a separate logbook for the ground control station. An engine log will be maintained for each engine as well.

The engines will be overhauled at 250 hours.

Discrepancies and maintenance actions will be noted in an electronic format used by Raytheon Integration and Test, and repairs will be made by Flight Test Team engineers. Preflight and postflight inspections will be conducted for all flights, as well as periodic inspections during integration and development.

An annual inspection will be conducted in accordance with the Cobra Inspection Plan.

Raytheon maintains a Test Readiness Review (TRR) process, where any changes to the configuration of the system must be approved by a board of senior engineers prior to testing. The status of all aircraft and any outstanding maintenance actions are reviewed at this time. Flight safety is the primary concern of the TRR.

- Provide copy of flight manual, if applicable, current weight and balance report, equipment list.

The Raytheon Cobra UAS Operations and Weight and Balance are included as appendix C and D.

The small size of the aircraft allows it to be weighed, and Center of Gravity (CG) calculations done prior to each flight. The data is collected and has been used to create a basic weight and balance calculator in a spreadsheet. The weight and cg envelope shows the limits of data collected to date. CG expansion tests will be conducted during aircraft performance testing.

A minimum equipment list is shown in Appendix E.

---

1

---

# Raytheon

## 6. Pilot Qualification (14 CFR §§ 61.3, 61.5)

- Describe the qualifications for each pilot.

See the Raytheon Cobra UAS Training Plan.

The Cobra requires a crew of 1 pilot. If required a Supplemental Pilot (SP) can assist the Pilot. The UAS pilot will be an FAA certified pilot for all flights, and shall be designated the Pilot in Command (PIC).

Pilot –FAA certified Private Pilot Airplane, physically and medically capable of completing all required tasks, and complete a UAS Practical Flight Test administered by the Raytheon Chief UAS Pilot or his designee. The Pilot must hold an FAA 3d class medical certificate.

Supplemental (External) Pilot (SP) – 3 Years previous RC Model experience with a similar aircraft or FAA certified Private Pilot Airplane, physically and medically capable of completing all required tasks, and complete a UAS Practical Flight Test administered by the Raytheon Chief UAS Pilot or his designee. The Supplemental Pilot must hold an FAA 3d class medical certificate and complete the FAA Private Pilot written test.

Observer - physically and medically capable of completing all required tasks, and approved by the Raytheon Chief UAS Pilot or his designee. The Observer must hold an FAA 3d class medical certificate and complete the FAA Private Pilot Written test.

The Pilot flies using the pilot computer console by reference to the Multi-Function Display, and other telemetry data, using the autopilot functions or the manual pilot console. The Pilot will take direction from Air Traffic Control or Observer to avoid other aircraft.

The PIC is responsible for the conduct of the flight, coordination, weather and preflight planning.

The Supplemental Pilot flies by visual reference using the manual pilot console. When in control, the SP will maneuver as required to avoid other aircraft. The SP cannot act as Observer when in control of the aircraft.

An observer will be assigned for all flights. He can be on the ground or in the chase aircraft.

An example of the Raytheon pilot qualifications are listed below:

### Chief UAS Pilot

Certified Flight Instructor-Airplane, Commercial Instrument ASEL, AMEL, Commercial Glider, Commercial Helicopter, Airframe and Powerplant Mechanic, Chase Plane Pilot UAS Pilot, UAS Test Pilot, UAS Instructor, Sensor Operator, Observer, 1200+ UAS hours, Gnat 750, IGnat, Pioneer, Sentry STM-5A/B, Exdrone, Pointer, Manta, Silver Fox, Cobra

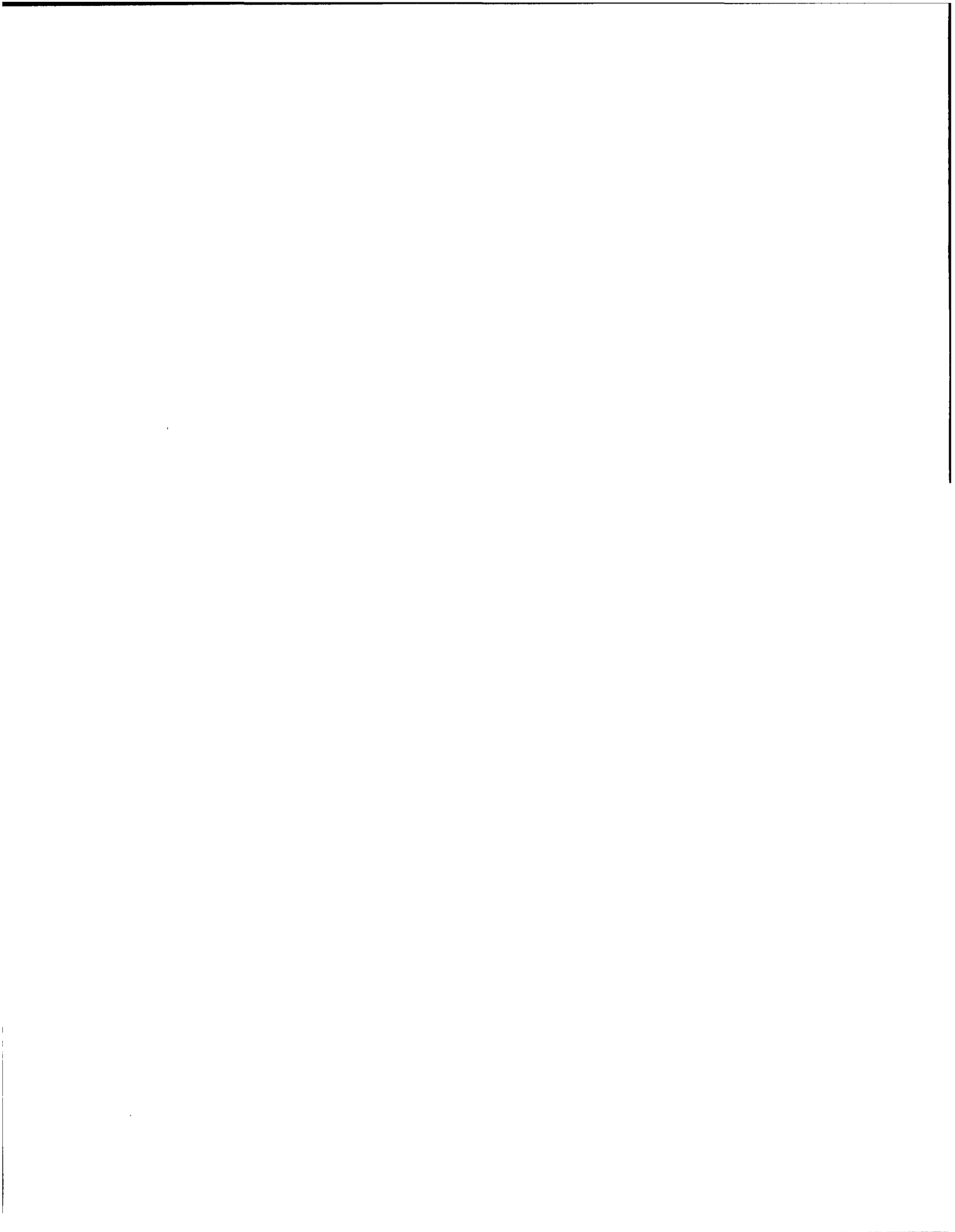

# Raytheon

## Supplemental Pilot

RC Pilot, RC Test Pilot, UAS Pilot, UAS Test Pilot, UAS Instructor, Observer, 230+ UAS hours, Manta, Silver Fox, Micro Fox, MAV, SUAV, LUAV, Cobra

- Pilots must be qualified and/or certificated in the appropriate category of aircraft, i.e., rotorcraft, powered lift, airplane, etc.
- Describe internal training program to qualify pilots.

Pilots are chosen for their experience with UAS, manned or RC aviation. Manned aircraft pilots are trained to be UAS Pilots, and RC pilots are trained to be Supplemental Pilots (SP).

All pilots are given detailed information on the UAS system, including aircraft performance, limitations, flight controls, communications, autopilot functions, datalink operation, local procedures, crew coordination and emergency procedures.

In addition, specific training will be given in the following areas as it pertains to UAS operations:

- Applicable Federal Aviation Regulations
- NTSB Accident reporting requirements
- Aeronautical Information Manual and FAA advisory circulars
- Aeronautical charts for navigation
- Radio communication procedures
- Weather, windshear avoidance, and aeronautical weather reports and forecasts
- Aircraft collision avoidance, and wake turbulence;
- Density altitude effects
- Weight and balance computations
- Principles of aerodynamics, powerplants, and aircraft systems
- Stall awareness, spin entry, spins, and spin recovery techniques
- Aeronautical decision making and judgment
- Preflight action that includes how to obtain information on runway lengths at airports of intended use, data on takeoff and landing distances, weather reports and forecasts, and fuel requirements.
- Preflight preparation, preflight procedures, airport operations, takeoffs, landings, and go-arounds, navigation, slow flight and stalls, emergency operations, and postflight procedures.

The Pilot is given additional training on the software operator interface, and mission commander duties and is required to be familiar with SP pilot duties. A simulator is used prior to Pilot flight training. Pilots will demonstrate this knowledge to the correlation level prior to Raytheon certification.

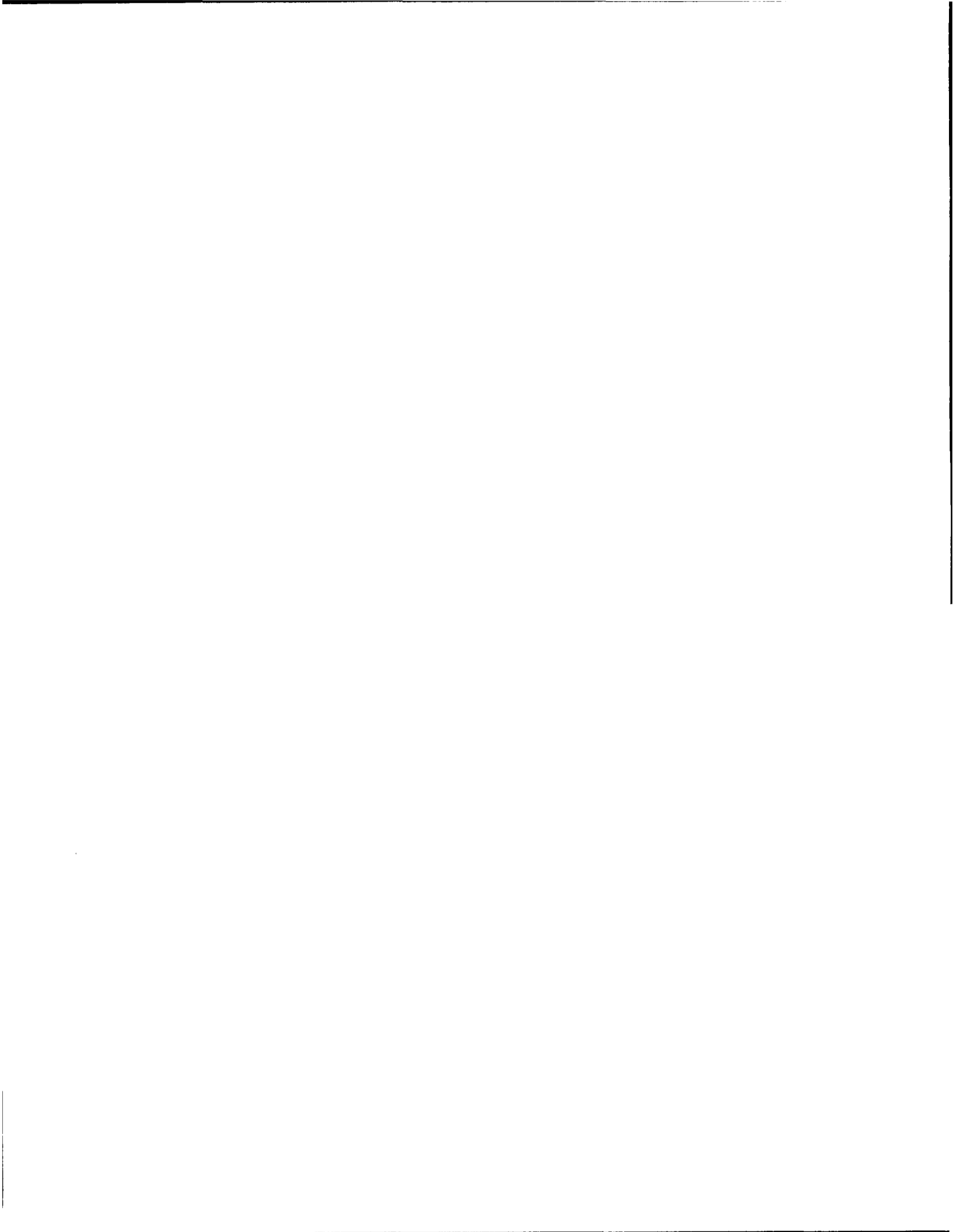

# Raytheon

The SP is also trained to take manual control as required to avoid other aircraft and is required to be familiar with pilot duties.

- Describe the qualifications and training of observers.

Observers are trained in scanning techniques, and to verbally communicate the location of other aircraft. Observers will have instruction on 14 CFR § 91.111 and 91.113.

## 7. Aircraft Marking (14 CFR § 45)

- All Cobra UAS are required to be registered and identified with the registration number. (45.29(f))
- Unless otherwise specified in the certificate, the aircraft will be marked on the aft fuselage surface using the N12345 format. 3" lettering will be used due to the small size of the aircraft. The word "Experimental" will be displayed on the fuselage over the wing in ½" letters.

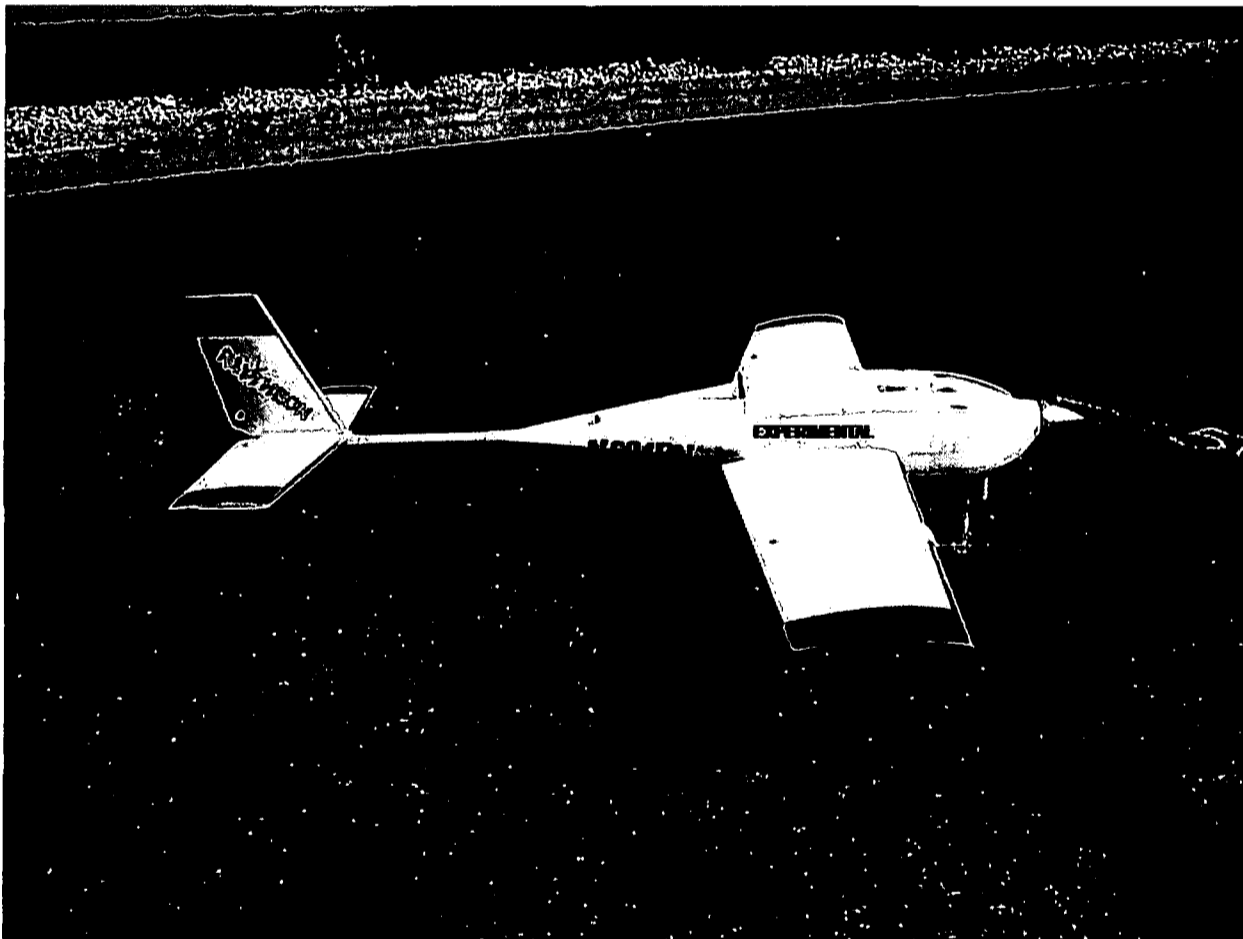

## 8. ATC Transponder and Altitude Reporting System Equipment and Use (14 CFR § 91.215)

- Describe the aircraft altitude reporting system.

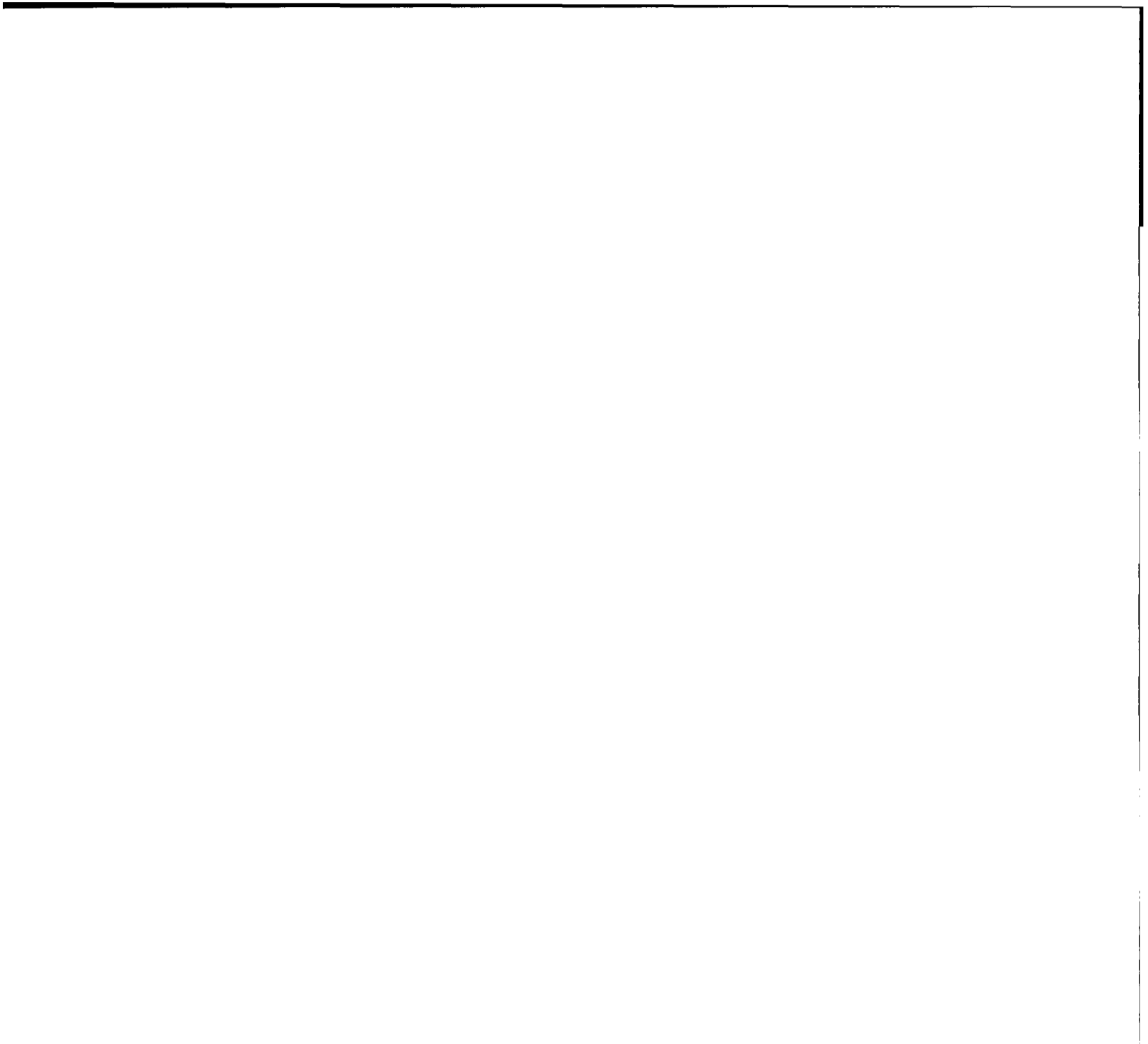



# Raytheon

The aircraft has a miniature air data system built into the autopilot. Altitude calibration is done daily via the GCS operator interface by setting the field elevation and local barometric pressure. The local barometric pressure is received from the ATIS broadcast from Libby Army Airfield.

An onboard Transponder with altitude encoder is installed. See Appendix E MEL. An independent Altitude Encoder will provide the pressure altitude for mode C. During integration testing, the mode 3 code will be manually set to 1200 or as assigned before launch. When the software interface has been developed, the transponder will be accessible to the pilot for mode 3 code changes, ident, and Off/Standby/On/Alt functions.

## 9. Method for See and Avoid (14 CFR § 91.113a)

- In what manner, or by what means, will the requirement to “see and avoid” other aircraft be met?

For local flights a ground observer will be used to see other aircraft.

Raytheon will have a chase plane for all flights outside visual line of sight. The chase plane will be manned by a pilot and observer. Raytheon will comply with the FAA definition of observer. The roll of the observer will be to look for and call out all other air traffic. The observer will not have FTS capability. Voice communications between the chase aircraft and the UAS pilot at the Ground Control Station will be by VHF radio. In the event voice communication is broken with the chase aircraft for more than 1 minute, the UAS will be returned for landing. At any time during the flight, the UAS pilot will be able to take control and maneuver as required to avoid other aircraft as directed by the chase plane observer. In an emergency the UAS pilot can execute the terminate flight function built into the autopilot. The chase aircraft will be squawking 1200 or as assigned. The pilots of the chase aircraft and UAS will have a face to face formation brief prior to all chase flights.

- What performance will the chase plane have?

The chase aircraft will have the performance required to keep the UAS in sight at all expected airspeeds and altitudes.

## 10. Safety Risk Management

- An applicant must provide a hazard analysis that identifies and analyzes the hazards of UAS operations that are described in the program letter.

See Appendix G

- Additional information is available by contacting the FAA representative.

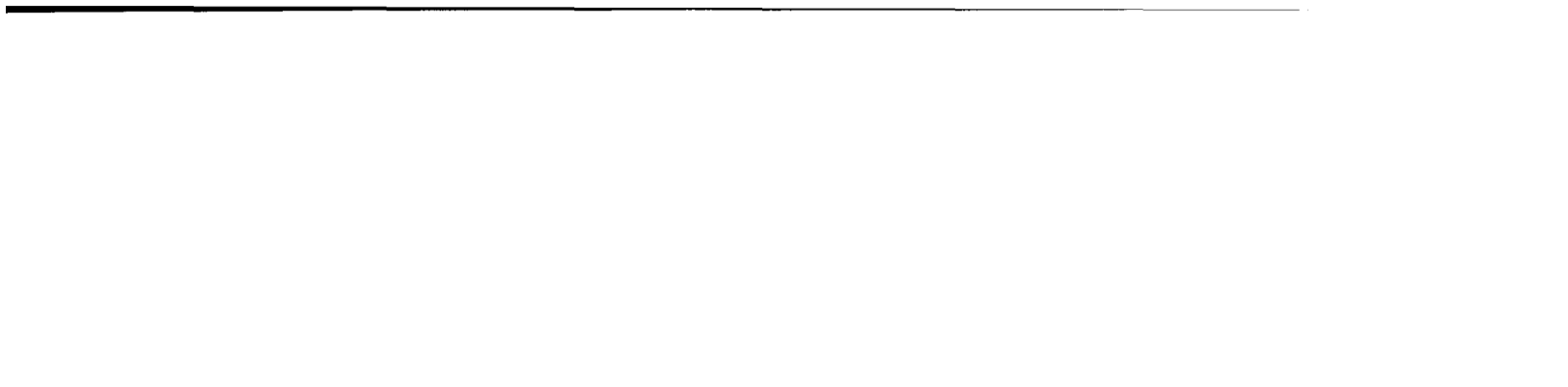

## 11. System Configuration

- Provide description of aircraft system configuration and all on-board and ground-based equipment.

Provided in paragraph 4, Aircraft Configuration. See Appendix F for a system diagram.

## 12. System Safety – Flight Termination and Lost Link

- What is the expectation of aircraft “Flight” if fuel is starved?

The system will provide the pilot with a visual and aural warning that the engine has failed. The aircraft will glide at the current commanded airspeed and continue to navigate to the next waypoint on the active flight plan. The backup battery system will continue to power the aircraft and all electrical systems in excess of one hour at maximum load. If altitude permits, the pilot will navigate the aircraft to a landing point of his choosing, and if video is available, he will use video to avoid obstructions on the ground.

- Describe/explain aircraft lost link and emergency recovery procedures.

- Command and Control

The Piccolo autopilot is programmed to fly to a “lost link” waypoint that is a point on a lost link flight plan. The lost link point can be changed during the course of the flight to follow the operational flight plan. The Pilot plans the lost link route to return to base at a safe altitude, and on a predictable flight path. The final 4 points on the lost link plan are looped to create a loiter pattern. If desired, the pilot can plan the lost link route to land the aircraft autonomously. The lost link timeout is set by the pilot during preflight. Raytheon procedure is to set the timeout to 10 seconds. During launch and recovery, the lost link point is set to a point on the departure end of the runway to prevent a turn close to the ground and in proximity to the GCS in case of lost link during the takeoff roll or during final approach.

A backup Piccolo GCS/datalink is available, and will be used in the event of GCS failure.

- Flight Termination

- In the event that datalink is lost and/or GPS becomes unusable, the Piccolo II autopilot can be set to automatically activate the flight termination function. The function will kill the engine, forcing a landing, or, if desired, can cause an aerodynamic termination. The details can be found in Appendix B, Piccolo II Users Guide. Raytheon sets this option to kill the engine if GPS fails. Figure 8 shows the settings available to the pilot for automatic flight termination. In Piccolo terminology, the “Deadman Line” is the ignition system.

Manual termination is done by killing the engine or selecting manual control and overriding the autopilot.

---

1  
2  
3  
4  
5  
6  
7  
8  
9  
10  
11  
12  
13  
14  
15  
16  
17  
18  
19  
20  
21  
22  
23  
24  
25  
26  
27  
28  
29  
30  
31  
32  
33  
34  
35  
36  
37  
38  
39  
40  
41  
42  
43  
44  
45  
46  
47  
48  
49  
50  
51  
52  
53  
54  
55  
56  
57  
58  
59  
60  
61  
62  
63  
64  
65  
66  
67  
68  
69  
70  
71  
72  
73  
74  
75  
76  
77  
78  
79  
80  
81  
82  
83  
84  
85  
86  
87  
88  
89  
90  
91  
92  
93  
94  
95  
96  
97  
98  
99  
100

---

When the developmental datalink is installed, the Piccolo Microhard datalink can be used to sever the developmental link from the autopilot.

The screenshot shows a dialog box titled "Mission Limits - Piccolo '1'". It contains several sections for configuring flight parameters and termination conditions:

- Altitude Limits:** Min Altitude: 4698.2 [ft], Max Altitude: 6194.2 [ft]
- Flight Timer:** Flight Timeout: 3600 [s],  Land if timeout AND lost comm
- Timeouts:** GPS Timeout: 20.0 [s], Comm Timeout: 10.0 [s], Pilot Timeout: 2.0 [s]
- Waypoints:** Lost comm waypoint: 88, Autoland waypoint: 90
- Assert Flight Termination if:**
  - GPS times out
  - Comm times out
  - GPS AND Comm time out
- If Flight Termination is Asserted:**
  - Close Throttle
  - Drop Deadman Line
  - Aerodynamic Termination
  - Deploy Parachute
- If Engine Kill is Commanded:**
  - Drop Deadman Line

Buttons at the top include "Open...", "Save...", "Request All", and "Send All".

Figure: 8 Piccolo Flight Termination Settings

- o Loss of GPS

In the event that the GPS signal is lost, the autopilot will navigate by Dead Reckoning (DR) with the magnetometer installed, or execute Flight Termination as selected by the pilot. Visual and aural warnings are given to the pilot if navigation accuracy cannot be maintained. The pilot has the option of visually navigating to landing.

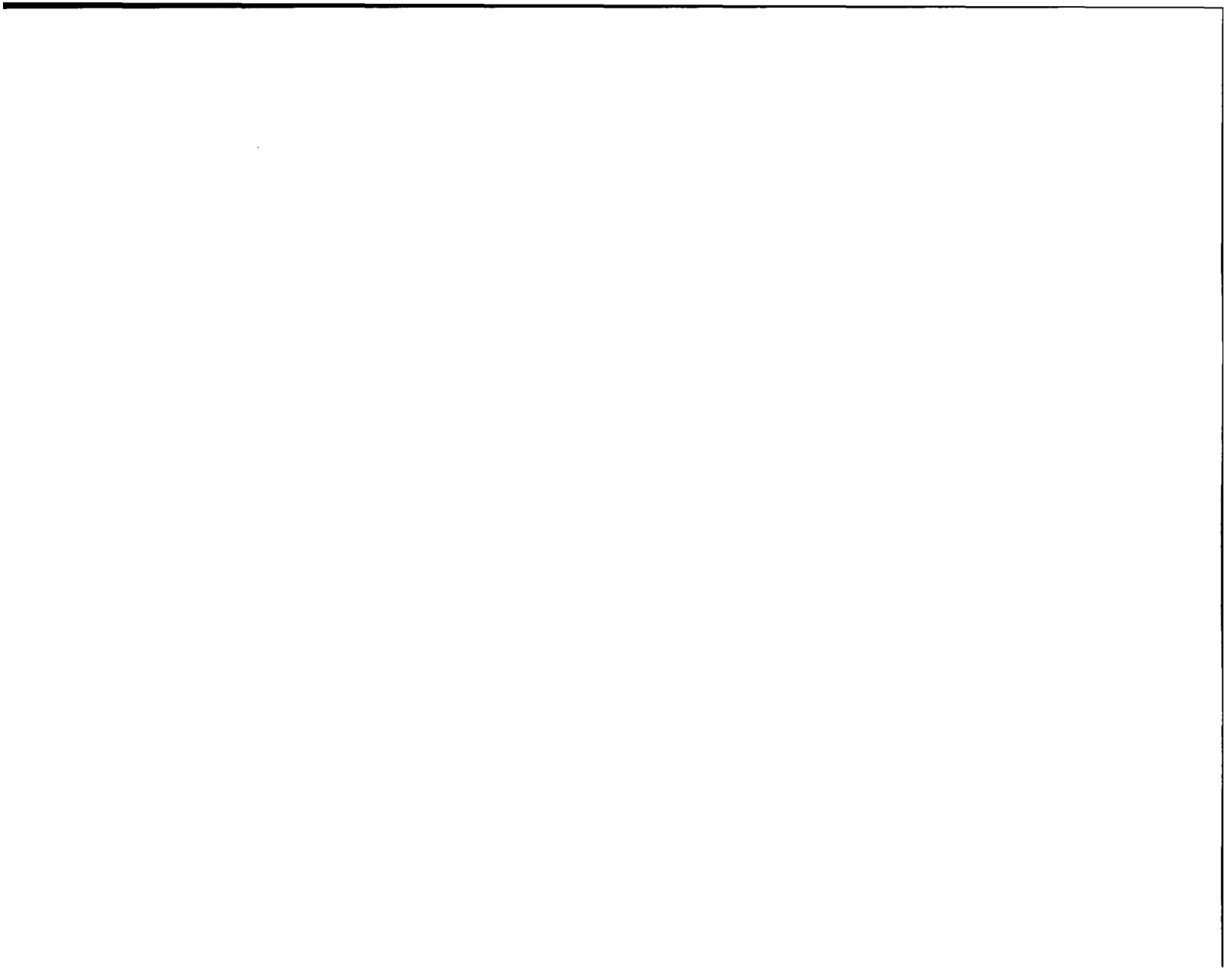

## 13. Command and Control

- Provide a description of the system and/or procedures for command and control of the UAS.

See Appendix C, Raytheon UAS Flight Manual

Cobra is manually taxied into takeoff position by the pilot or SP. The UA is launched by the pilot using Auto Takeoff. The pilot activates the takeoff by pressing the Launch button. The throttle is added slowly, and increases as forward speed is detected. The UA steers to centerline until rotation speed is reached at which time the autopilot raises the elevator for rotation. A climb rate is followed for a set time, and then switched to flight mode and the UA proceeds to the next waypoint in the takeoff flight plan.

The UAS can also be launched by the SP using manual control. Once the aircraft is airborne, the SP enters the pattern and verifies UA controllability. During the controllability check the SP trims the UA for hands off flight. The UA is then set to "Auto" mode, which sends the aircraft to a pre-planned flight route that duplicates the traffic pattern. This is done to observe the UA response to autonomous flight while still in visual range of the observer.

The route varies with the runway in use, but is overlaid on the landing pattern. The distance will be approximately 1/2 mile upwind or downwind at landing pattern altitude and 1/2 mile abeam. The Pilot is verifying health, status, and proper GPS tracking. The Supplemental pilot can take manual control with a switch on the manual controller if required. The Pilot can rapidly change the waypoint, altitude or airspeed, or can select a heading to fly.

The Pilot has several options with autonomous flight control. The flight plan controls the waypoint, turn type, slope, and altitude. The altitude hold can be overridden by the Pilot, while the aircraft continues to navigate to the selected waypoint. Airspeed hold is always set by the Pilot independent of the flight plan. During pre-flight, the Pilot sets minimum and maximum limits on the airspeed, altitude, pitch angle, and roll angle, which prevents the autopilot from exceeding safe limits. The airspeed and altitude hold command value cannot be set to exceed the limits.

If desired the Pilot can override the waypoint navigation and set the aircraft to maintain a turn rate, or heading. The Pilot can also select a waypoint for "Direct To" navigation. Any waypoint previously loaded can be selected. Also the pilot can select a "loiter now" function, where the aircraft orbits around its current position. Given the "point and click" map interface for setting waypoints, any waypoint can be quickly and easily moved by dragging it to a new position on the map.

Two stability augmentation modes are available to assist with the manual pilot console. Steering Mode overrides the waypoint navigation allowing the SP or Pilot to steer the aircraft with the manual control stick, while maintaining airspeed and altitude hold. The manual control stick commands a turn rate proportional to the amount of stick deflection. Full Authority mode overrides waypoint navigation, altitude, and airspeed hold using the manual pilot console. Steering is accomplished the same as in Steering Mode, Altitude is set by throttle command, and airspeed is set by pitch command. For airspeed, the stick

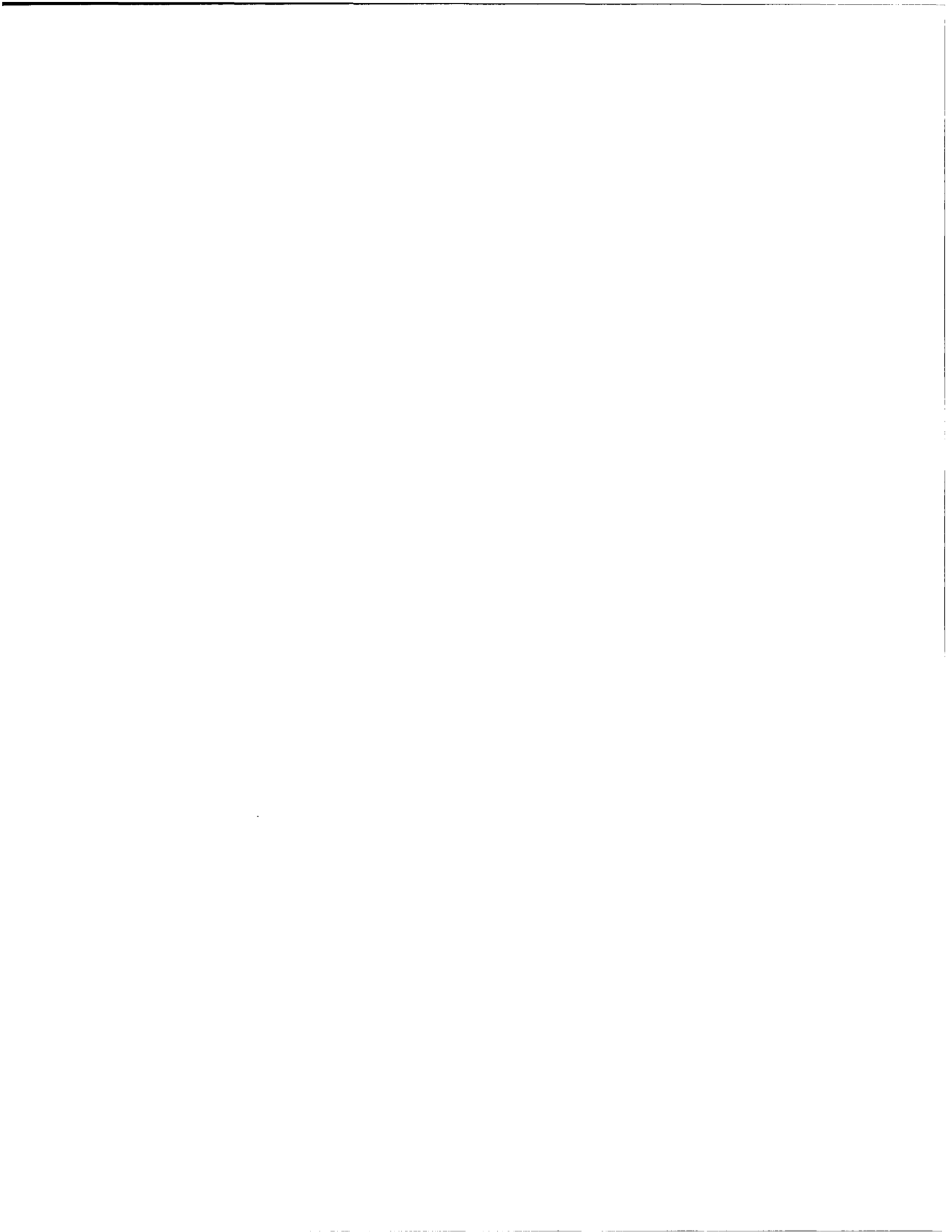



---

# Raytheon

neutral pitch position will keep the UA at the current commanded airspeed hold, while pitch down/up will increase/decrease the airspeed proportional to the amount of stick deflection.

When required, the SP or Pilot can disconnect the autopilot from the flight controls by selecting manual control on the manual pilot console. All telemetry is available during manual operation.

When the flight is complete, the Pilot sends the UA to the pre-planned landing route. This is the Autoland function. These waypoints are designed to fly a landing pattern of a pre-selected length and glideslope to a specific landing point. A flair altitude and speed is set, and there is an option to kill the engine at the flair altitude. The pilot can select "go-around" with the push of a button which forces the aircraft back to the first point of the landing plan, or he can select any other waypoint or flight mode as described above. This is the normal landing mode for Raytheon.

If the Pilot chooses, he can use the stability augmentation modes to fly the pattern using his telemetry, instrumentation, and video to land the UA.

The RC controller is hard wired to the datalink for the Supplemental pilot. At any time he can take manual control by a switch and land using the manual controller.

## 14. Control Stations

- Provide a description of the ground/airborne stations used to control the UAS.

The GCS is composed of 1-4 laptop computers, a ground datalink module, and a power supply. These can be used in any shelter, or in the open. The manual pilot console is connected directly to the ground datalink module, and remains functional in the event of computer failure. Raytheon uses a panel truck to house all the equipment and provide environmental protection. An intercom system is installed allowing for crew communications during flight. An aviation band VHF radio is connected so that all voice communications are heard by the flight and ground crews. All video and voice communications are recorded onto a digital recorder.

The minimum configuration for flight is a laptop with the Piccolo Operator Interface (OI) pilot console software, the Piccolo ground datalink module, and Piccolo manual pilot console. The Piccolo OI has a moving map display, and screens for commanding all modes of flight and for observing all status telemetry received from the UA. See Appendix B. The maps used by Raytheon for the Piccolo OI are exported from the Falcon View PFPS route planning software. Falcon View is updated with current ECHUM and DAFIF information on a 28 day cycle. All telemetry files are logged onto the computer, and are archived during postflight. Visual and audible alarms are used to warn the operator of RPM, Altitude, Airspeed, System, Datalink (Comms) and GPS errors. There are additional data points in the displayed telemetry, but these are the only ones with an alert.

Additional computers can be added and networked together for additional functionality. MVCS consisting of a CUCS and VSM can be connected giving the pilot a virtual MFD. The CUCS pilot console has a moving map display, a PFD, and other displays for



# Raytheon

commanding all flight modes and receiving all status telemetry and the moving map display will show the location of every UA on the network. The VSM can be hosted on the GCS computer or in the ECM aboard the UA.

Both the Piccolo OI and the MVCS can manage up to 4 aircraft simultaneously, or a pilot console can be added to the network for each UA.

## 15. Control Frequencies

- Provide a description/listing of the frequencies used to control the UAS.
  - o Microlight (Raytheon) Datalink
  - o Primary: 420-450 MHz
  - o Microhard (Piccolo) Datalink
  - o Secondary: 902-928 MHz
- Video Datalink
  - o Blackwidow 2.4 GHz
  - o <http://www.blackwidowav.com/bwav240200urban.html>
  - o GMS 2.4 GHz
  - o [http://www.gmsinc.com/product\\_details.asp?prod\\_idno=105](http://www.gmsinc.com/product_details.asp?prod_idno=105)
- Frequency Manager Points of Contact:
  - o FAA Western Pacific Region  
Frequency Management Officer  
AWP-471  
Sidney Bradfield  
Federal Aviation Administration, Western-Pacific Region  
15000 Aviation Boulevard  
Hawthorne, CA 90250  
310-725-3671  
[sydney.bradfield@faa.gov](mailto:sydney.bradfield@faa.gov)

o

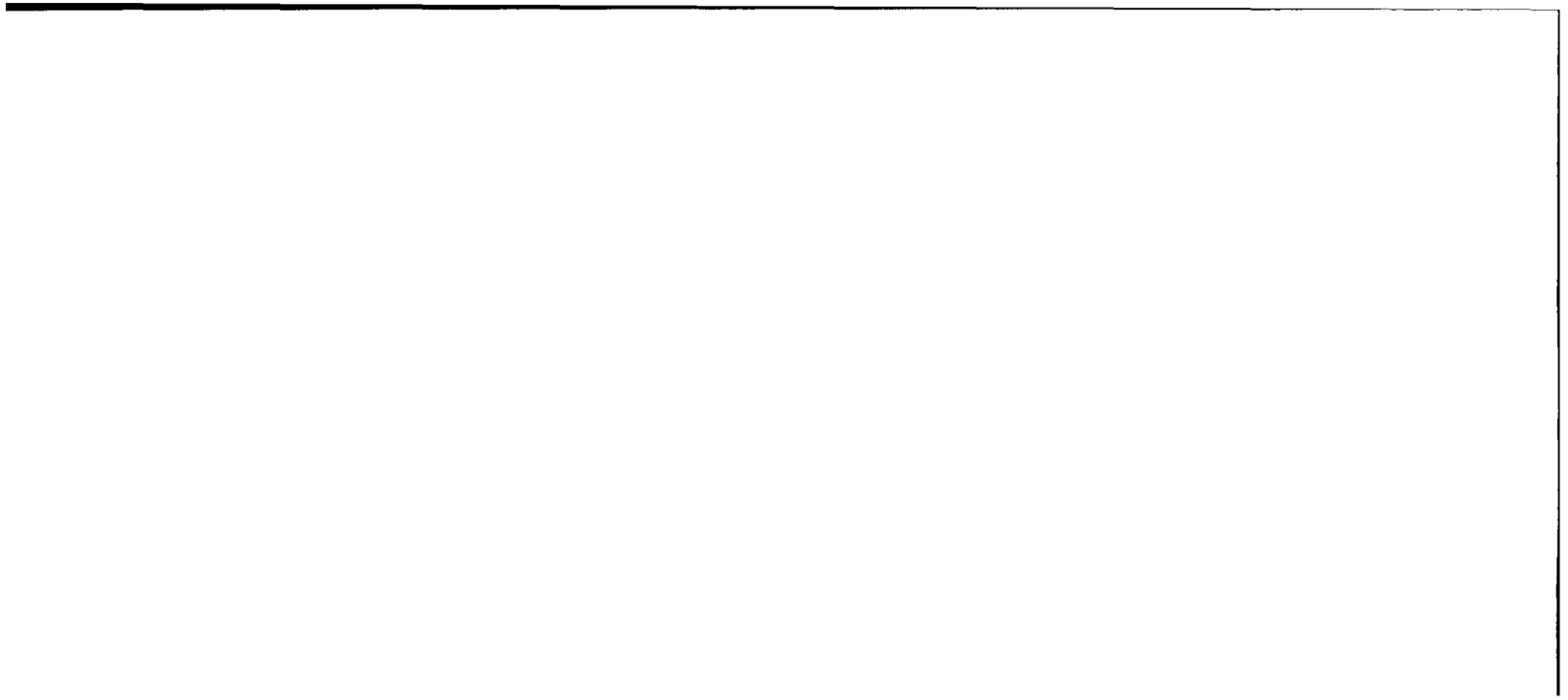

---

# Raytheon

- DoD Area Frequency Coordinator State of Arizona  
Rod Hanson  
Arizona Ave Bldg 85846  
Ft. Huachuca, Arizona 85613-5000  
520-538-6423  
[rodney.hanson@us.army.mil](mailto:rodney.hanson@us.army.mil)
- Raytheon Frequency Coordinator  
Thomas J. Fagan  
Raytheon Missile Systems  
E3 & Spectrum Management  
P.O. Box 11337  
Bldg M02 M/S T16  
Tucson Arizona 85734-1337  
520-794-0227  
[tjfagan@raytheon.com](mailto:tjfagan@raytheon.com)

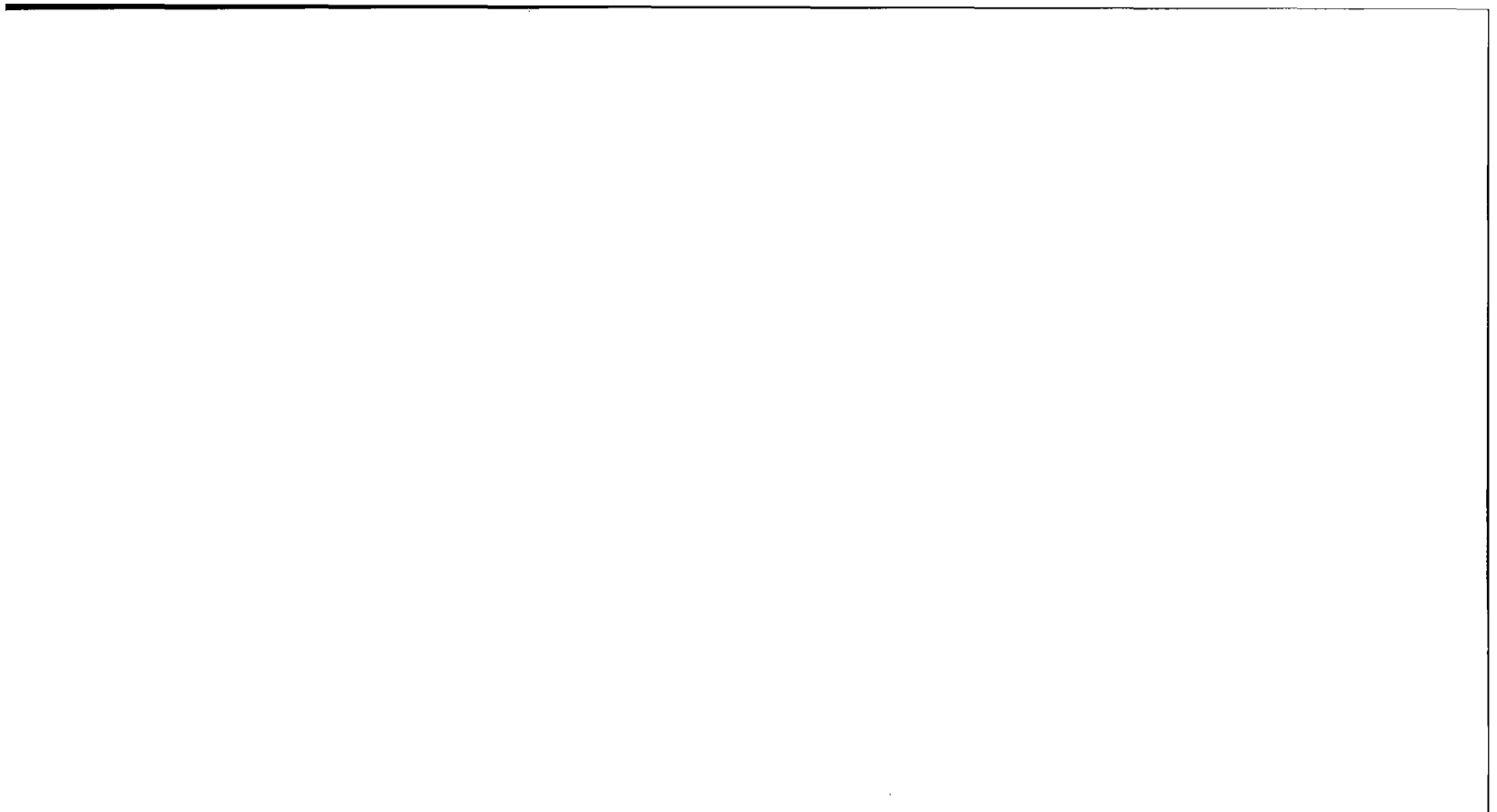

## Appendix A - Cobra Drawings and Photographs

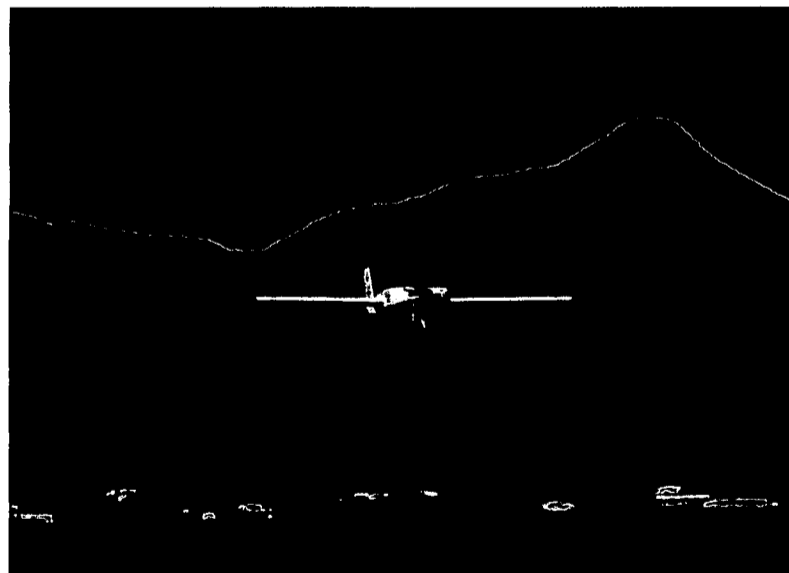
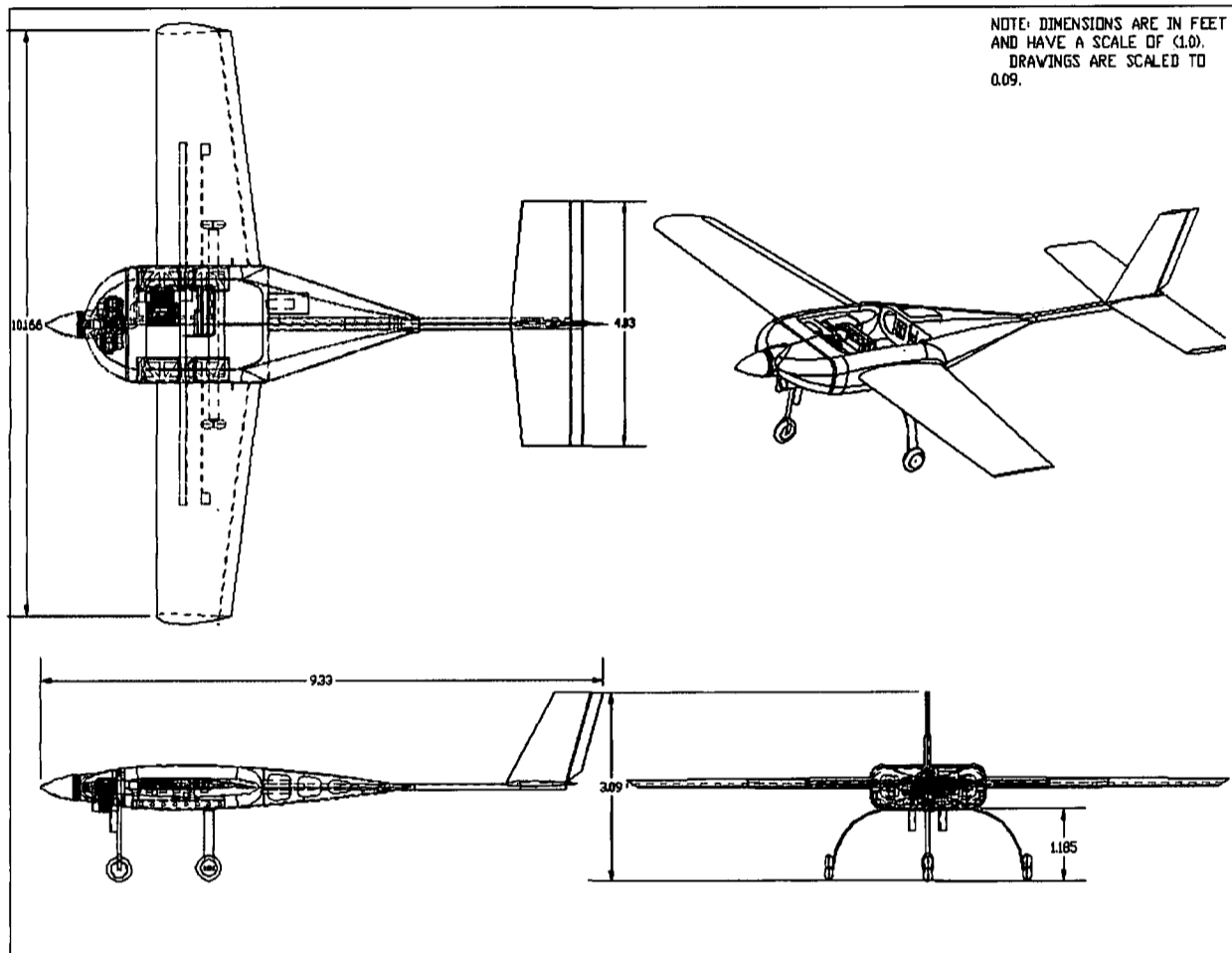

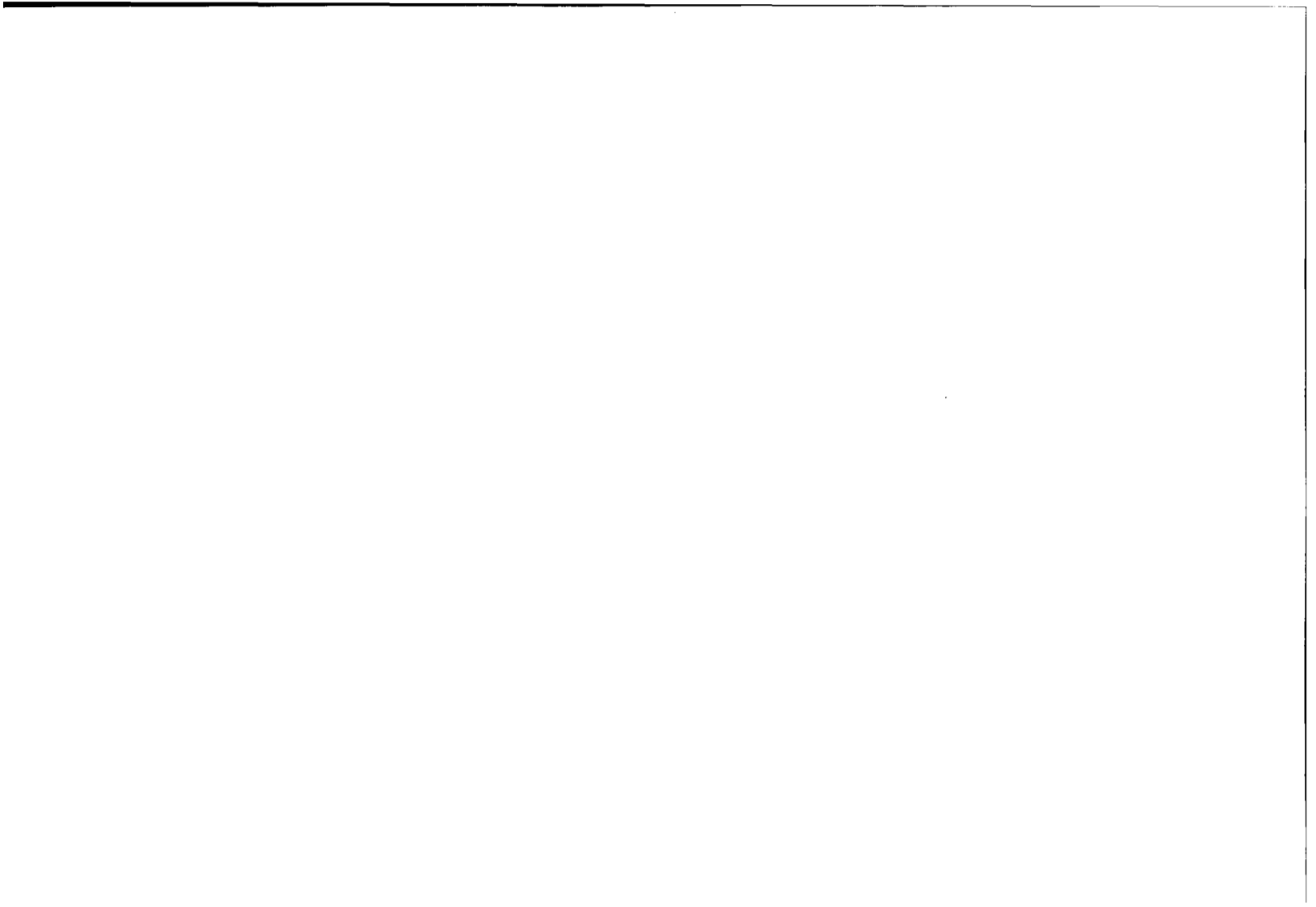



# Raytheon

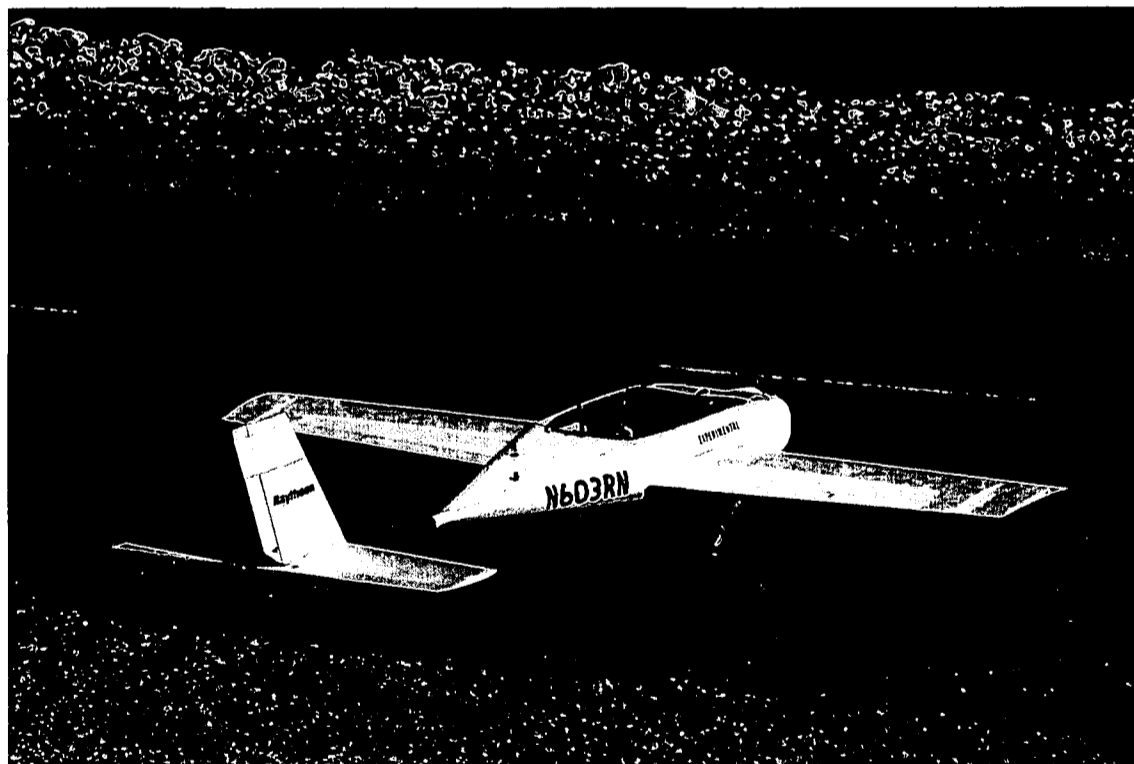



# Raytheon



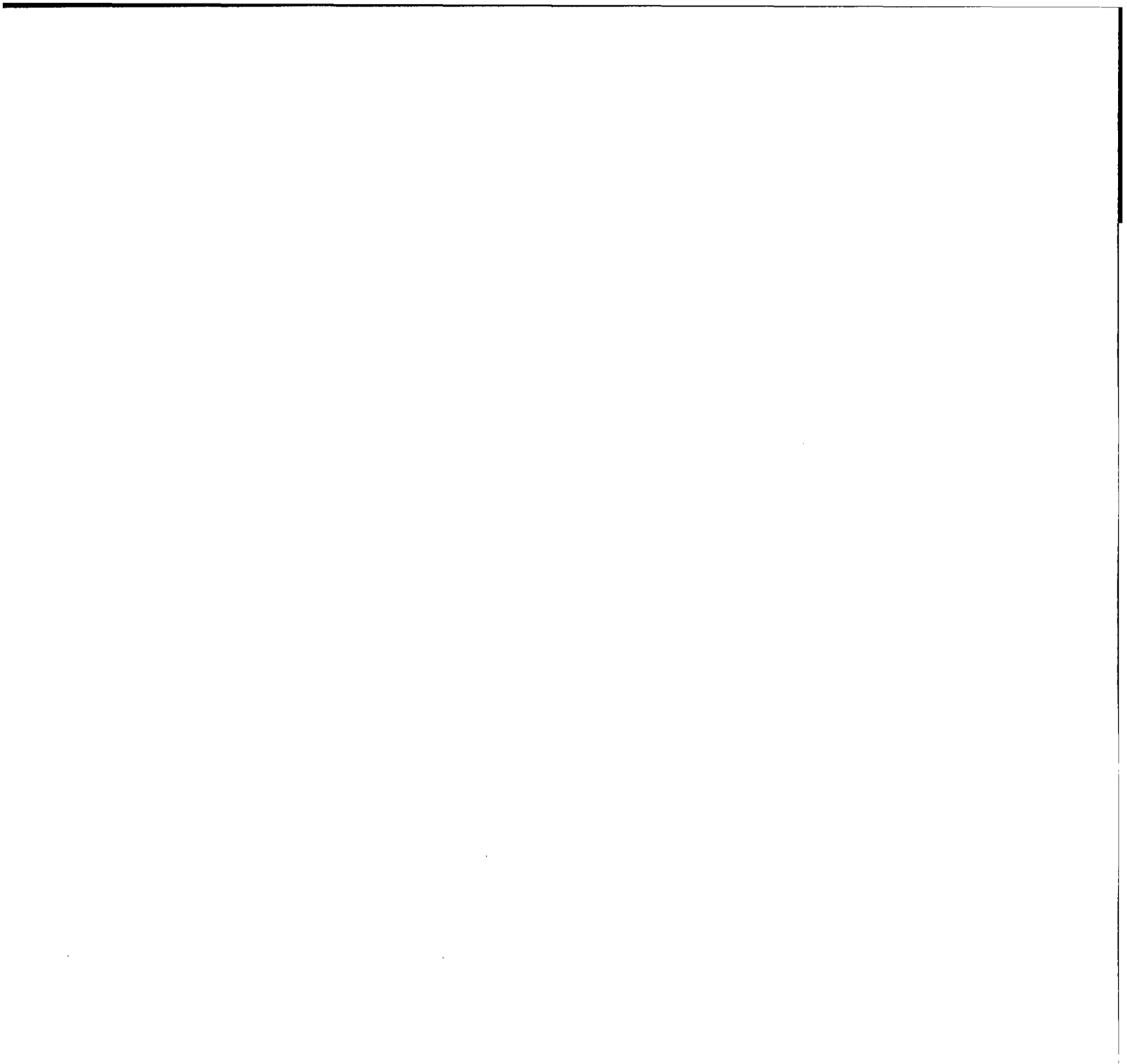

**Raytheon**

*Appendix B - Cloud Cap Piccolo II Users Guide*

Separate Document

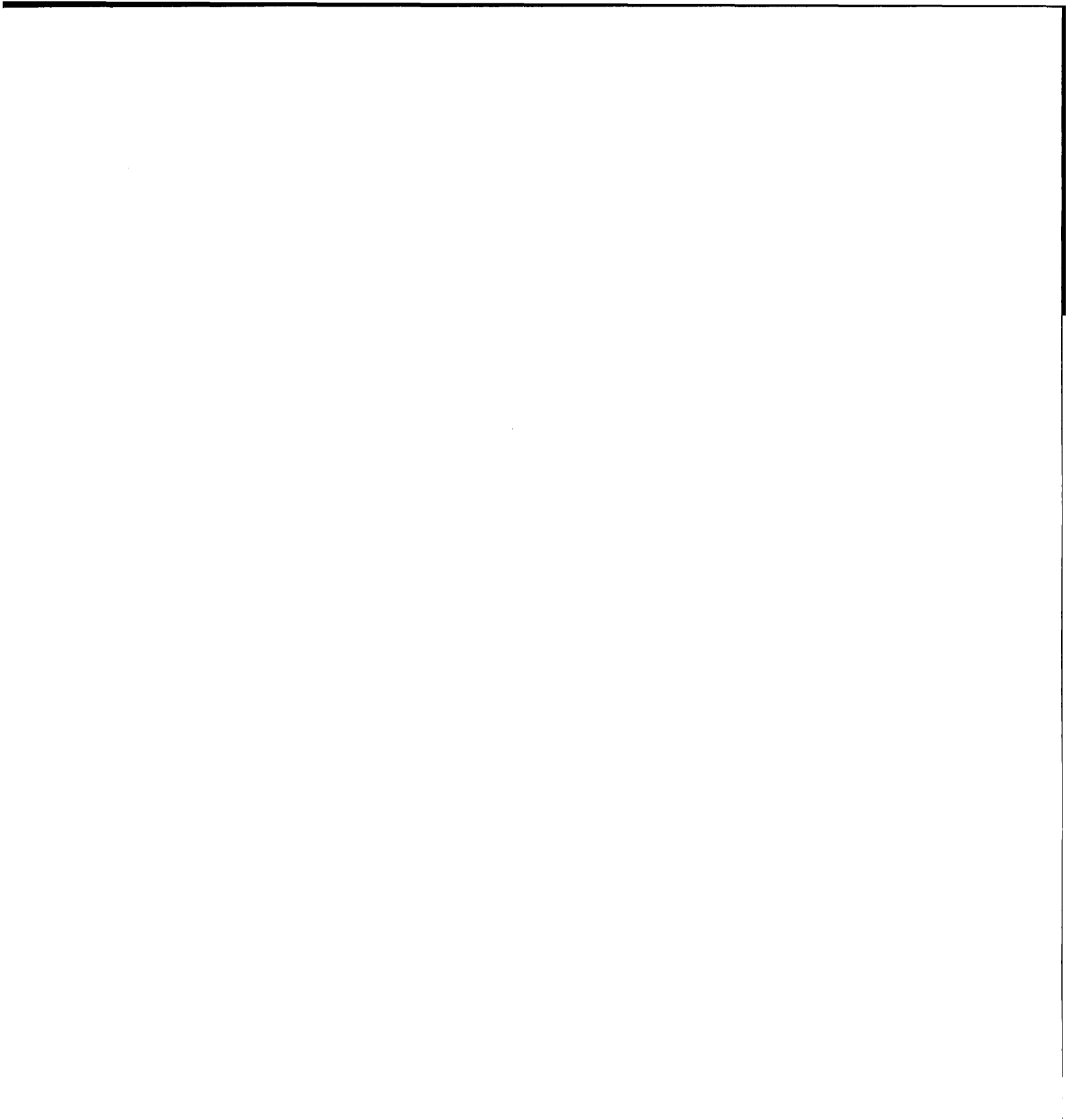

## Appendix C - Raytheon UAS Flight Manual

Separate Document

### Appendix D - Cobra Weight and Balance

This is a preflight planning tool. It is not real-time, in that the "system" does not constantly compute the CG based on fuel burn. The Wt and Bal is conducted before each flight based on the weight and arm of the variable items. Given the test nature of our operations, Raytheon will conduct a full weighing of the aircraft before a flight if required.

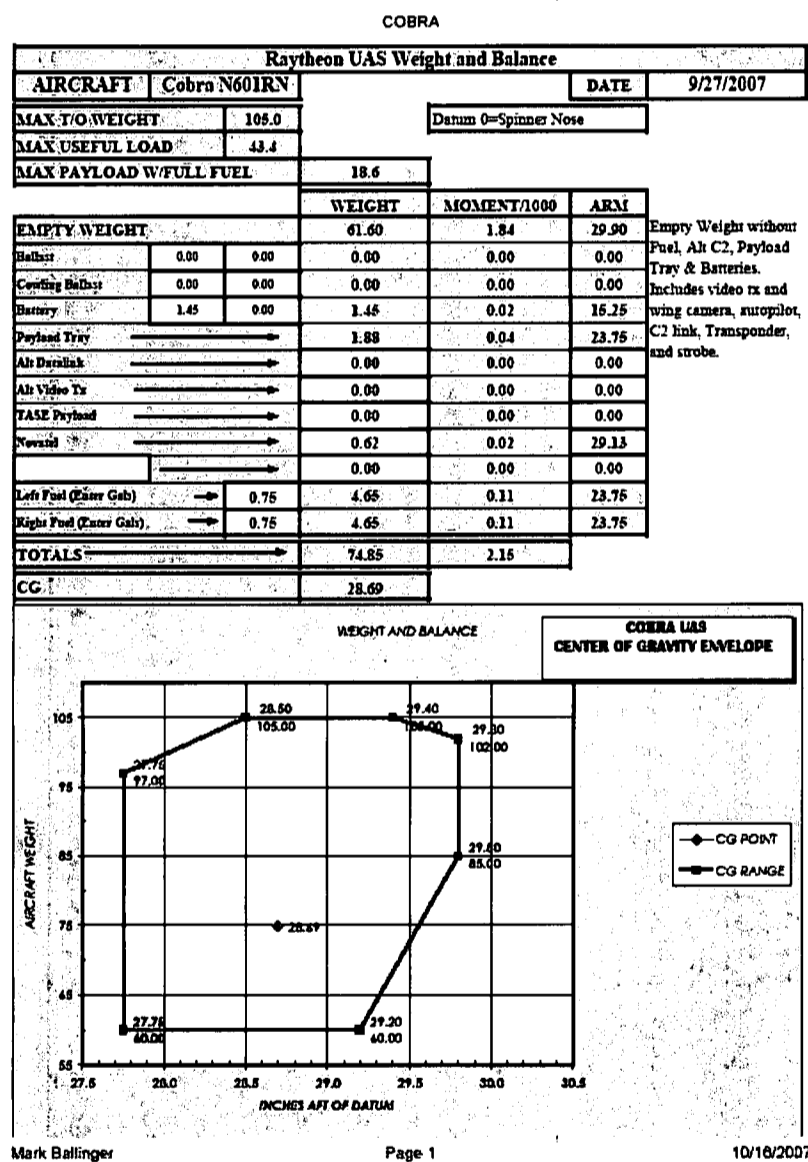

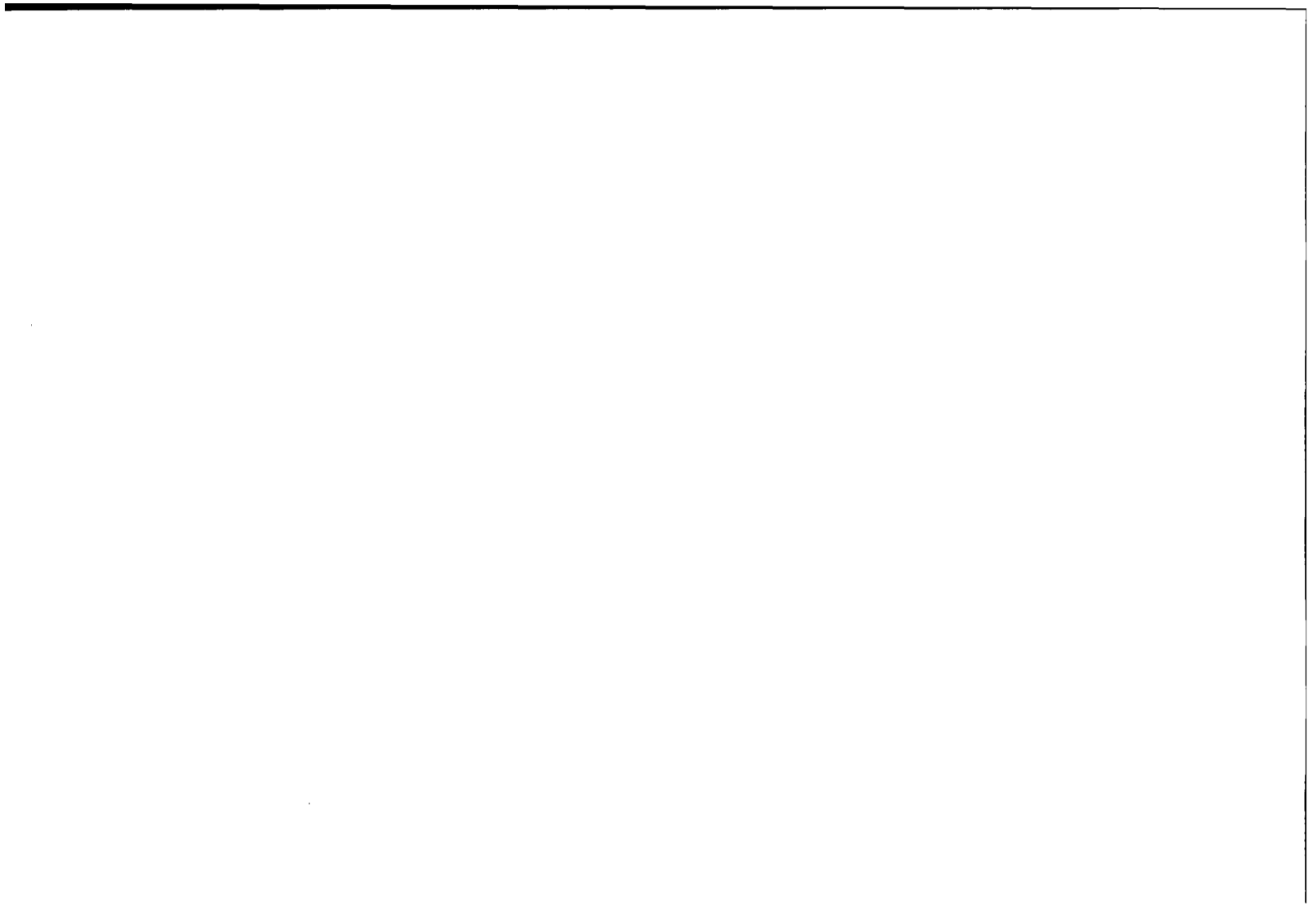



## Appendix E - Minimum Equipment List

The Minimum Equipment List (MEL) for this UAS will be used to show optional equipment configurations. Since all flight operations will be done in day VFR conditions, there will not be an option for night operations. However, the difference between a local flight and a range flight beyond 1 NM from the launch site will be delineated.

R – Required N – Not Required

Sub-System	Local Flight	Range Flight
Piccolo II Autopilot	R	R
Brakes	R	R
Generator	R	R
Regulator	R	R
Strobe Light	R	R
Transponder	R	R
Altitude Encoder	R	R
Magnetometer	R	R
Piccolo GCS	R	R
Manual Pilot Controller	R	R
MVCS	N	N
MicroHard Datalink and Antenna	R	R
MicroLight Datalink and Antenna	N	N
NetFires Datalink and Antenna	N	N
Video Transmitter and Antenna	N	N
Video Camera – Fixed	N	N
Video Camera – Gyro-Stabilized	N	N
Embedded Computer Module	N	N
DA-150 16 Hp Engine (W/Ign Module)	R	R
150 Muffler Set (W/Bolts, Gaskets, Plug Screws)	R	R
Mejlik 30x12 Propeller	R	R
IGN Sensor	R	R
RPM Sensor	R	R

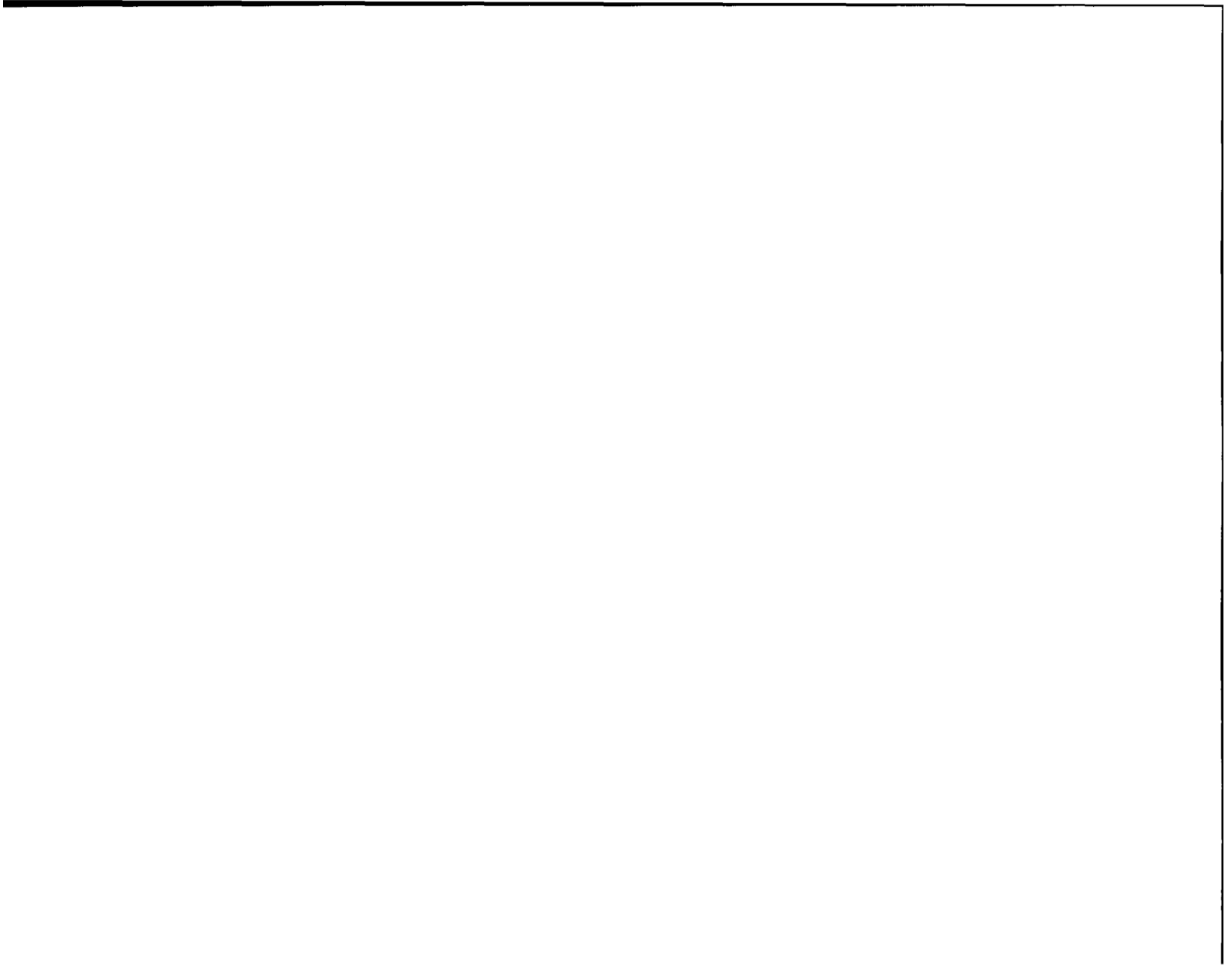

## Raytheon

Hitec Hsc-5955 Titanium Gear High Speed Servo S	R	R
Robart 168 Fill Valve/Fill Chuck	R	R
Dubro In-Line Fuel Filter	R	R
Robart 192 Large Pressure Tank	R	R
Dubro Dura-Collars 3/16" (4)	R	R
Robart 173 On Board Pressure Gauge	R	R
SLA 1.6 Gallon Tank	R	R
Dubro Fuel Tank 1500cc 50 Oz.	N	N
Fourmost Fitting Tee Large (4)	R	R
Sullivan Aluminum Nipple Fitting	R	R
Dubro Tygon Gas Tubing	R	R
Dubro Heavy Duty Ball Links 4-40 (12)	R	R
Dubro Threaded Rod 4-40 12" (24)	R	R
Sullivan UAV Generator W/Regulator	R	R
Trailing link shock strut nose gear	R	R
Brake Hub Set For The 5" To 6" Tuff Tread Aluminum Wheels	R	R
8 Spoke Brake Hub 6"	R	R
Heavy Duty Switch Harness With Charge Jack	R	R
GPS Cable Long SMA - Push On	R	R
GPS Cable Short SMA – SMA	R	R
Engine Mount Standoffs	R	R
Dzus Fasteners For Payload Hatch	R	R
Landing Gear Main Strut	R	R
I Hooks Hold Down Bolts	R	R
Nylon Tail Boom Attach Bolt	R	R
Engine Mount Bolts	R	R
Main Gear Attachment Hardware	R	R
Large Washer For Nose Wheel Strut	R	R
Dust Cover Cap For Air Fill Port	R	R
Brackets For Anti -Rotation	R	R

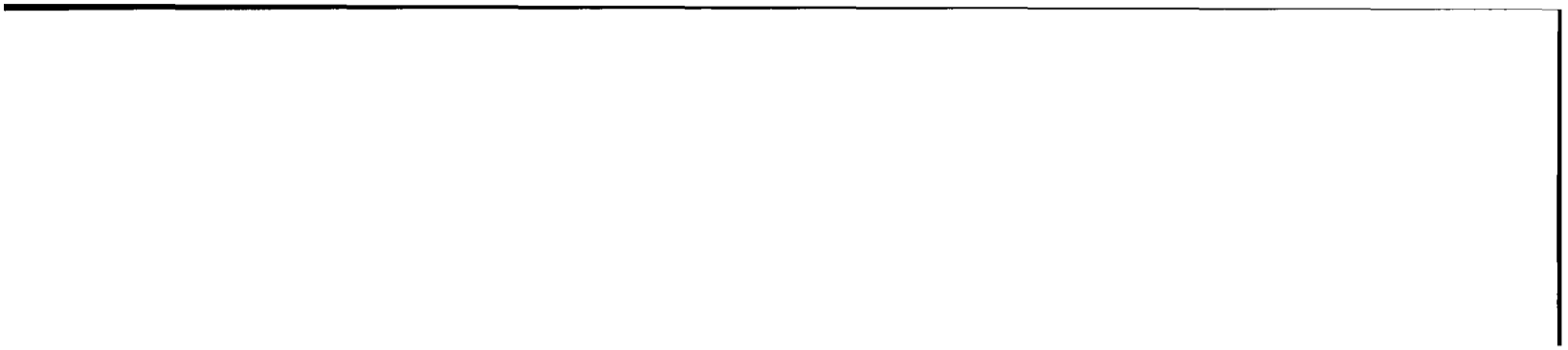

## Raytheon

Nose Wheel Strut Mounts	R	R
Nose Wheel Steering Control Arm	R	R
GPS Antenna	R	R
GPS Filter	R	R
Pitot/Static Tube	R	R
Prop Bolts	R	R
Spinner Bolt	R	R
Panel Mount Mini-Din Connector For Brake Controller Unit (5-Pin Elliott)	R	R
Male 5 Pin Din	R	R
Female 5 Pin Din	R	R
4-40 Metal Clevis	R	R
Deans Connectors	R	R
Control Horns Wing, Elevator, Rudder	R	R
Inline Futaba Connectors And Ext Cables	R	R
Inline Air Fitting For Pitot Tube Hoses	R	R
RED & BLACK Anderson Type Connectors (Ign Pwr, Eng Kill)	R	R
Servo Mount Blocks For Throttle Servo And Steering Servo	R	R
Mounting Provisions For Servos Installed In Tail Surfaces	R	R
NACA Air Scoop	R	R
Aft Fuselage Exhaust Vent Assembly	R	R
Power Control Module	R	R
SLS Pitot Tube Housing	R	R
Payload Tray For Ballast CG Testing	N	N
Spacer In Nose Wheel Strut To Compress Spring	R	R
Rubber Shock Mounts For Gen Voltage Regulator	R	R
Piccolo Connector (44 Pin)	R	R
SMA Feed Thru For Piccolo UHF Antenna	R	R
Piccolo UHF Antenna Coax SMA-SMA	R	R
10 K Ohm Resistor For Rpm Sensor	R	R

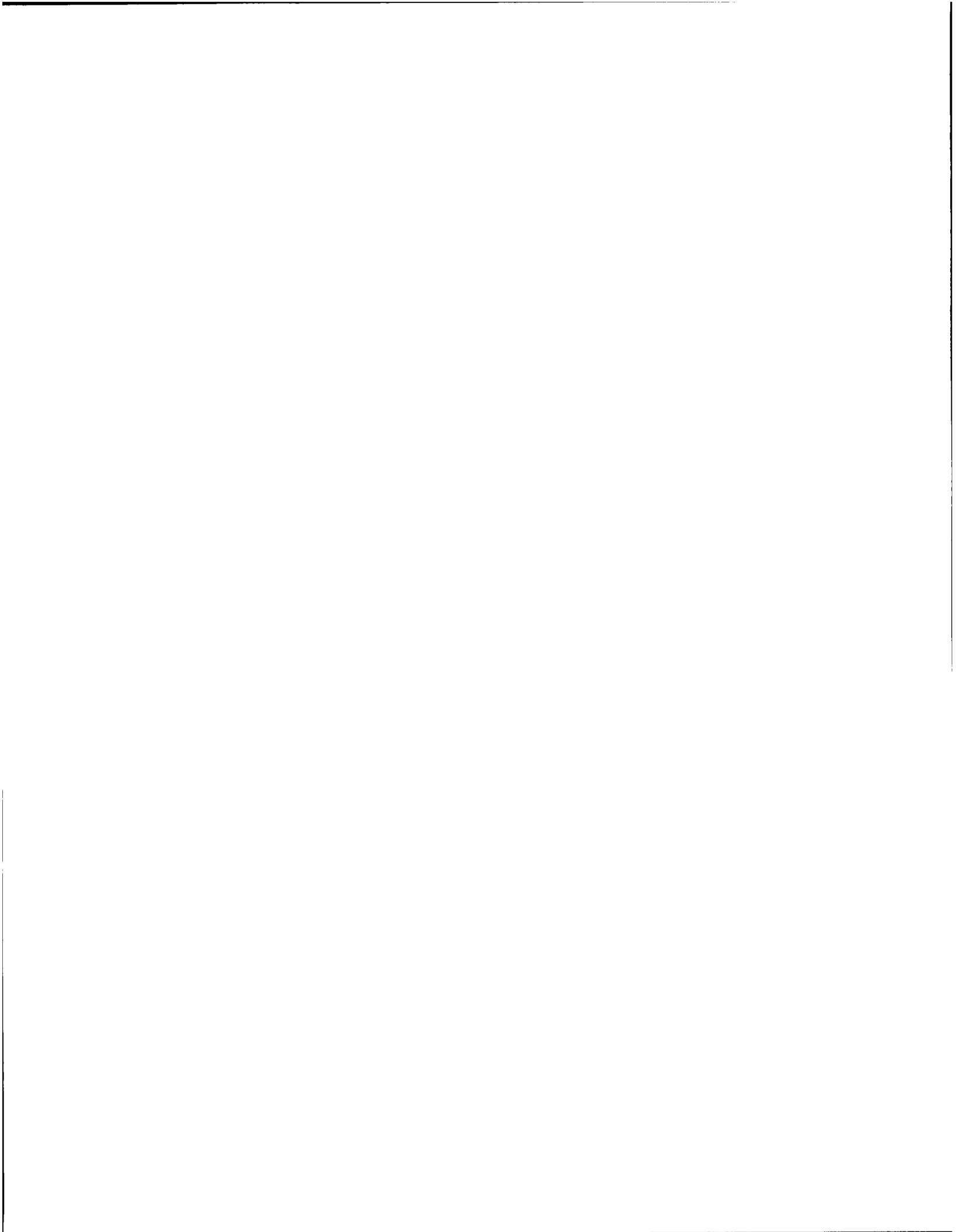

## Raytheon

Hose Clamps For Pitot Tubes	R	R
Connector For Piccolo II Payload Port	R	R
Metal Threaded Inserts In Wings To Secure Pitot Tube Housing	R	R
Bud Box For Brake Controller Unit 3.5 X 1 5/8 X 2"	R	R
Tail Skags (Great Planes, Aka Wingtip Skids)	R	R
Tail Boom Carbon Wrapped Tube 6' 1.0" ID,0.06" WT,56 G./Ft.	R	R
Wing Spar 1.25" ID, Cello-Wrapped.	R	R
Ballast Weights	N	N

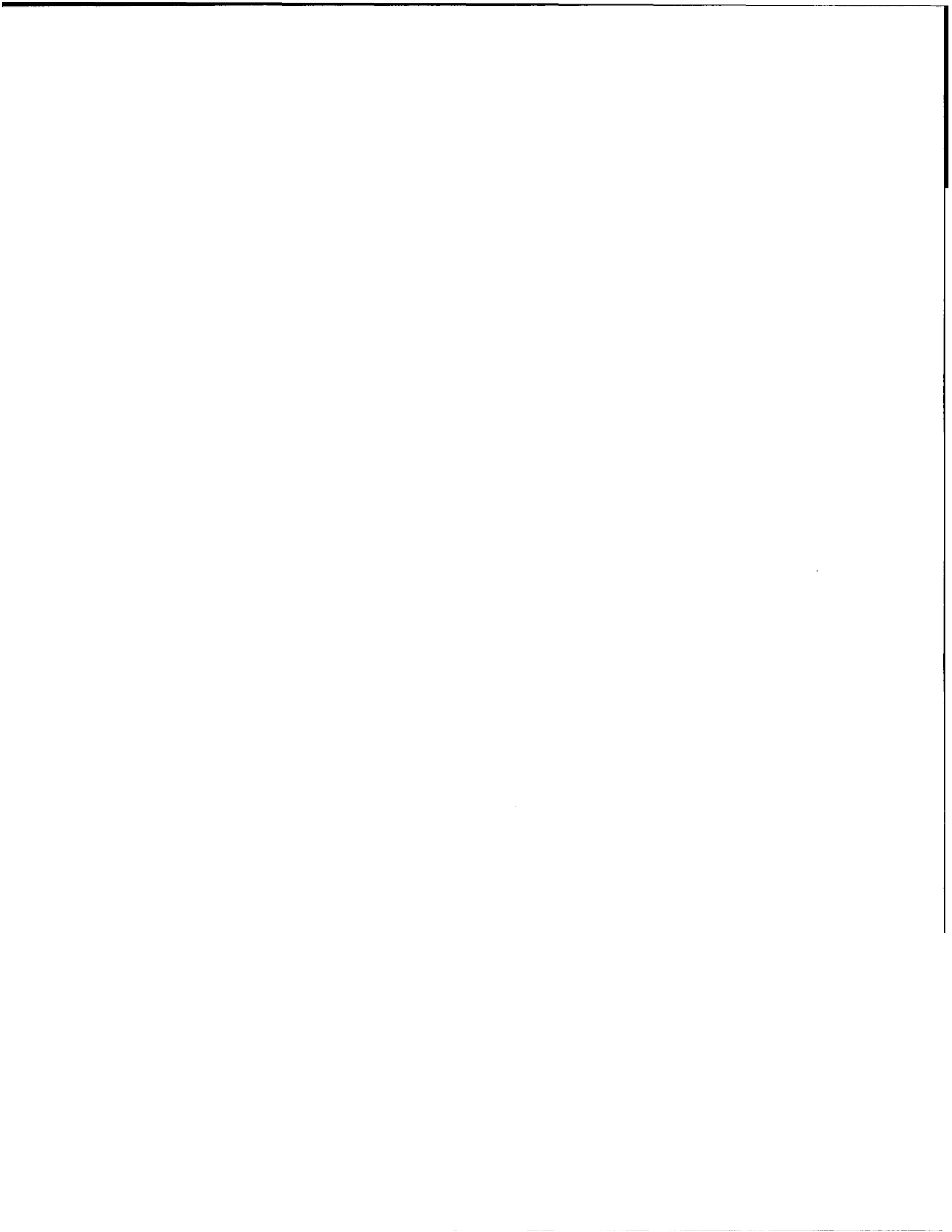



## Appendix F - System Configuration Diagram

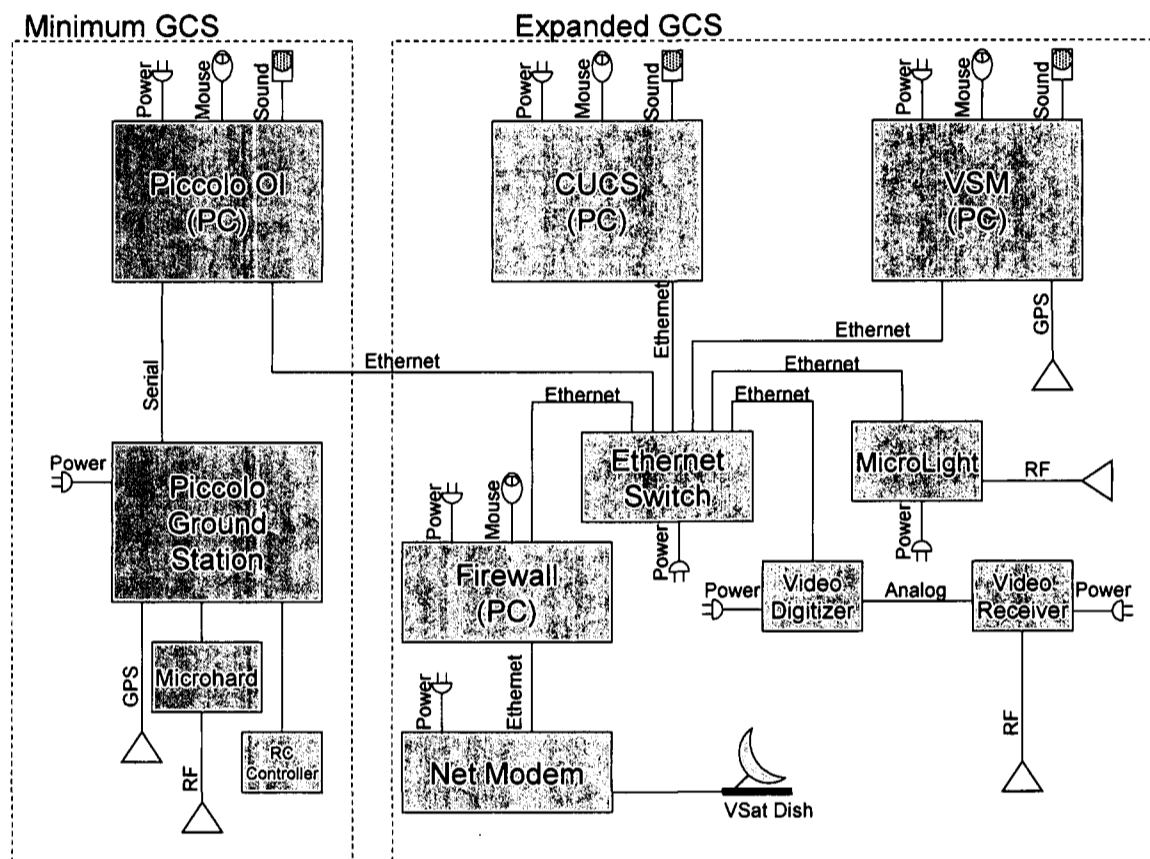

### A Minimum GCS

This is the basic Cloud Cap Piccolo Ground Station delivered by the autopilot manufacturer. Can operate as a stand alone Ground Control Unit, or be expanded via ethernet connection. External power is provide by a 1500 watt Uninterruptible Power Supply (UPS) (not shown).

<http://www.cloudcaptech.com/>

#### 1 Piccolo Operator Interface (OI)

- (a) Pilot and Sensor interface (software) running on a laptop PC. Windows Operating System. Connects to Piccolo Ground Station Module via serial interface.
- (b) Laptop contains battery backup.
- (c) Connects to Expanded GCS via Ethernet.

#### 2 Piccolo Ground Station (Module)



# Raytheon

- (a) An enclosed 8x6x4 hardware unit consisting of a Piccolo Autopilot Card, GPS, Microhard Transmitter/Receiver, and internal battery backup.
- (b) Connects to and provides power for the RC controller, and provides external antenna connections.

### 3 Microhard Datalink

- (a) Internal to the Piccolo Ground Station Module. Provides 1 watt transmit and receive on 900 MHz spread spectrum datalink.
- (b) Passes command and control inputs to, and receives telemetry data from the aircraft
- (c) <http://www.microhardcorp.com/>

### 4 RC Controller

- (a) A standard off the shelf Remote Control (RC) model controller with the battery and TX/RX module removed. Connected to the Ground Station module via the buddy cord interface. Receives power from the Ground Station module. Provides manual pilot control of the aircraft, and switches from manual to automatic control.
- (b) Is not required for system function. If disconnected, and configured correctly, the system defaults to automatic.

## B Expanded GCS

Multi-Vehicle Control System (MVCS), MicroLight datalink, extended communications and video processing. External power is provide by a 1500 watt UPS (not shown).

### 1 Common UAS Control System (CUCS)

- (a) Sub-component of the MVCS
- (b) One of two STANAG 4586 compliant modules. Pilot and Sensor interface (software) running on a laptop PC. Linux Red Hat Operating System. Connects to Piccolo OI via ethernet interface.
- (c) Can run on the same laptop as the VSM or independently.
- (d) Multiple CUCS can be connected via the ethernet hub to provide additional pilot or sensor controls.
- (e) STANAG 4586 – NATO standard for UAS communications
- (f) Laptop contains battery backup.
- (g) Can be configured to use the Microhard datalink or the MicroLight datalink.

### 2 Vehicle Specific Module (VSM)

- (a) Sub-component of the MVCS
- (b) Second of two STANAG 4586 compliant modules. Telemetry interface (software) running on a laptop PC on an airborne processor. Linux Red Hat Operating System. Connects to CUCS via ethernet interface or to aircraft via datalink.
- (c) Can run on the same laptop as the CUCS or independently.

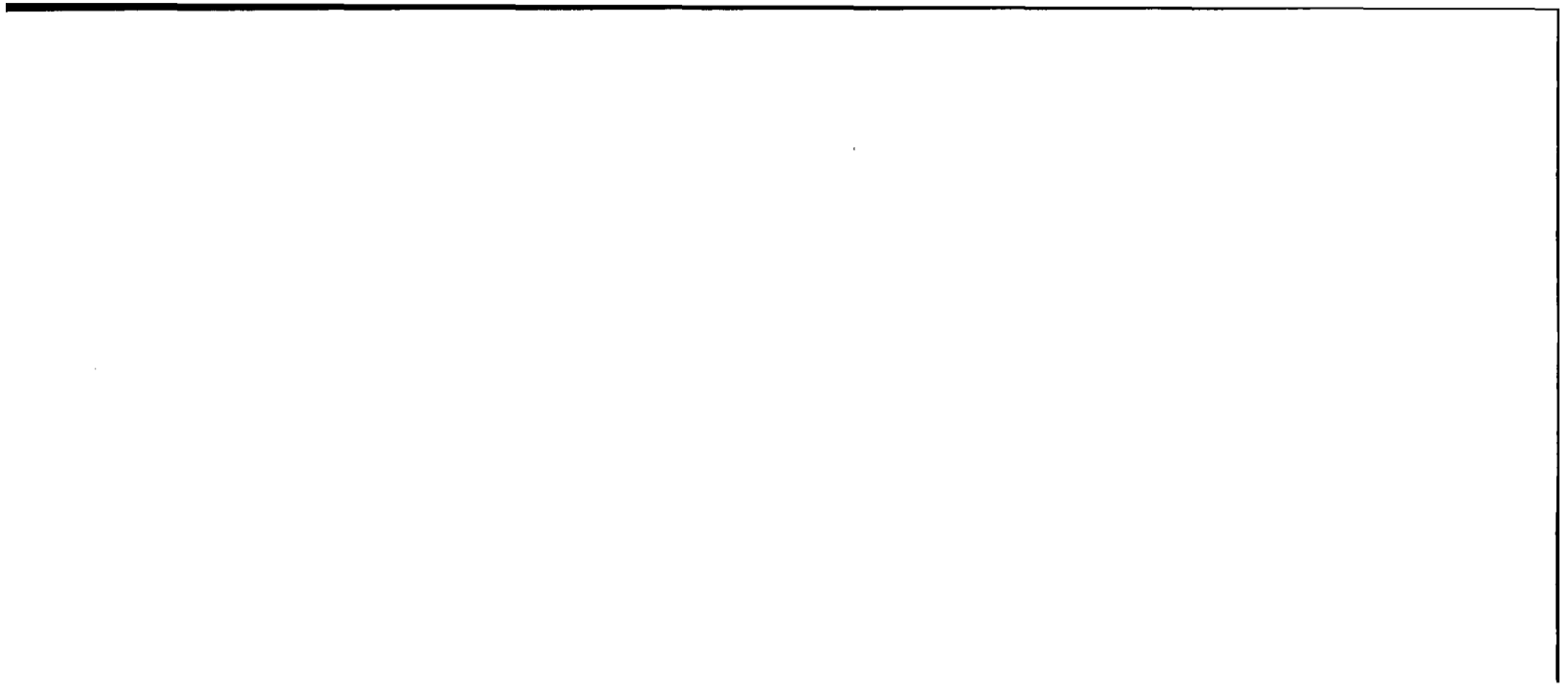

---

# Raytheon

(d) Can be hosted on the ground or in the aircraft.

(e) Laptop contains battery backup.

### 3 Ethernet Switch

(a) Gigabit ethernet switch provides communications pathway between elements.

### 4 MicroLight

(a) Raytheon produced software radio, used as a digital networked datalink.

(b) <http://www.raytheon.com/products/microlight/>

### 5 Firewall PC

(a) Laptop running firewall application to allow secure connection to Raytheon Intranet.

### 6 Net Modem

(a) Provides connection to VSat Commercial Satellite Link

### 7 VSat

(a) Provides commercial satellite connection to Raytheon Intranet.

(b) Can be used to disseminate UAS telemetry and sensor imagery.

(c) Can be used to receive weather, maps, mission plans and track data.

### 8 Video Digitizer

(a) Digitizes analog video signal to digital output for viewing and dissemination.

### 9 Video Receiver

(a) Receives analog video signal from the aircraft.

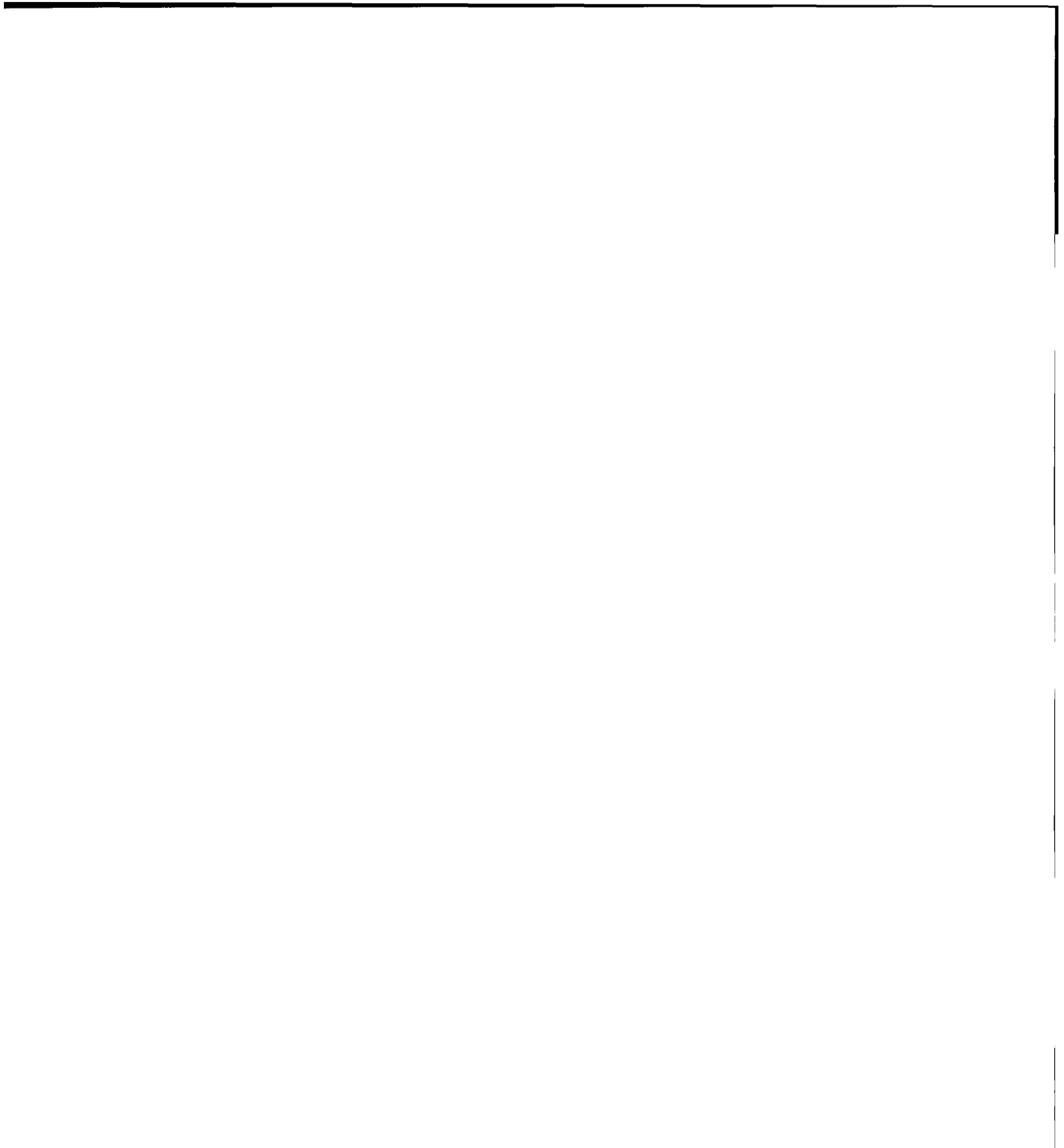

**Raytheon**

*Appendix G - FAA UAS Safety Checklist*

Separate Document

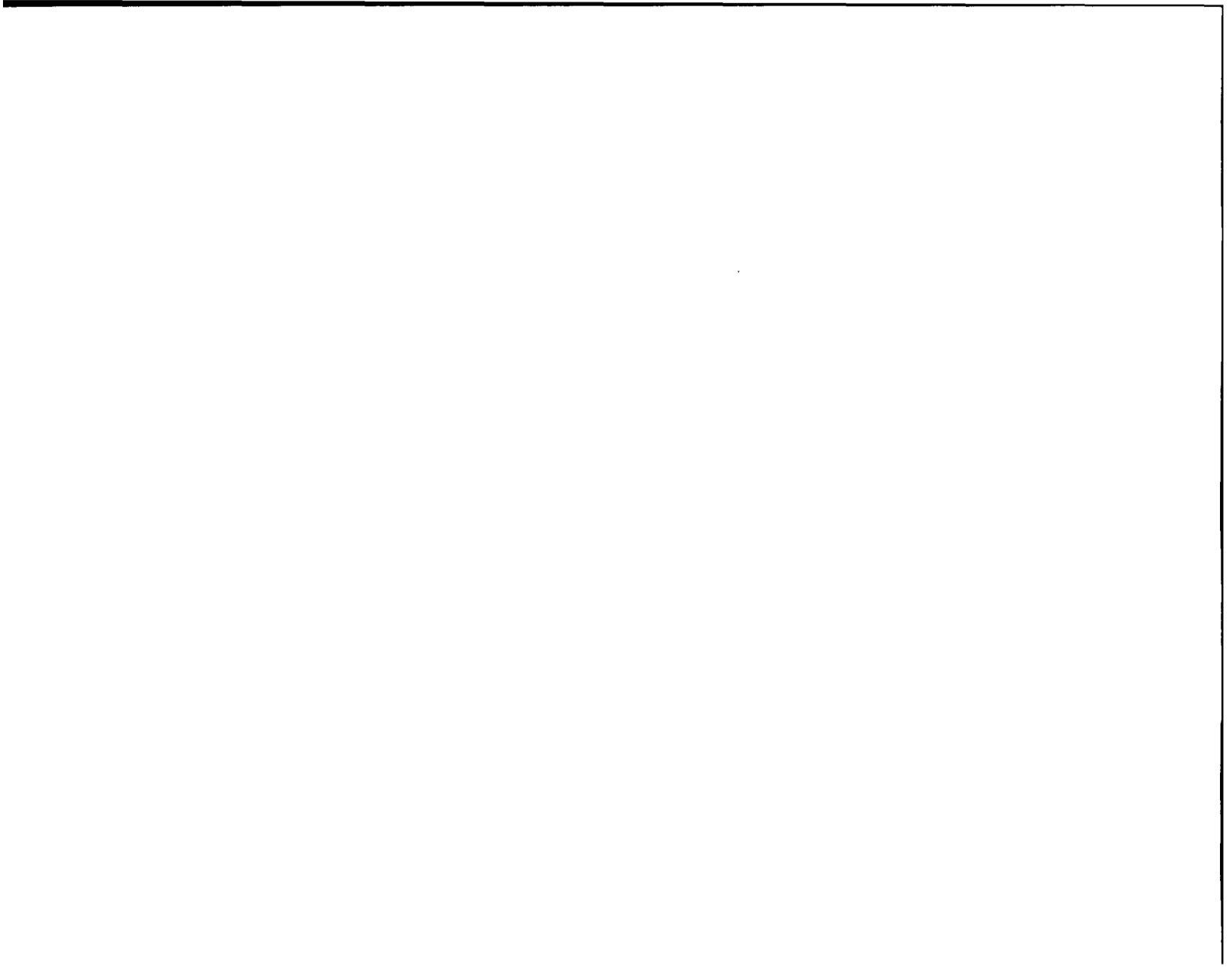



## Appendix H – Acronym List

<b>A</b>		<b>I</b>	
AGL		IFR	
Above Ground Level .....	4	Instrument Flight Rules .....	5
ATIS		IP	
Automatic Terminal Information Service .....	20	Internal Pilot .....	17
<b>C</b>		<b>J</b>	
CFR		JTRS	
Code of Federal Regulations .....	3	Joint Tactical Radio System .....	14
COTS			
Commercial Off-The-Shelf .....	13		
CUCS			
Core UAV Control Station .....	14		
<b>D</b>		<b>K</b>	
DAFIF		CIAS	
Digital Aeronautical Information File .....	24	Knots Indicated Airspeed .....	7
DGPS		KTS	
Differential Global Positioning System .....	13	Knots .....	7
DoD			
Department of Defense .....	4		
DR			
Dead Reckoning .....	22		
<b>E</b>		<b>L</b>	
ECHUM		LUAV	
Electronic Chart Updating Manual .....	24	Lethal Unmanned Aerial Vehicle .....	18
EMI			
Electro-Magnetic Interference .....	7		
EP			
External Pilot .....	5		
EPLRS			
Enhanced Position Location Reporting System .....	14		
<b>F</b>		<b>M</b>	
FAA		MAV	
Federal Aviation Administration .....	4	Micro Air Vehicle .....	18
FCC		MEL	
Federal Communications Commission .....	7	Minimum Equipment List .....	32
		MEMS	
		Micro-Electro-Mechanical Systems .....	12
		MFD	
		Multi-Function Display .....	14
		MHX	
		Multi-Plex .....	13
		MHz	
		Mega-Hertz .....	14
		MOA	
		Military Operating Area .....	5
		MRA	
		Minimum Reception Altitude .....	5
		MSL	
		Mean Sea Level .....	4
		MVCS	
		Multi-Vehicle Control System .....	15
<b>G</b>		<b>N</b>	
GCS		NOTAM	
Ground Control Station .....	20	Notice to Airmen .....	4
GHz			
Giga-Hertz .....	13		
GPS			
Global Positioning System .....	12		

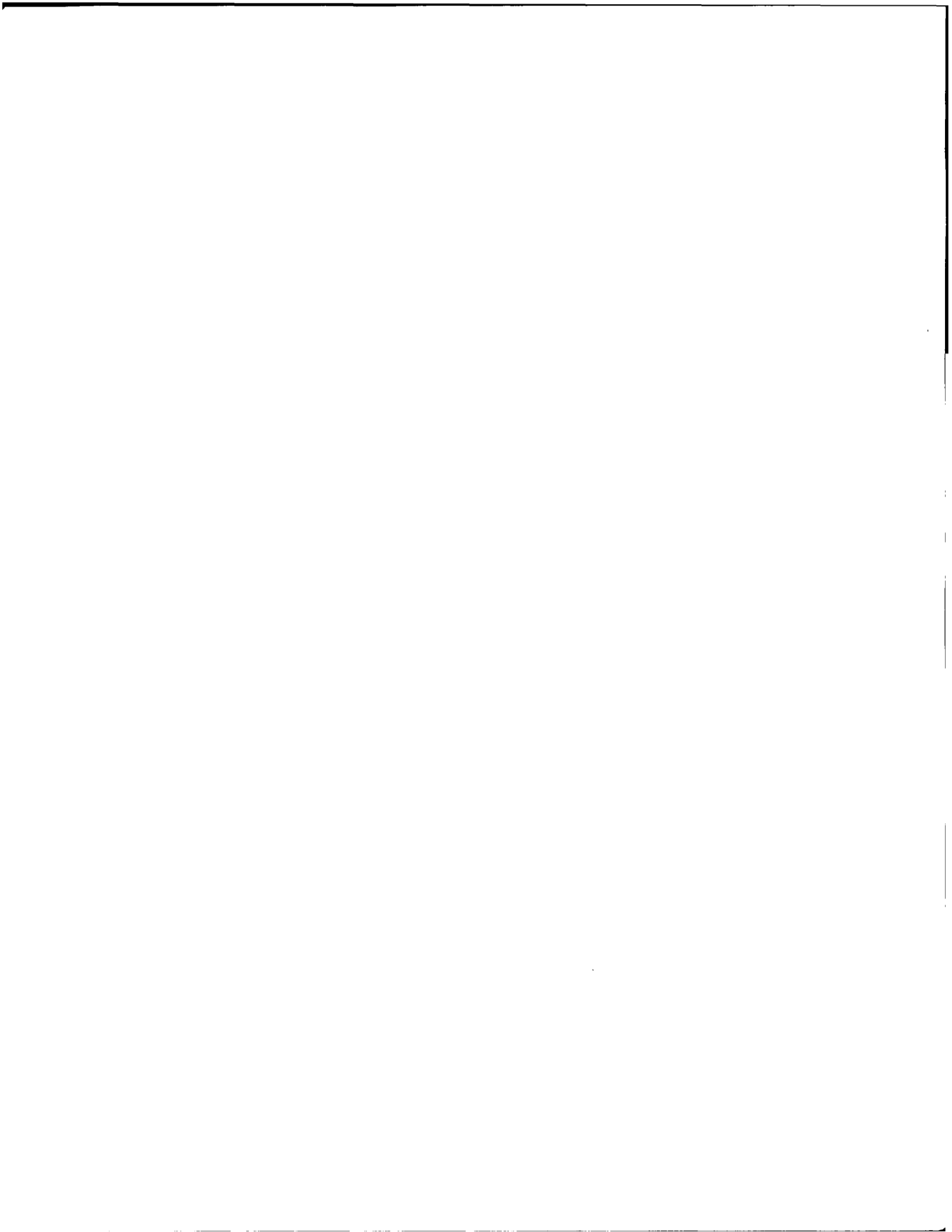

# Raytheon

<b>O</b>	
OI	
Operator Interface .....	24
<b>P</b>	
PFD	
Primary Flight Display .....	14
PFPS	
DoD Portable Flight Planning System .....	24
PIC	
Pilot in Command .....	17
<b>R</b>	
RC	
Remote Control .....	17
RFI	
Radio Frequency Interference .....	7
RX	
Receive .....	37
<b>S</b>	
SE	
Southeast .....	5
SP	
Supplemental Pilot .....	17
STANAG	
NATO Standardizaion Agreement .....	14
SUAV	
Small Unmanned Aerial Vehicle .....	18
SW	
Southwest .....	5

<b>T</b>	
TRR	
Test Readiness Review .....	16
TX	
Transmit .....	37
<b>U</b>	
UA	
Unmanned Aircraft .....	<i>Unmanned Aircraft System</i>
UAS	
Unmanned Aircraft System .....	2
UAV	
Unmanned Aerial Vehicle .....	14
UHF	
Ultra High Frequency .....	13
UPS	
Uninterruptible Power Supply .....	36
UVI	
Unmanned Vehicles International .....	3
<b>V</b>	
VFR	
Visual Flight Rules .....	7
VHF	
Very High Frequency .....	24
VMC	
Visual Meteorological Conditions .....	7
VR	
Military VFR Training Route .....	5
VSM	
Vehicle Specific Module .....	14

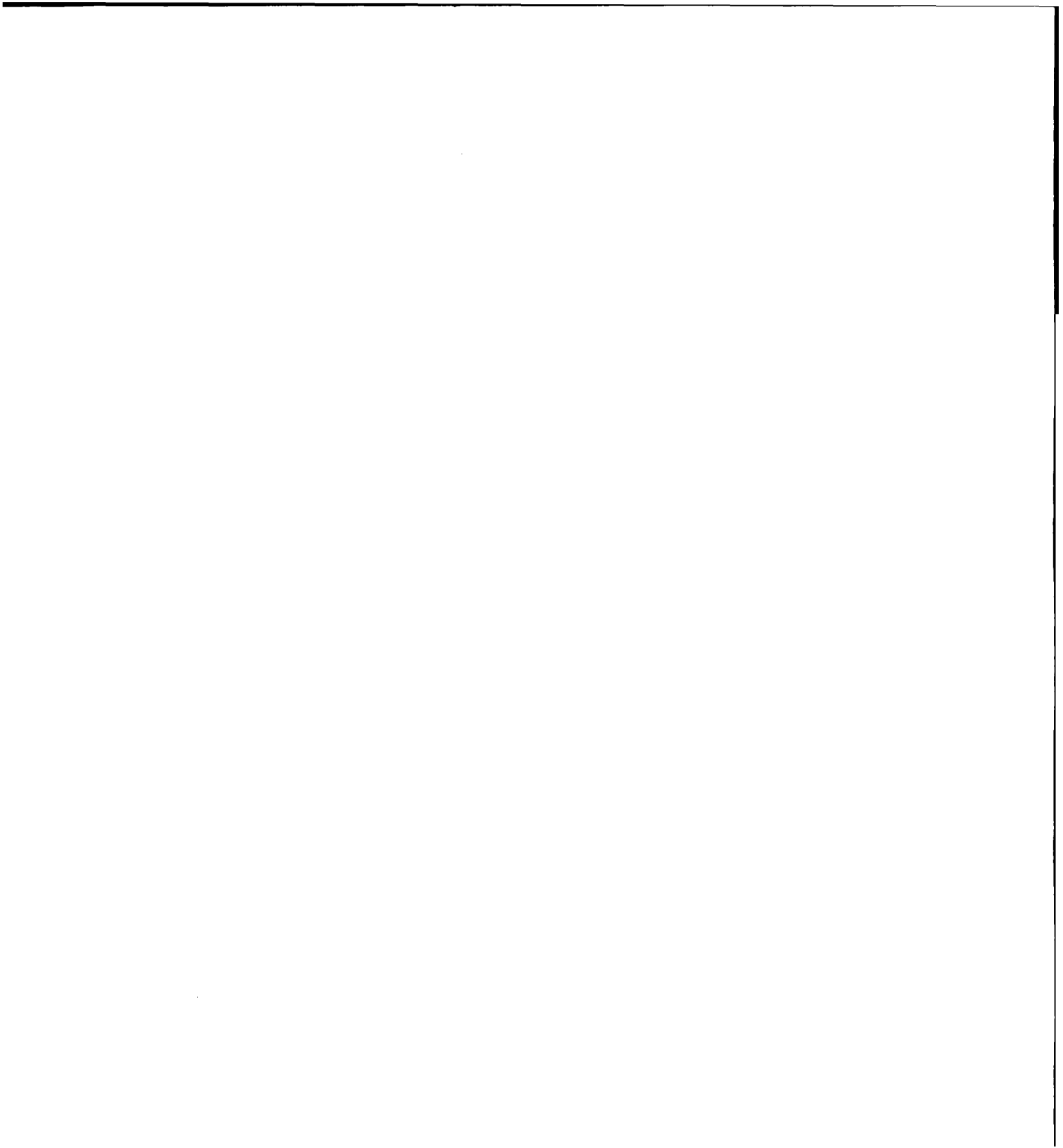

**Raytheon**



FAA FORM 8130-6, APPLICATION FOR U.S. AIRWORTHINESS CERTIFICATE

Form Approved O.M.B. No. 2120-0018  
09/30/2007

U.S. Department of Transportation Federal Aviation Administration		APPLICATION FOR U.S. AIRWORTHINESS CERTIFICATE		INSTRUCTIONS - Print or type. Do not write in shaded areas; these are for FAA use only. Submit original only to an authorized FAA Representative. If additional space is required, use attachment. For special flight permits complete Sections II, VI and VII as applicable.	
I. AIRCRAFT DESIGNATION	1. REGISTRATION MARK	2. AIRCRAFT BUILDER'S NAME (Make)	3. AIRCRAFT MODEL DESIGNATION	4. YR. MFR.	FAA CODING
	N606RN	Raytheon	Cobra	2006	061001A
	5. AIRCRAFT SERIAL NO.	6. ENGINE BUILDER'S NAME (Make)	7. ENGINE MODEL DESIGNATION	20500	
	006	Desert Aircraft	DA-150		
	8. NUMBER OF ENGINES	9. PROPELLER BUILDER'S NAME (Make)	10. PROPELLER MODEL DESIGNATION	11. AIRCRAFT IS (Check if applicable)	
	1	Mezjlick	28 x 12-3B	IMPORT	
APPLICATION IS HEREBY MADE FOR: (Check applicable items)					
A. 1 STANDARD AIRWORTHINESS CERTIFICATE (Indicate Category)					
B. <input checked="" type="checkbox"/> SPECIAL AIRWORTHINESS CERTIFICATE (Check appropriate items)					
7. PRIMARY					
9. LIGHT-SPORT (Indicate Class)					
2. LIMITED					
5. PROVISIONAL (Indicate Class)					
1. CLASS I					
2. CLASS II					
3. RESTRICTED (Indicate operation(s) to be conducted)					
1. AGRICULTURE AND PEST CONTROL					
2. AERIAL SURVEY					
3. AERIAL ADVERTISING					
4. FOREST (Wildlife Conservation)					
5. PATROLLING					
6. WEATHER CONTROL					
0. OTHER (Specify)					
4. <input checked="" type="checkbox"/> EXPERIMENTAL (Indicate operation(s) to be conducted)					
1. <input checked="" type="checkbox"/> RESEARCH AND DEVELOPMENT					
2. AMATEUR BUILT					
3. EXHIBITION					
4. AIR RACING					
5. <input checked="" type="checkbox"/> CREW TRAINING					
6. <input checked="" type="checkbox"/> MARKET SURVEY					
0. TO SHOW COMPLIANCE WITH THE CFR					
7. OPERATING (Primary Category) KIT BUILT AIRCRAFT					
8. OPERATING LIGHT-SPORT					
8A. Existing Aircraft without an airworthiness certificate & do not meet § 103.1					
8B. Operating Light-Sport Kit-Built					
8C. Operating light-sport previously issued special light-sport category airworthiness certificate under § 21.190					
8. SPECIAL FLIGHT PERMIT (Indicate operation(s) to be conducted, then complete Section VI or VII as applicable on reverse side)					
1. FERRY FLIGHT FOR REPAIRS, ALTERATIONS, MAINTENANCE, OR STORAGE					
2. EVACUATION FROM AREA OF IMPENDING DANGER					
3. OPERATION IN EXCESS OF MAXIMUM CERTIFICATED TAKE-OFF WEIGHT					
4. DELIVERING OR EXPORTING					
5. PRODUCTION FLIGHT TESTING					
6. CUSTOMER DEMONSTRATION FLIGHTS					
C. 6 MULTIPLE AIRWORTHINESS CERTIFICATE (check ABOVE "Restricted Operation" and "Standard" or "Limited" as applicable)					
III. OWNER'S CERTIFICATION					
A. REGISTERED OWNER (As shown on certificate of aircraft registration)					
NAME Raytheon Co			IF DEALER, CHECK HERE ADDRESS PO Box 11337 Tucson, AZ 85734-1337		
B. AIRCRAFT CERTIFICATION BASIS (Check applicable blocks and complete items as indicated)					
AIRCRAFT SPECIFICATION OR TYPE CERTIFICATE DATA SHEET (Give No. and Revision No.) NA			<input checked="" type="checkbox"/> AIRWORTHINESS DIRECTIVES (Check if all applicable AD's are complied with and give the number of the last AD SUPPLEMENT available in the biweekly series as of the date of application) AD Bi-Weekly # 2007-18		
AIRCRAFT LISTING (Give page number(s)) NA			SUPPLEMENTAL TYPE CERTIFICATE (List number of each STC incorporated) NA		
C. AIRCRAFT OPERATION AND MAINTENANCE RECORDS					
CHECK IF RECORDS IN COMPLIANCE WITH 14 CFR Section 91.417		TOTAL AIRFRAME HOURS		EXPERIMENTAL ONLY (Enter hours flown since last certificate issued or renewed)	
		0		3 0	
D. CERTIFICATION - I hereby certify that I am the registered owner (or his agent) of the aircraft described above, that the aircraft is registered with the Federal Aviation Administration in accordance with Title 49 of the United States Code 44101 et seq. and applicable Federal Aviation Regulations, and that the aircraft has been inspected and is airworthy and eligible for the airworthiness certificate requested.					
DATE OF APPLICATION 092707		NAME AND TITLE (Print or type) Donald L. Newman, Director, Unmanned Systems		SIGNATURE <i>Donald L. Newman</i>	
IV. INSPECTION AGENCY VERIFICATION					
A. THE AIRCRAFT DESCRIBED ABOVE HAS BEEN INSPECTED AND FOUND AIRWORTHY BY: (Complete the section only if 14 CFR part 21.183(d) applies.)					
14 CFR part 121 CERTIFICATE HOLDER (Give Certificate No.)		CERTIFICATED MECHANIC (Give Certificate No.)		CERTIFICATED REPAIR STATION (Give Certificate No.)	
2		3		6	
5. AIRCRAFT MANUFACTURER (Give name or firm)					
DATE		TITLE		SIGNATURE	
V. FAA REPRESENTATIVE CERTIFICATION					
(Check ALL applicable block items A and B)					
A. I find that the aircraft described in Section I or VII meets requirements for				<input checked="" type="checkbox"/> THE CERTIFICATE REQUESTED	
B. Inspection for a special permit under Section VII was conducted by:				<input type="checkbox"/> AMENDMENT OR MODIFICATION OF CURRENT AIRWORTHINESS CERTIFICATE	
DATE		DISTRICT OFFICE		DESIGNEE'S SIGNATURE AND NO.	
10/26/2007		PHOENIX M100 NM-50		4. <i>Bradley R. Roop</i>	
				1. FAA INSPECTOR'S SIGNATURE <i>Bradley R. Roop</i>	

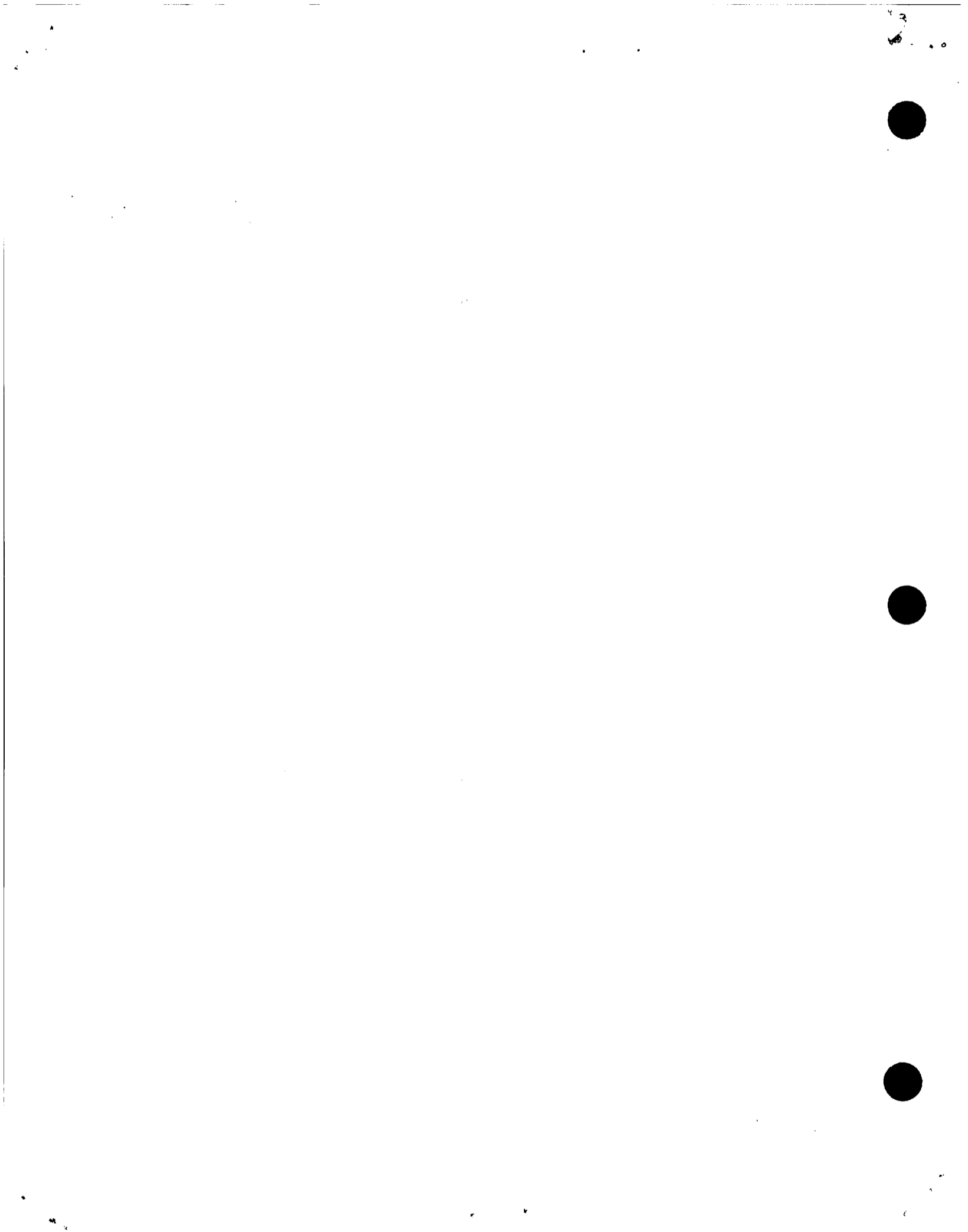



<b>VI. PRODUCTION FLIGHT TESTING</b>	A. MANUFACTURER							
	NAME		ADDRESS					
	B. PRODUCTION BASIS <i>(Check applicable item)</i>							
	<input type="checkbox"/>		PRODUCTION CERTIFICATE <i>(Give production certificate number)</i> →					
	<input type="checkbox"/>		TYPE CERTIFICATE ONLY					
<input type="checkbox"/>		APPROVED PRODUCTION INSPECTION SYSTEM						
C. GIVE QUANTITY OF CERTIFICATES REQUIRED FOR OPERATING NEEDS								
DATE OF APPLICATION		NAME AND TITLE <i>(Print or Type)</i>		SIGNATURE				
<b>VII. SPECIAL FLIGHT PERMIT PURPOSES OTHER THAN PRODUCTION FLIGHT TEST</b>	A. DESCRIPTION OF AIRCRAFT							
	REGISTERED OWNER		ADDRESS					
	BUILDER <i>(Make)</i>		MODEL					
	SERIAL NUMBER		REGISTRATION MARK					
	B. DESCRIPTION OF FLIGHT							
	FROM		TO					
	VIA		DEPARTURE DATE	DURATION				
	C. CREW REQUIRED TO OPERATE THE AIRCRAFT AND ITS EQUIPMENT							
	<input type="checkbox"/>	PILOT	<input type="checkbox"/>	CO-PILOT	<input type="checkbox"/>	FLIGHT ENGINEER	<input type="checkbox"/>	OTHER <i>(Specify)</i>
	D. THE AIRCRAFT DOES NOT MEET THE APPLICABLE AIRWORTHINESS REQUIREMENTS AS FOLLOWS:							
	E. THE FOLLOWING RESTRICTIONS ARE CONSIDERED NECESSARY FOR SAFE OPERATION: <i>(Use attachment if necessary)</i>							
	F. CERTIFICATION – I hereby certify that I am the registered owner (or his agent) of the aircraft described above; that the aircraft is registered with the Federal Aviation Administration in accordance with Title 49 of the United States Code 44101 <u>et seq.</u> , and applicable Federal Aviation Regulations; and that the aircraft has been inspected and is safe for the flight described.							
	DATE		NAME AND TITLE <i>(Print or Type)</i>		SIGNATURE			
<b>VIII. AIRWORTHINESS DOCUMENTATION (FAA/DESIGNEE USE ONLY)</b>	<input checked="" type="checkbox"/>	A. Operating Limitations and Markings in Compliance with 14 CFR Section 91.9, as applicable.		G. Statement of Conformity, FAA Form 8130-9 <i>(Attach when required)</i>				
	<input checked="" type="checkbox"/>	B. Current Operating Limitations Attached		H. Foreign Airworthiness Certification for Import Aircraft <i>(Attach when required)</i>				
	<input checked="" type="checkbox"/>	C. Data, Drawings, Photographs, etc. <i>(Attach when required)</i>		I. Previous Airworthiness Certificate Issued in Accordance with 14 CFR Section _____ CAR _____ <i>(Original Attached)</i>				
	<input checked="" type="checkbox"/>	D. Current Weight and Balance information Available in Aircraft						
	<input checked="" type="checkbox"/>	E. Major Repair and Alteration, FAA Form 337 <i>(Attach when required)</i>		J. Current Airworthiness Certificate Issued in Accordance with 14 CFR Section <u>21.191(a)(2)(f)</u> <i>(Copy Attached)</i>				
	<input checked="" type="checkbox"/>	F. This inspection Recorded in Aircraft Records		K. Light-Sport Aircraft Statement of Compliance, FAA Form 8130-15 <i>(Attach when required)</i>				

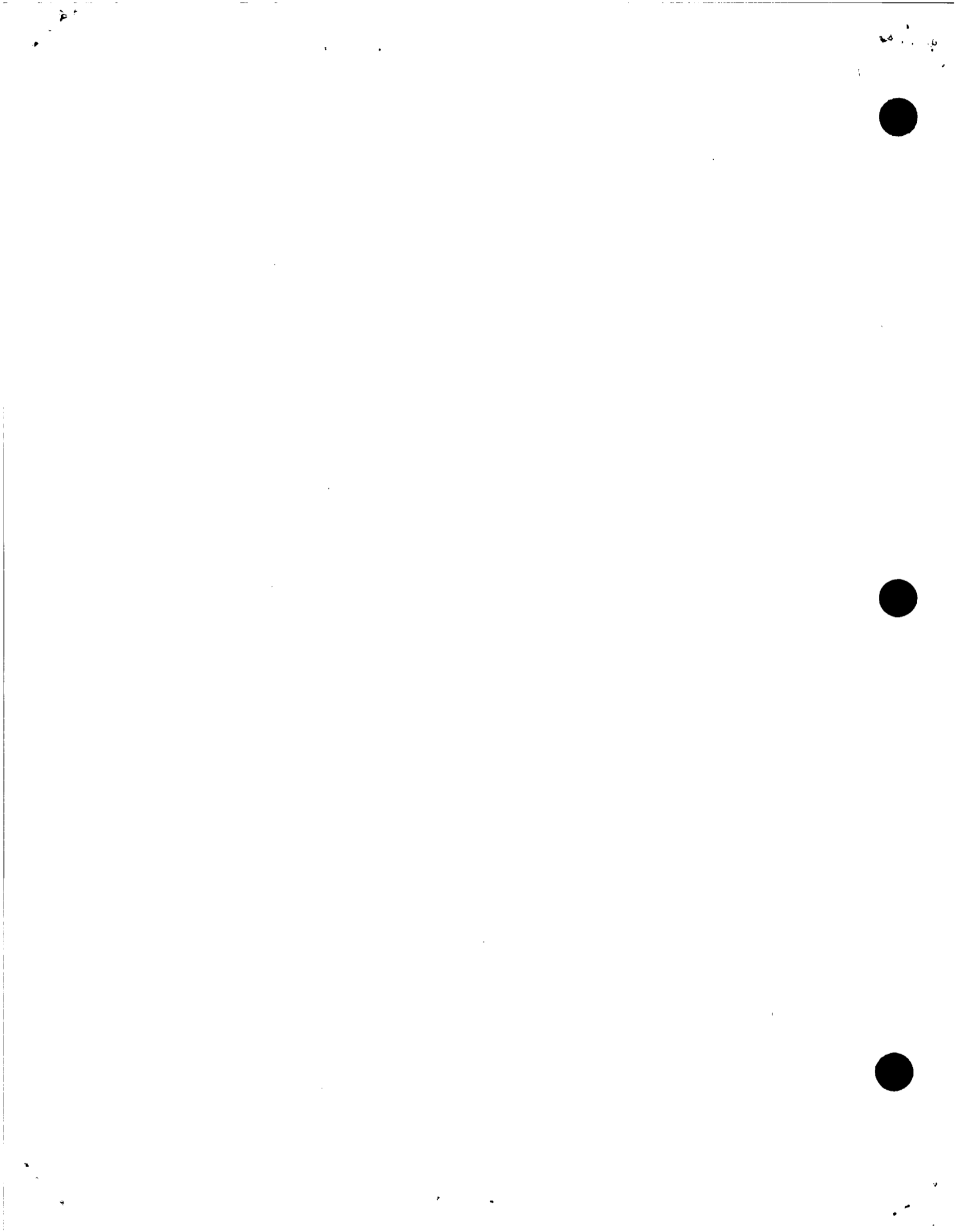

UNITED STATES OF AMERICA  
 DEPARTMENT OF TRANSPORTATION - FEDERAL AVIATION ADMINISTRATION  
**SPECIAL AIRWORTHINESS CERTIFICATE**

<b>A</b>	CATEGORY/DESIGNATION		Experimental (Unmanned Aircraft)
	PURPOSE		
<b>B</b>	MANUFACTURER	NAME	N/A
		ADDRESS	N/A
<b>C</b>	FLIGHT	FROM	N/A
		TO	N/A
<b>D</b>	N- 606RN		SERIAL NO. 006
	BUILDER	Ratheon Company	MODEL Cobra
<b>E</b>	DATE OF ISSUANCE		October 26, 2007
	OPERATING LIMITATIONS DATED		10/26/07
<b>E</b>	SIGNATURE OF FAA REPRESENTATIVE		DESIGNATION OR OFFICE NO.
	Bradley Roop		Phoenix MIDO NM-50

Any alteration, reproduction or misuse of this certificate may be punishable by a fine not exceeding \$1,000 or imprisonment not exceeding 3 years, or both. THIS CERTIFICATE MUST BE DISPLAYED IN THE AIRCRAFT IN ACCORDANCE WITH APPLICABLE TITLE 14, CODE OF FEDERAL REGULATIONS (CFR).

<b>A</b>	This airworthiness certificate is issued under the authority of Public Law 104-6, 49 United States Code (USC) 44704 and Title 14 Code of Federal Regulations (CFR).
<b>B</b>	The airworthiness certificate authorizes the manufacturer named on the reverse side to conduct production flight tests, and only production flight tests, of aircraft registered in his name. No person may conduct production flight tests under this certificate: (1) Carrying persons or property for compensation or hire; and/or (2) Carrying persons not essential to the purpose of the flight.
<b>C</b>	This airworthiness certificate authorizes the flight specified on the reverse side for the purpose shown in Block A.
<b>D</b>	This airworthiness certificate certifies that as of the date of issuance, the aircraft to which issued has been inspected and found to meet the requirements of the applicable CFR. The aircraft does not meet the requirements of the applicable comprehensive and detailed airworthiness code as provided by Annex 8 to the Convention On International Civil Aviation. No person may operate the aircraft described on the reverse side: (1) except in accordance with the applicable CFR and in accordance with conditions and limitations which may be prescribed by the Administrator as part of this certificate; (2) over any foreign country without the special permission of that country.
<b>E</b>	Unless sooner surrendered, suspended, or revoked, this airworthiness certificate is effective for the duration and under the conditions prescribed in 14 CFR, Part 21, Section 21.181 or 21.217.



U.S. Department  
of Transportation  
**Federal Aviation  
Administration**

Phoenix Manufacturing Inspection District Office  
13951 N. Scottsdale Rd. #123  
Scottsdale, AZ 85254

**EXPERIMENTAL - OPERATING LIMITATIONS**  
**RESEARCH AND DEVELOPMENT, CREW TRAINING and/or MARKET SURVEY.**

<b>REGISTERED OWNER NAME:</b> RAYTHEON MISSILE SYSTEMS	<b>AIRCRAFT BUILDER:</b> RAYTHEON MISSILE SYSTEMS
<b>REGISTERED OWNER ADDRESS:</b> PO BOX 11337 TUCSON, AZ 85734-1337	<b>YEAR MANUFACTURED:</b> 2006
<b>AIRCRAFT DESCRIPTION:</b> FIXED WING	<b>AIRCRAFT SERIAL NUMBER:</b> 006
<b>AIRCRAFT REGISTRATION:</b> N606RN	<b>AIRCRAFT MODEL DESIGNATION:</b> COBRA
	<b>ENGINE MODEL:</b> DESERT AIRCRAFT DA-150

**The following conditions and limitations apply to all Raytheon Missile Systems, Cobra Unmanned Aircraft System flight operations, while operating in the National Airspace System (NAS). These conditions and limitations must be accessible to the pilot in command at all times.**

**1. GENERAL:**

a. For the purposes of this **Special Airworthiness Certificate and Operating Limitations**, the Cobra Unmanned Aircraft System (UAS), owned and operated by Raytheon, is considered to be an integrated system. This integrated system is composed of the Cobra aircraft, S/N 006, unmanned aircraft (UA) pilot(s), UA control station(s) (fixed or mobile), telemetry, navigation and communications equipment to include ground and airborne equipment that is used for control of the Cobra UA. The ground equipment used for communication with the chase aircraft and Air Traffic Control during UAS operations is considered part of the UAS.

b. Unless otherwise specified in this document, the UA Pilot-in-Command (PIC) and Raytheon shall comply with all applicable sections and parts of 14 CFR including, but not limited to, parts 61 and 91. Alternative methods of compliance with specific regulations shall be annotated in this document as required.

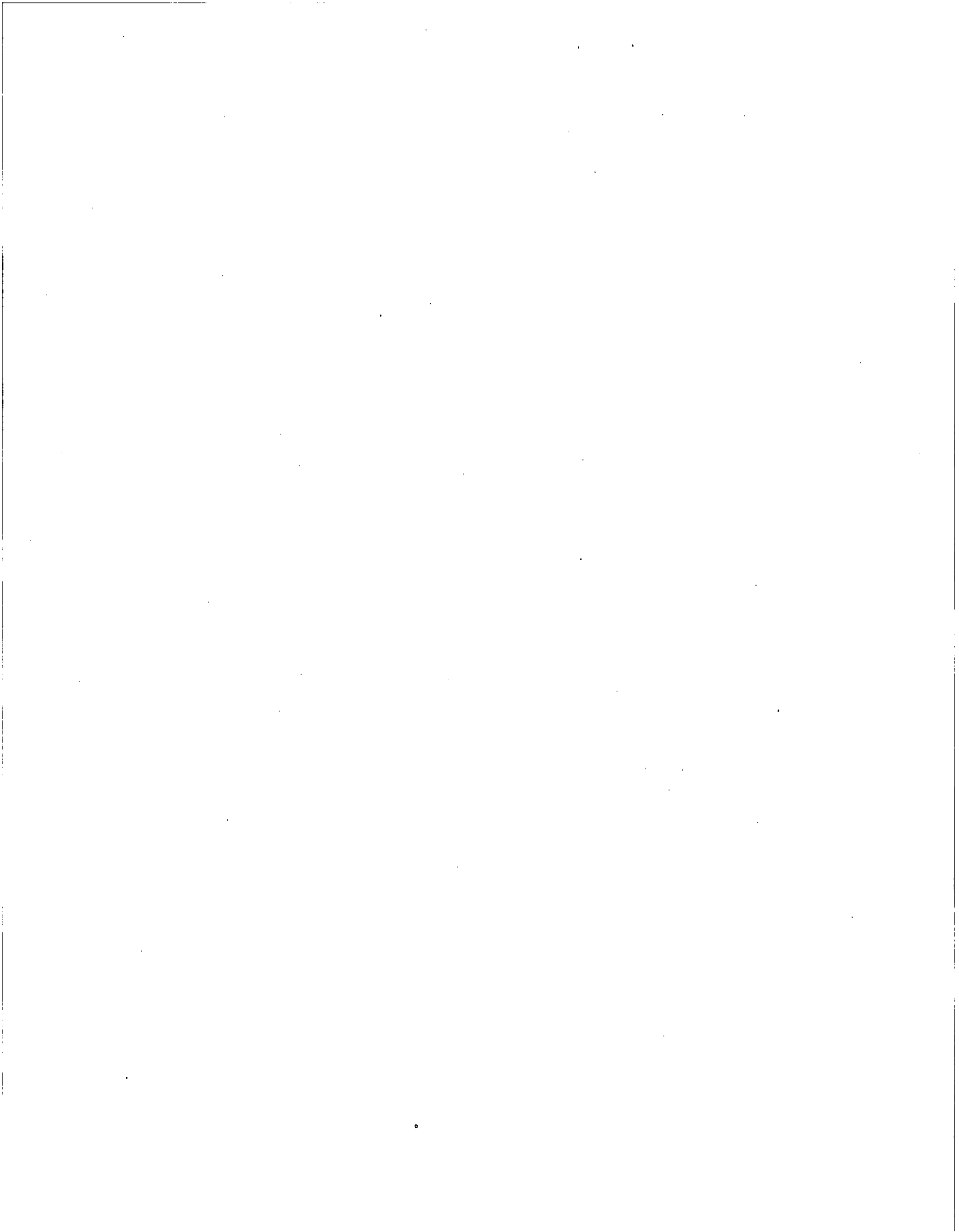

October 26, 2007

c. No person may operate this UA for other than the purpose of Research and Development, Crew Training and/or Market Survey, to accomplish the flight operations outlined in Raytheon Program Letter dated September 27, 2007, which describes compliance with § 21.193(d), and has been made available to the pilot in command of the UA. In addition, this UA must be operated in accordance with applicable air traffic and general operating rules of part 91, and all additional limitations herein prescribed under the provisions of § 91.319(e).

d. When changing between operating purposes of a multiple-purpose certificate, the operator must determine that the aircraft is in a condition for safe operation and appropriate for the purpose intended. A record entry will be made by an appropriately rated person to document that finding in the aircraft logbook.

e. The UA PIC must determine that the UA is in a condition for safe operation and in a configuration appropriate for the purpose of the intended flight.

f. No person may operate this UA to carry property for compensation or hire.

g. This UA must be marked with its U.S. Registration number in accordance with 14 CFR part 45 or exemption thereto.

h. This UA must display the word "EXPERIMENTAL" in accordance with § 45.23(b) or exemption thereto.

i. Prior to conducting initial Cobra flight operations, Raytheon must forward a copy of the Cobra Program Letter, Special Airworthiness Certificate, and Operating Limitations to:

1) Debra Trindle FAA Air Traffic Representative, Luke and Davis-Monthan Air Force Base, AZ, (623) 856-9596, FAX: (623) 856-8339, email, [debra.trindle@luke.af.mil](mailto:debra.trindle@luke.af.mil).

2) Roger Trevino, Airspace Specialist, FAA Central Enroute Service Area, Operations Branch, AJO-2C2, [roger.trevino@faa.gov](mailto:roger.trevino@faa.gov), FAX: 817-222-5547.

j. Section 47.45 requires that the FAA Aircraft Registry must be notified within 30 days of any change in the aircraft registrant's address. Such notification is to be made by submitting AC Form 8050-1 to AFS-750 in Oklahoma City, Oklahoma.

**2. PROGRAM LETTER:** The Raytheon **Program Letter dated September 27, 2007**, shall be used as a basis for the determination of the operating limitations prescribed in this document. All flight operations must be conducted in accordance with the provisions of this document.

**3. AUTHORIZED FLIGHT OPERATIONS AREA:**

a. The base of operations for the UA shall be:

Unmanned Vehicles International, Inc  
2595 North Sagebrush Road, Whetstone, AZ





October 26, 2007

±4 Miles east of State Route 90 on State Route 82, west of  
Mile Post 56, ½ mile north. on Sagebrush Road  
T20S, R20E, Sec. 3

This is the address of the Cochise County Western Region Landfill. UVI is accessed through the landfill property.

b. The flight operations area authorized for the UA is depicted graphically below. This area shall be referred to as the "Primary Containment Area." It is recognized that Raytheon may be permitted to operate within Special Use Airspace (SUA) per authorization of the using agency. Under these circumstances, should the UA venture beyond the boundaries of the SUA (e.g. spill out), provisions of this experimental certificate shall apply, including authorization to only operate within the boundaries of the Primary Containment Area. In these circumstances, Raytheon is responsible for notifying the FAA of the breach of any operations.

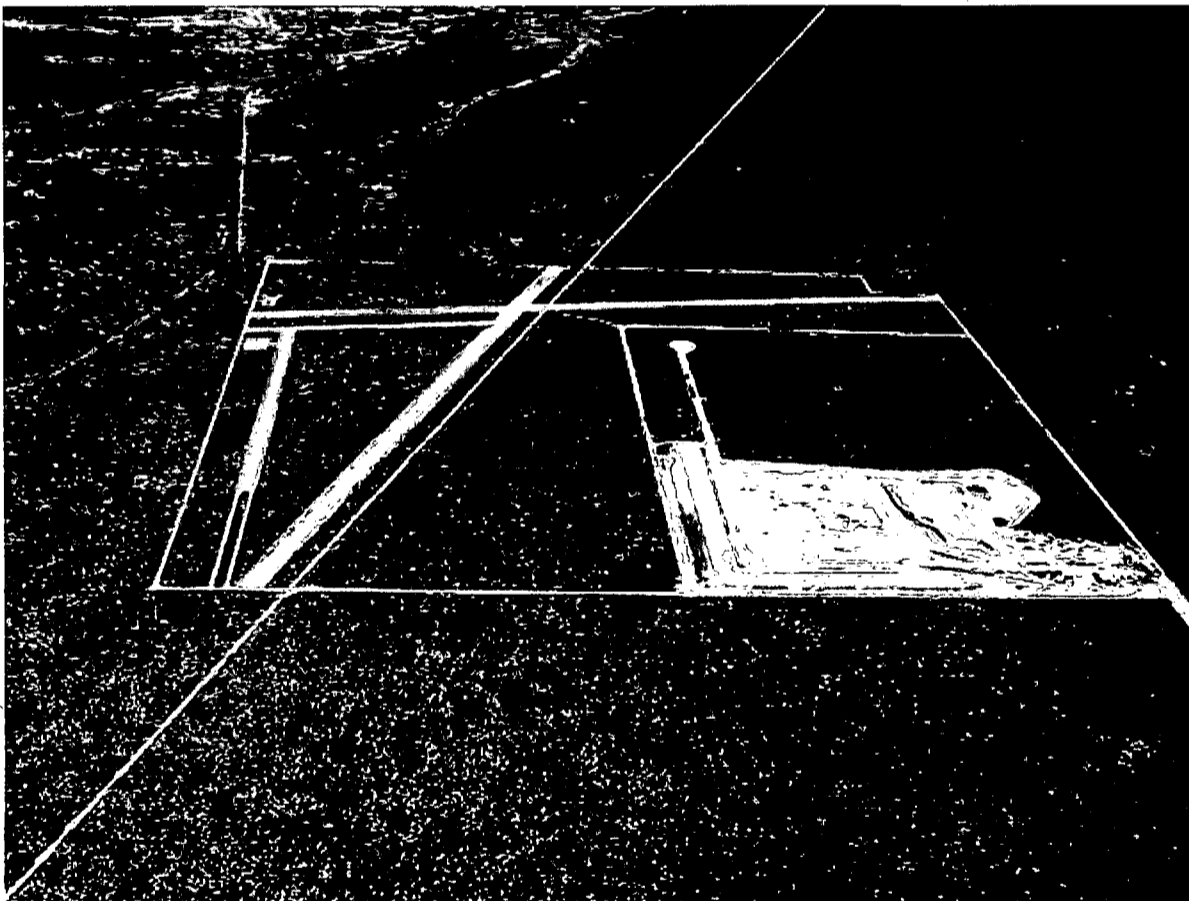
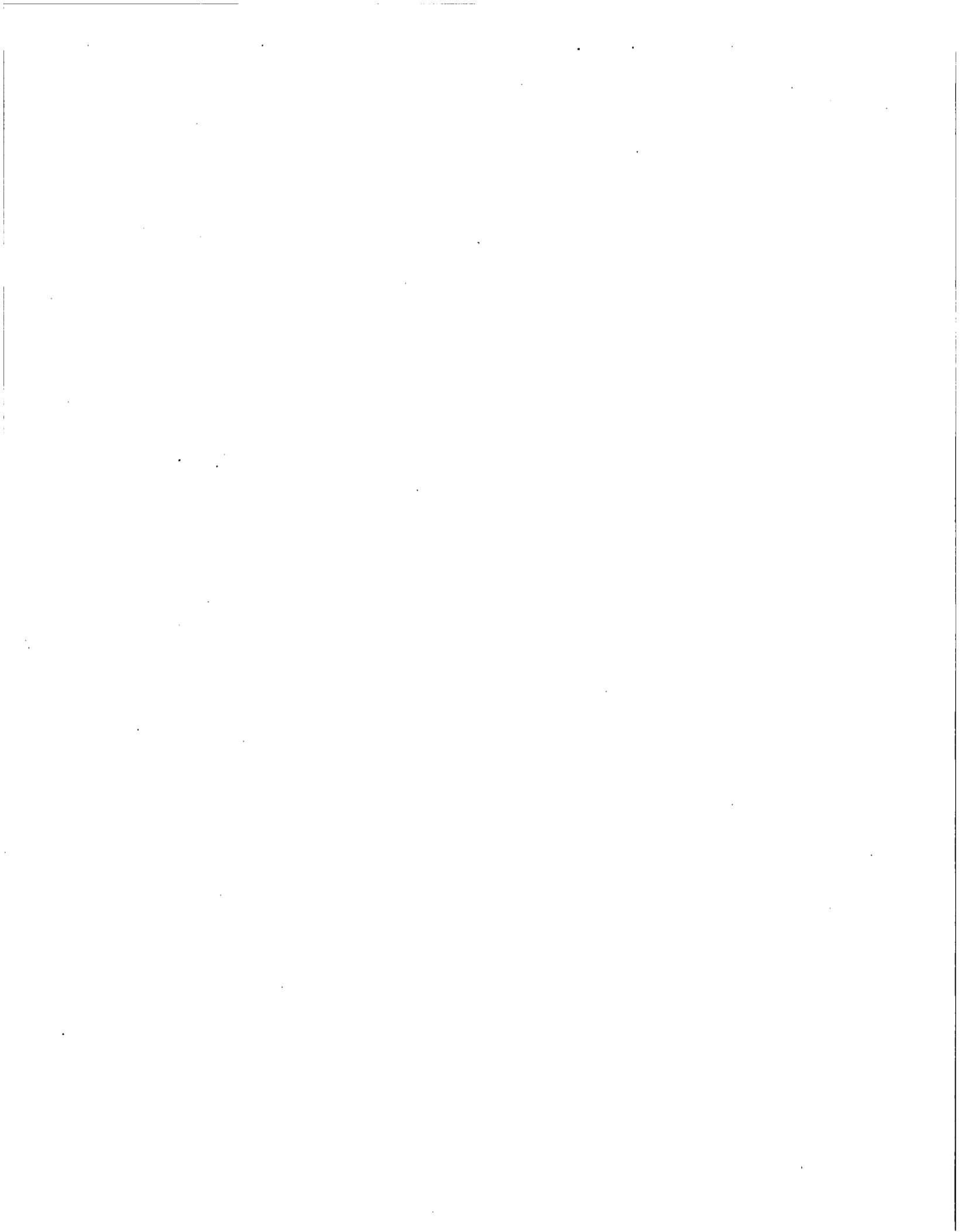

Figure 1. UVI UAS airfield looking north, located next to the Cochise County landfill.



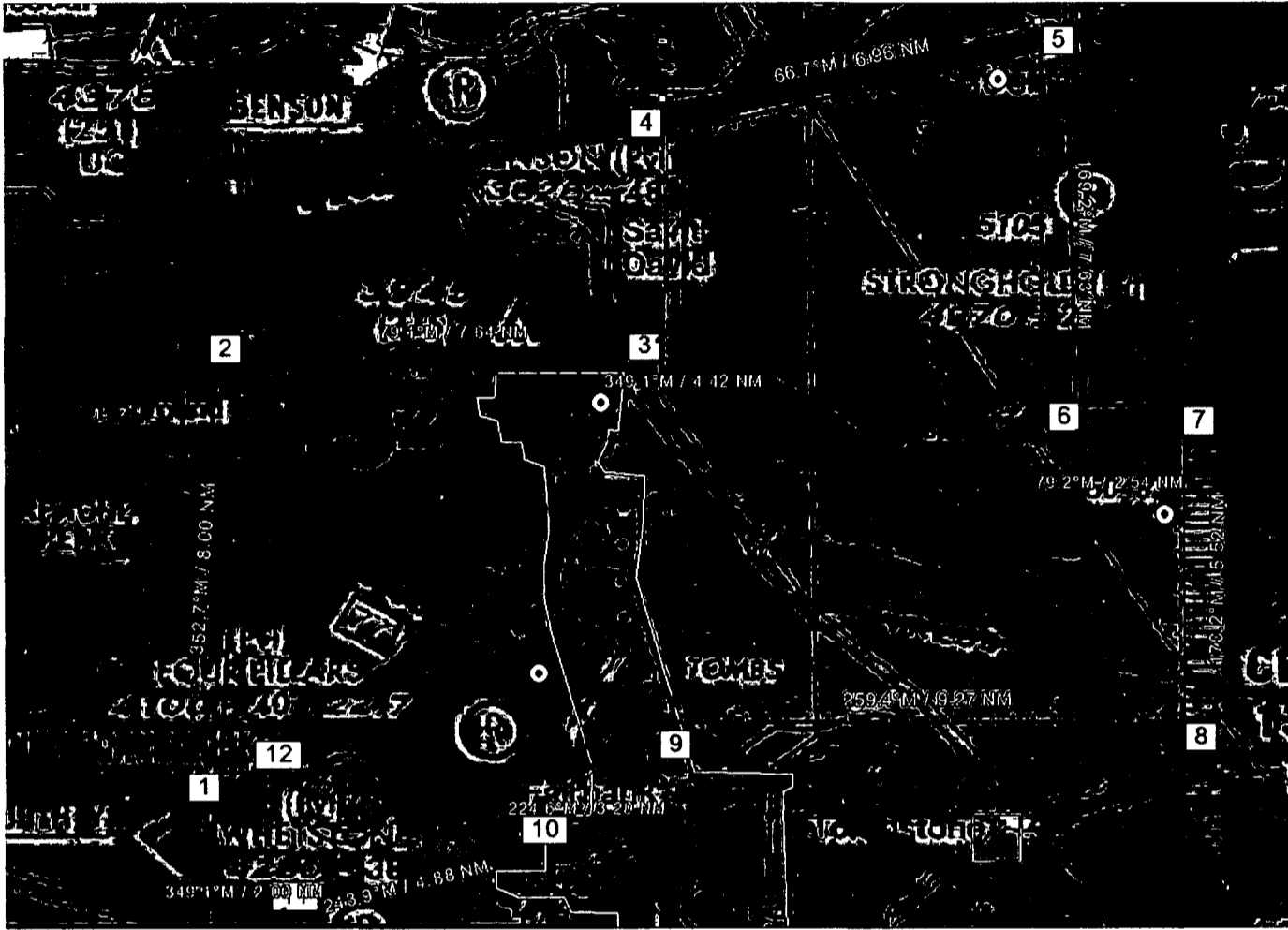

Figure 2. Phoenix Sectional, FHU 004/08.5, 4225' Elevation

N 31° 43' 30", W 110° 17' 47"

c. The boundary of the Primary Containment Area is defined by the following coordinates:

- 1) N 31° 44' 00.00" W 110° 20' 30.00"
- 2) N 31° 52' 00.00" W 110° 20' 00.00"
- 3) N 31° 52' 00.00" W 110° 11' 00.00"
- 4) N 31° 56' 30.00" W 110° 11' 00.00"
- 5) N 31° 58' 10.00" W 110° 03' 00.00"
- 6) N 31° 50' 30.00" W 110° 03' 00.00"
- 7) N 31° 50' 30.00" W 110° 00' 00.00"
- 8) N 31° 45' 00.00" W 110° 00' 00.00"
- 9) N 31° 45' 00.00" W 110° 11' 00.00"
- 10) N 31° 43' 14.00" W 110° 14' 00.00"
- 11) N 31° 42' 00.00" W 110° 19' 30.00"
- 12) N 31° 44' 00.00" W 110° 19' 30.00"
- 13) Return to 1



October 26, 2007

d. The UA PIC shall ensure that all UA flight operations remain within the lateral and vertical boundaries of the Primary Containment Area. Furthermore, the UA PIC shall take into account all factors that may affect the capability of remaining within the Primary Containment Area. This includes, but is not limited to, considerations for wind, gross weight, and glide distances.

e. Incident / Accident Reporting. Any incident / accident and any flight operation that transgresses the lateral or vertical boundaries of the Primary Containment Areas or any SUA shall be reported to the FAA, as soon as practicable, but always within 24 hours. The point of contact to report this information to the FAA is the Manager of the Unmanned Aircraft Program Office (UAPO), AIR-160, Mr. Doug Davis. Mr. Davis can be reached by phone at 202-385-4636, fax at 202-385-4651, or by e-mail at [Kenneth.d.davis@faa.gov](mailto:Kenneth.d.davis@faa.gov). Accidents shall be reported to the National Transportation Safety Board per instructions contained on the NTSB website: [www.nts.gov](http://www.nts.gov). Further flight operations shall not be conducted until the incident / accident is reviewed by ATO, AFS, and AIR-160, and authorization to resume operations is received.

#### **4. UA PILOTS and OBSERVERS:**

a. All flight operations shall have a designated UA Pilot-In-Command (PIC). Any additional UA pilot(s) assigned to a crew station during UA flight operations shall be considered a Supplemental UA Pilot. The UA PIC shall have responsibility over each flight conducted and be held accountable for the UA flight operation.

b. The UA PIC is responsible for the safety of the UA as well as persons and property along the UA flight path. This includes, but is not limited to, collision avoidance and the safety of persons and property in the air and on the ground. The UA PIC shall avoid densely populated areas (§ 91.319) and exercise increased vigilance when operating within or in the vicinity of published airway boundaries.

c. The UA PIC shall hold, at a minimum, an FAA Private Pilot certificate, with either an Airplane or Rotorcraft category, Single or Multiengine class ratings, or military equivalent, and have it in his/her possession.

d. The Supplemental Pilot need not be a certificated pilot, but must have successfully completed a recognized Private Pilot ground school or successfully completed the private pilot written test within 90 days of the date of these limitations.

e. The UA PIC shall have operational override capability over any Supplemental Pilot, regardless of position.

f. The UA PIC shall maintain currency in manned aircraft in accordance with § 61.57.

g. The UA PIC shall have a Flight Review in manned aircraft every 24 calendar months in accordance with § 61.56.

h. All UA Pilots shall maintain currency in unmanned aircraft in accordance with Cobra Unmanned Aircraft Systems Training Plan, dated 9/18/06.



i. All UA pilots shall have a Flight Review in unmanned aircraft every 24 calendar months in accordance with Raytheon company procedures.

j. All flight operations conducted in the Primary Containment Area shall have an Observer to perform traffic avoidance and visual observation to fulfill the "see and avoid" requirement of § 91.113.

k. All Observers shall:

1) Hold at a minimum, an FAA Private Pilot certificate or military equivalent (an Observer does not require currency as a pilot); or,

2) In lieu of a Pilot certificate, have successfully completed specific Observer training acceptable to the FAA.

l. All UA Pilots and Observers shall have successfully completed applicable training in accordance with, Cobra Unmanned Aircraft Systems Training Plan, dated 9/18/06.

m. The UA PIC and Observer(s) must have in their possession a valid third class (or higher) airman medical certificate that has been issued under 14 CFR part 67.

n. UA Pilots and Observers shall perform crew duties for only one UA at a time. When the Observer is located in a chase aircraft, the Observer's duties shall be dedicated to the task of observation only. Concurrent duty as pilot is not authorized.

o. All Observers must be thoroughly trained, familiar with, and possess, operational experience with the equipment being utilized for observation and detection of other aircraft for collision avoidance purposes as outlined in the Raytheon Program Letter.

p. Observer Responsibilities: The task of the Observer is to provide the UA pilot(s) with instructions to maneuver the UA clear of any potential collision with other traffic. Observer duties require continuous visual contact with the UA at all times in such a manner as to be able to discern UA attitude and trajectory in relation to conflicting traffic. To satisfy these requirements:

1) At no time shall the Observer permit the UA to operate beyond line-of-sight necessary to ensure that maneuvering information can be reliably determined.

2) At no time shall Observers conduct their duties more than one (1) nautical mile laterally or 2000 feet vertically from the UA. The maximum ceiling for flight operations is 2000 ft AGL. The small size of this particular UA may not allow for adequate observation at the 1-mile limit. It should be understood that this limit is the maximum range allowed and that a practical distance may be something less, with the determination of such at the discretion of the applicant. Therefore, until an onsite validation of observer distance is conducted by the FAA, it will remain the responsibility of the applicant to insure the safety of flight and adequate visual range coverage to mitigate any potential collisions.





3) Observers must maintain continuous visual contact with the UA.

4) Observers may be positioned in a chase aircraft. When a chase aircraft is utilized, it must maintain a reasonable proximity, and shall position itself relative to the UA in such a manner as to reduce the hazard of collision in accordance with § 91.111.

**5. COMMUNICATIONS:**

a. Raytheon shall contact Air Traffic Control prior to flight operations. Raytheon shall select and transmit transponder code 1200 unless otherwise directed by local Air Traffic Control.

b. Appropriate Air Traffic frequencies shall be monitored during flight operations.

c. All UAS crew positions must maintain two-way communications with each other during all operations. If unable to maintain two-way communication, the UA will be expeditiously returned to its base of operations while remaining within the Primary Containment Area, and conclude the flight operation.

d. Spectrum used for operation and control of the UA must be approved by the Federal Communications Commission or other appropriate government oversight agency prior to operations being conducted.

**6. FLIGHT CONDITIONS:**

a. All flight operations must be conducted during daylight hours in visual meteorological conditions (VMC), including cloud clearance minimums as specified in § 91.155. Flight operation in instrument meteorological conditions (IMC) is not permitted.

b. The UA is prohibited from aerobatic flight, that is, an intentional maneuver involving an abrupt change in the UA's attitude, an abnormal acceleration, or other flight action not necessary for normal flight (§ 91.303).

c. Flight operations must not involve carrying hazardous material or the dropping of any objects or external stores.

d. The UA and chase aircraft shall be equipped with operable strobe/anti-collision lights and shall be illuminated during operations.

e. The UA must be equipped with, and operate, an approved Mode C altitude encoding transponder during all flight operations.

f. The chase aircraft transponder must be on standby while performing chase operation flight with the UA. In the event of UA transponder failure, the chase aircraft will operate the transponder in Mode C.

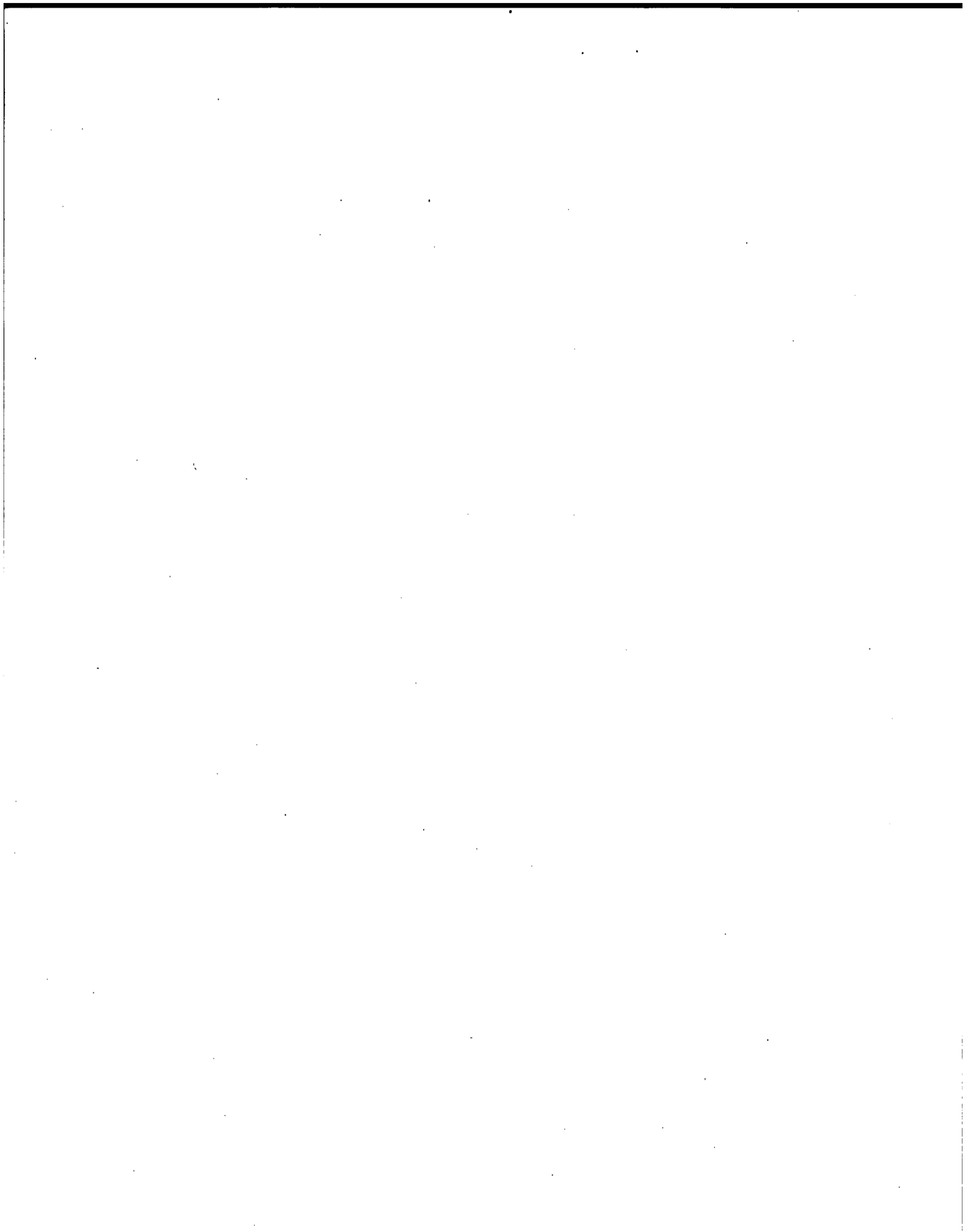

October 26, 2007

g. In the event of transponder failure on either the UA or the chase aircraft, the UA must conclude all flight operations and expeditiously return to its base of operations within the prescribed limitations of this authorization.

h. Raytheon must request the issuance of a Notice to Airman (NOTAM) through the Prescott Automated Flight Service Station at least twenty-four 24 hours prior to flight operation.

**7. FLIGHT TERMINATION & LOST LINK PROCEDURES:**

a. In accordance with Raytheon Program Letter dated September 27, 2007, flight termination must be initiated at any point that safe operation of the UA cannot be maintained.

b. In the event of lost link, the UA must provide a means of automatic recovery that ensures airborne operations are predictable and that the UA remains within the Primary Containment Area. The chase aircraft/Observer will be immediately notified of the lost link condition and the expected UA response.

**8. MAINTENANCE:**

a. The Cobra UAS must not be operated unless it is inspected and maintained in accordance with the Cobra UAS Inspection Program, dated 9/27/2006, or later FAA-approved revision. Maintenance must be recorded in the UAS maintenance records.

b. No person may operate this UAS unless within the preceding 12 calendar months it has had a condition inspection performed in accordance with, FAA-approved, Cobra UAS Inspection Program, dated 9/27/2006, and was found to be in a condition for safe operation. This inspection will be recorded in the UAS maintenance records.

c. Only those individuals authorized by Raytheon Missile Systems, who are certificated persons as authorized by 14 CFR Part 65, may perform inspections required by these operating limitations.

d. Inspections of the UAS must be recorded in the UAS maintenance records showing the following, or a similarly worded, statement: "I certify that this UAS has been inspected on [insert date] in accordance with the scope and detail of the Cobra UAS Inspection Program, dated 9/27/2006, and was found to be in a condition for safe operation." The entry will include the UAS's total time-in-service, and the name and signature of the person performing the inspection and the date the inspection was performed.

e. UAS instruments and equipment installed must be inspected and maintained in accordance with the requirements of the Cobra UAS Inspection Program, dated 9/27/2006. Any maintenance or inspection of this equipment must be recorded in the UAS maintenance records.

f. No person may operate this UAS unless the altimeter system and transponder have been tested within the preceding 24 calendar months in accordance with 14 CFR § 91.411 and § 91.413 respectively. These inspections will be recorded in the UAS maintenance records.

Page 8 of 10

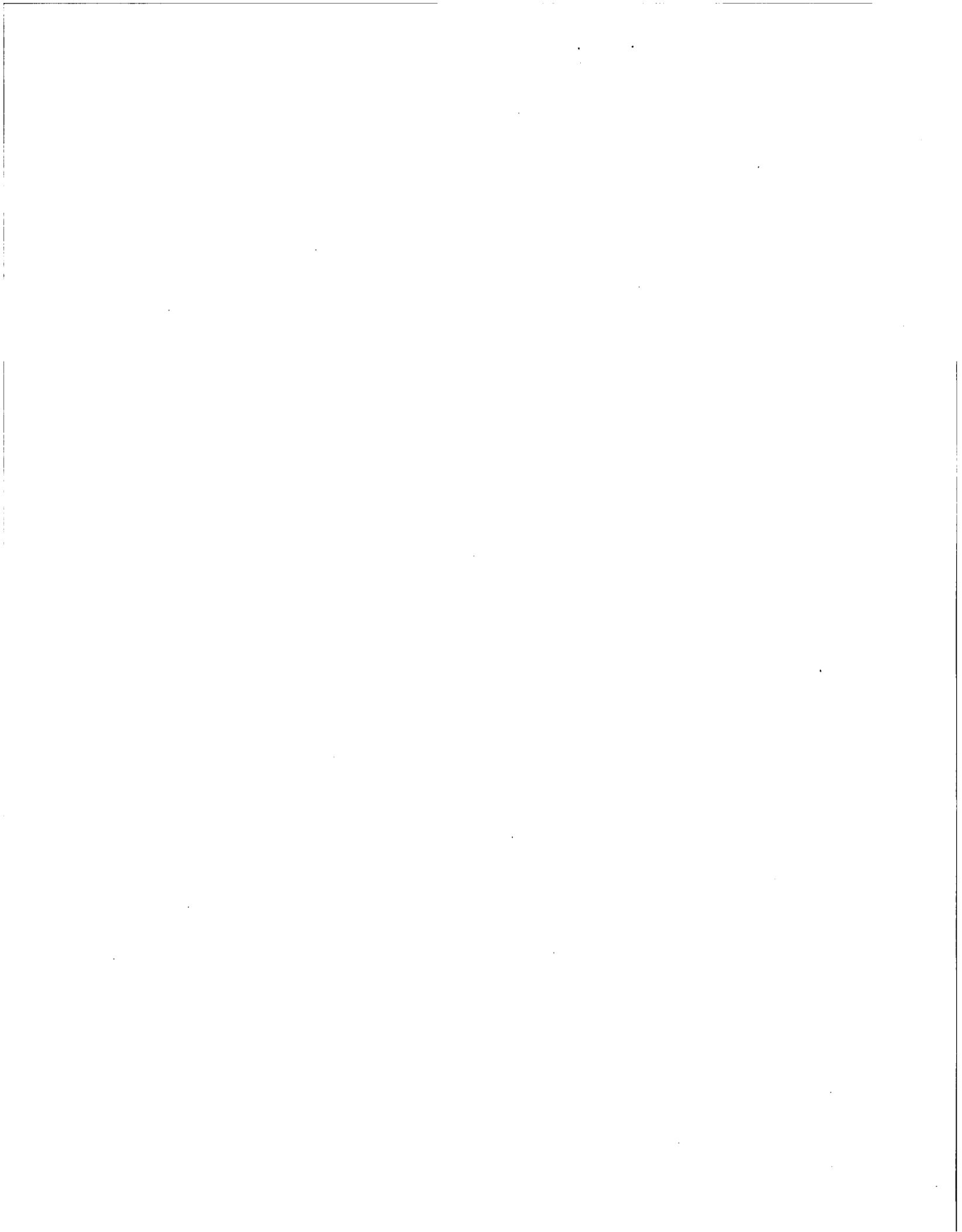

**9. EQUIPAGE:**

The Cobra Ground Control Station will be equipped with two-way communications equipment allowing for communications between the UA pilot, chase aircraft, and Air Traffic Control.

**10. REVISIONS:**

a. The Experimental Certificate, the Raytheon Missile Systems FAA-accepted Program Letter, and Operating Limitations cannot be reissued, renewed, or revised without application being made to the Phoenix Manufacturing Inspection District Office (MIDO), and coordinated with the Production and Airworthiness Division, AIR-200. AIR-200 will be responsible for headquarters internal coordination with the Aircraft Certification Service, Flight Standards Service, Air Traffic, Office of Chief Council, and Office of Rulemaking.

b. No Certificate of Waiver or Authorization may be issued in association with this Experimental Certificate unless coordinated with the Phoenix MIDO and the Production and Airworthiness Division, AIR-200.

c. The provisions and limitations annotated in this operational approval may be amended or cancelled at any time as deemed necessary by the FAA.

d. All revisions to Cobra UAS Inspection Program must be reviewed and approved by the Scottsdale Flight Standards District Office (FSDO).

**11. INFORMATION REPORTING**

Raytheon shall report the following information on a monthly basis, via email, to the Manager of the FAA UAPO, Mr. Doug Davis. Mr. Davis's email address is [Kenneth.d.Davis@faa.gov](mailto:Kenneth.d.Davis@faa.gov)

- a. Number of flights conducted under this certificate.
- b. Pilot duty time per flight.
- c. Unusual equipment malfunctions (hardware or software), if any.
- d. Deviations from ATC instructions.
- e. Unintended entry into lost link flight mode that results in a course change.

A copy of this report shall be provided to Mr. Richard Posey in the Production and Airworthiness Division, AIR-200. Mr. Posey's email address is [Richard.Posey@faa.gov](mailto:Richard.Posey@faa.gov).

**12. UA MODIFICATIONS**

a. All software and system changes will be documented as part of the normal maintenance procedures and be available for inspection. All software and system changes shall be inspected and approved per Raytheon's maintenance procedures. All software changes to the aircraft and GCS are categorized as major changes, and shall be provided in summary form at the time they are incorporated.

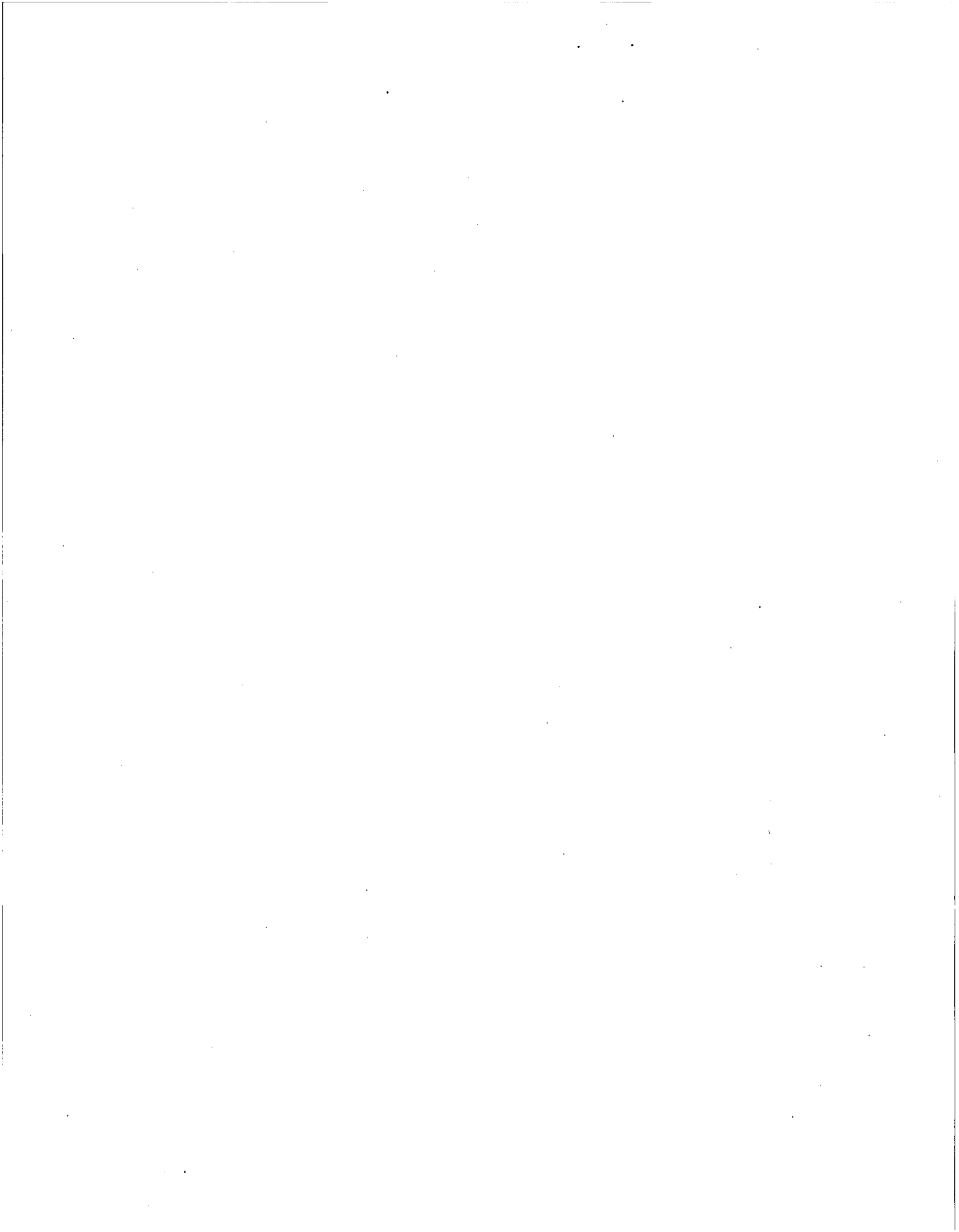

October 26, 2007

b. All major modifications, whether performed under the experimental certificate or COA, that could potentially effect the safe operation of the system, shall be documented and shall be provided to the FAA prior to operating the aircraft under this certificate. Major modifications incorporated under COA need only be provided if the aircraft is flown under COA during the effective period of the experimental certificate.

c. All information requested shall be provided to AIR-200.

End of limitations.

  
\_\_\_\_\_  
Bradley Roon  
Aviation Safety Inspector  
Phoenix Manufacturing Inspection District Office  
13951 N. Scottsdale Rd. #123  
Scottsdale, AZ 85254

Date: October 26, 2007

**The Special Airworthiness Certificate and accompanying Operating Limitations expire on October 25, 2008.**

**I certify that I have read and understand the operating limitations, and conditions, that are a part of the Special Airworthiness Certificate; FAA Form 8130-7 issued on October 26, 2007, for the purpose of Research and Development, Crew Training and/or Market Survey.**

**This Special Airworthiness Certificate is issued for the Raytheon Missile Systems, UA model "Cobra," serial number 006, registration number N606RN.**

  
\_\_\_\_\_  
Applicant:

Date: October 26, 2007

FOR

Name: Donald L. Newman

Title: Director, Unmanned Systems

Company: Raytheon Missile Systems





**Raytheon**

**Raytheon**

Program Letter (N606RN) for Unmanned Aircraft  
Systems, Experimental Airworthiness Certificate

Cobra UAS

Document ID: UNM-01-RR99818

Rev 1

09/27/2007

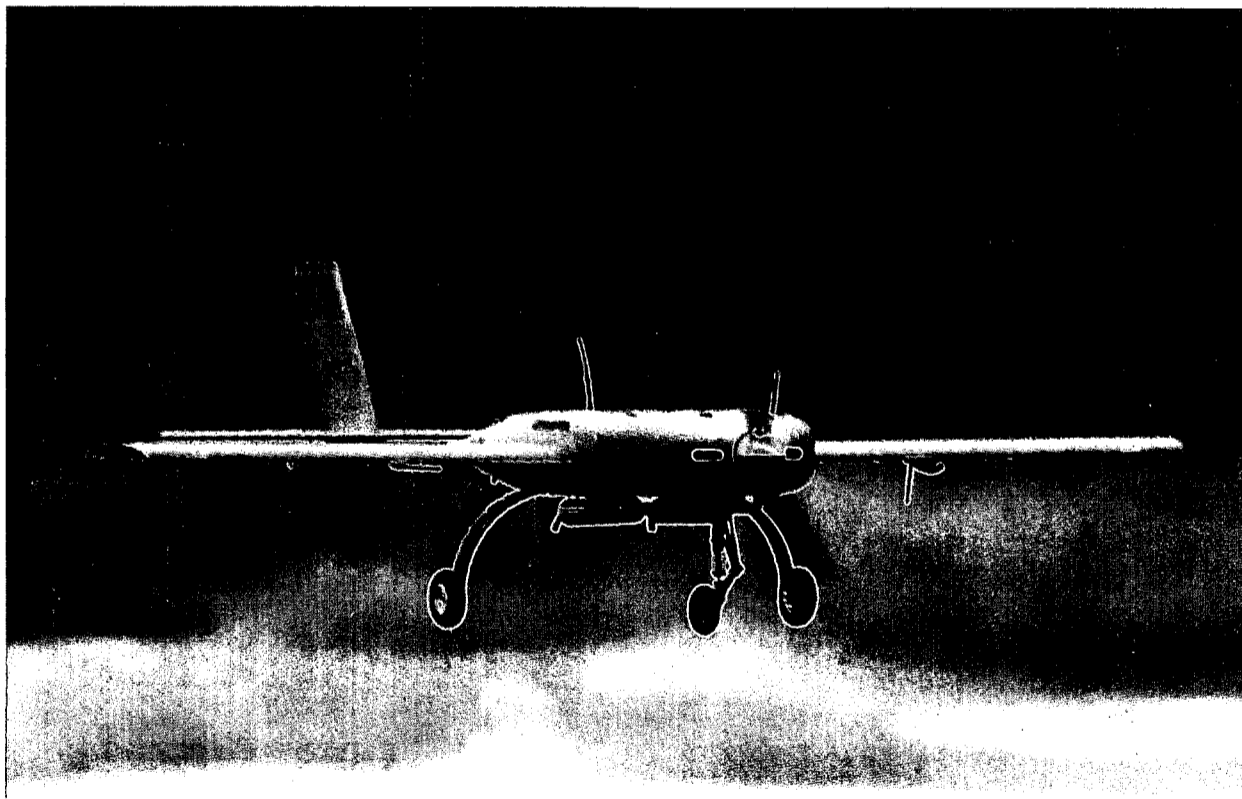

**Raytheon**

**Revision History**

<b>Revision No.</b>	<b>Description of Change</b>	<b>Date</b>	<b>Revised By</b>
Rev -	Original Document	9/09/07	MDB
Rev 1	Update Altitude, Pilot Data	9/27/07	MDB

## Table of Contents

<b>Aircraft Specifications</b>	<b>1</b>
<b>1. Define the experimental purpose(s) under which the aircraft is to be operated (14 CFR § 21.191)</b>	<b>2</b>
<b>2. Describe the purpose/scope of the experimental program for each 14 CFR § 21.191 experimental purpose sought (14 CFR § 21.193(b)(d))</b>	<b>2</b>
<b>3. Define the area(s) in which the experimental flights will be conducted</b>	<b>3</b>
<b>4. Aircraft Configuration</b>	<b>8</b>
<b>5. Inspection And Maintenance (14 CFR 91.7)</b>	<b>12</b>
<b>6. Pilot Qualification (14 CFR §§ 61.3, 61.5)</b>	<b>13</b>
<b>7. Aircraft Marking (14 CFR § 45)</b>	<b>15</b>
<b>8. ATC Transponder and Altitude Reporting System Equipment and Use (14 CFR § 91.215)</b>	<b>15</b>
<b>9. Method for See and Avoid (14 CFR § 91.113a)</b>	<b>16</b>
<b>10. Safety Risk Management</b>	<b>16</b>
<b>11. System Configuration</b>	<b>17</b>
<b>12. System Safety – Flight Termination and Lost Link</b>	<b>17</b>
<b>13. Command and Control</b>	<b>19</b>
<b>14. Control Stations</b>	<b>20</b>
<b>15. Control Frequencies</b>	<b>21</b>
<b>Appendix A - Cobra Drawings and Photographs</b>	<b>23</b>
<b>Appendix B - Cloud Cap Piccolo II Users Guide</b>	<b>26</b>
<b>Appendix C - Raytheon UAS Flight Manual</b>	<b>27</b>
<b>Appendix D - Cobra Weight and Balance</b>	<b>27</b>
<b>Appendix E - Minimum Equipment List</b>	<b>28</b>
<b>Appendix F - System Configuration Diagram</b>	<b>32</b>
<b>Appendix G - FAA UAS Safety Checklist</b>	<b>35</b>
<b>Appendix H – Acronym List</b>	<b>36</b>

## Table of Figures

<b>Figure: 1 Cobra UAS</b>	<b>2</b>
<b>Figure: 2 UVI Airfield</b>	<b>4</b>
<b>Figure: 3 Containment Area</b>	<b>6</b>
<b>Figure: 4 Cobra 3 View Drawing</b>	<b>8</b>
<b>Figure: 5 MVCS CUCS</b>	<b>11</b>
<b>Figure: 6 Piccolo Autopilot Limits</b>	<b>18</b>

# Raytheon

**Aircraft Specifications**

**Registered Owner Name:**  
Raytheon Company

**Registered Owner Address:**  
Raytheon Missile Systems  
Bldg M09, M/S 5  
P.O. Box 11337  
Tucson, AZ 85734-1337

**Aircraft Description:**

The aircraft is an unmanned, composite, mid-wing monoplane with standard tail surfaces and a tractor engine. The vertical and horizontal stabilizers are attached to a composite tail boom. The control surfaces consist of full span flaperons, elevator and rudder. The landing gear is tricycle type with a steerable nosewheel, and the main landing gear is equipped with pneumatic brakes. The engine is a 16 hp, air-cooled, 2-cycle, 2 cylinder, opposed, and carbureted powerplant with an electronic ignition system, using gasoline with a 100:1 2-cycle oil mix. Primary electrical power comes from a 500 watt generator with a 180 watt regulator. A Lithium Polymer rechargeable battery provides backup electrical power for 1 hour in the case of main power source failure.

As a prototype airframe, Raytheon expects that there will be slight design changes based on the data collected from the initial test flights.

**Aircraft Registration:**

This will be an Experimental Aircraft Registration.

Unless otherwise specified in the certificate, the aircraft will be marked on the aft fuselage surface using the N12345 format. 3" lettering will be used due to the small size of the aircraft. The word "Experimental" will be displayed on the fuselage over the wing in 1/2" letters.

**Aircraft Builder:**  
Raytheon Missile Systems

**Year Manufactured:**  
2006

**Aircraft Serial Number:**  
Serial Number 006  
(Update serial number for each application)

**Aircraft Registration Number:**  
N606RN

**Aircraft Model Designation:**  
Cobra

**Engine Model:**  
Desert Aircraft DA-150  
[http://www.desertaircraft.com/engines\\_detail.php?Page=DA-150](http://www.desertaircraft.com/engines_detail.php?Page=DA-150)

**Fuel:**  
87-91 Octane Gasoline  
OR  
100 Octane Aviation Fuel

**Oil:**  
Saber™ Professional Synthetic 100:1 Pre-Mix 2-Cycle Oil (ATP)  
<http://www.amsoil.com/storefront/atp.aspx>

**Propeller Model:**  
Mejzlik 28 x 12 -3b; 28 x 12 W-3b; 30 x 12  
<http://mejzlikmodellbau.inshop.cz>

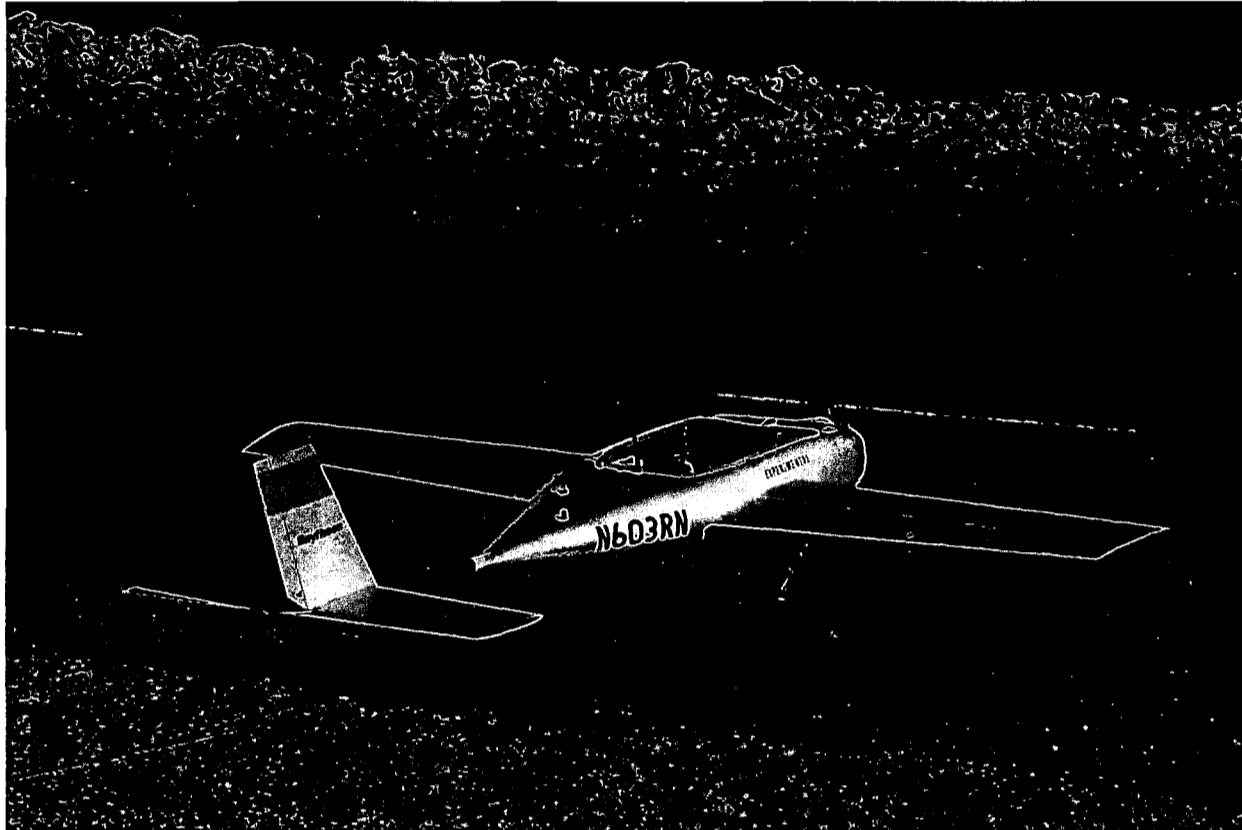

Figure: 1 Cobra UAS

**1. Define the experimental purpose(s) under which the aircraft is to be operated (14 CFR § 21.191)**

*Research and development.* Testing new unmanned aircraft design concepts, avionics and ground equipment, Command and Control Systems, installations, operating techniques, and new uses for unmanned aircraft.

*Crew training.* Training of the Raytheon Company flight crews.

*Market surveys.* Use of UAS for purposes of conducting market surveys, sales demonstrations, and customer crew training only as provided in §21.195.

**2. Describe the purpose/scope of the experimental program for each 14 CFR § 21.191 experimental purpose sought (14 CFR § 21.193(b)(d))**

*Research and development* – This unmanned aircraft will be used as a test bed for data links, sensors, processors, autopilots, “sense and avoid” and other electronics/avionics as required to meet the Raytheon Company business goals.

*Crew training* – Flights will be conducted by qualified Raytheon UAS pilots. Aircraft checkout and regular proficiency training will be conducted to meet the Raytheon

# Raytheon

Company flight testing requirements. Upon customer request, flight training of a customer pilot will occur.

A training program will be submitted as a separate document.

*Market surveys* – This aircraft will be used to demonstrate the concepts, electronics and avionics listed above to various public customers. The demonstration of the Cobra UAS will only be conducted at the site approved under the experimental airworthiness certificate.

### **3. Define the area(s) in which the experimental flights will be conducted**

- Describe the areas over which the flights are to be conducted and address of base operation (14 CFR § 21.193(d)(3)).

Raytheon leases a new facility built specifically by Unmanned Vehicles International (UVI) Inc. (<http://www.uviinc.com/>) to operate UAS near Sierra Vista, AZ.

Unmanned Vehicles International, Inc  
633 Wilcox Drive  
Sierra Vista, Arizona 85635  
520-458-4212

Raytheon has been using this facility for local UAS operations since April 2005, and has accumulated 119 hours from 200 flights using the Manta, Silver Fox, and Cobra UAS.

# Raytheon

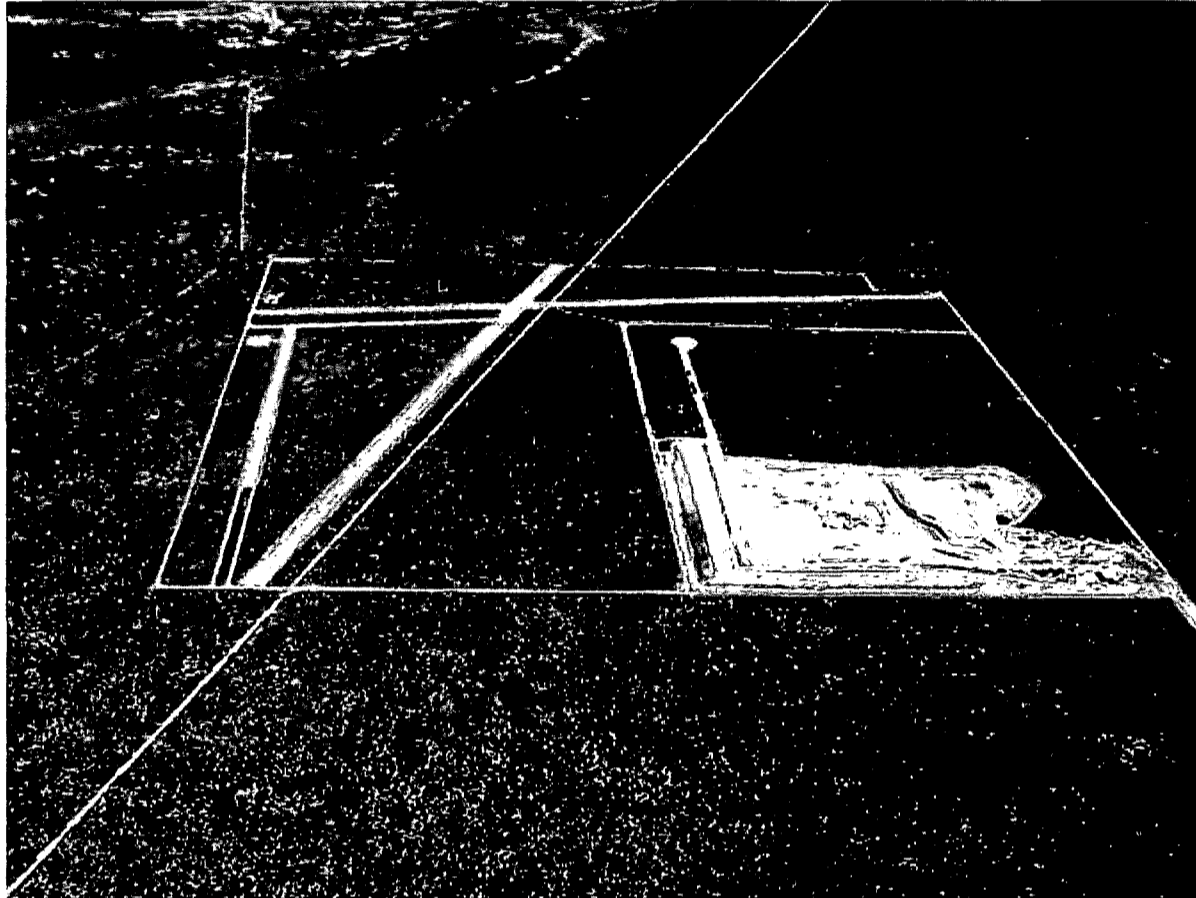

Figure: 2 UVI Airfield

UVI UAS airfield looking north, located next to the Cochise County landfill.

Phoenix Sectional

FHU 004/08.5, 4225' Elevation

N 31° 43' 30", W 110° 17' 47"

The UVI site is shown in Figure 2 and was specifically located to have easy access to the R-2303 restricted airspace. Not having regular access to the restricted airspace, Raytheon will operate below the 8000' MSL lower limit of R-2303B to remain outside of restricted airspace unless prior coordination has been obtained. The pattern altitude is 700' AGL. When not landing, Raytheon would operate at 2000' AGL and below, normally remaining between 1500' and 2000' AGL. As a civil user not on a DoD contract, Raytheon does not have priority access to the R-2303 airspace. Through UVI Inc, Raytheon has coordinated with the Libby Field Airspace Manager, El Paso Gas (pipeline patrol) and the Border Patrol, and has directly coordinated with Prescott Flight Service Station for NOTAMs. NOTAMs will be filed as directed by the FAA.

The Four Pillars (AZ21) airfield indicated in red on the map shown in Figure 3 is currently abandoned.

## Raytheon

The UVI site is located on state property and is operated on a state lease for the purpose of operating UAS. The State has approved the lease to UVI Inc for UAS operations only. From Highway 82 to the south to I-10 on the north, the land is nearly uninhabited. The only ground traffic in the proposed operating area is along Highway 80 from Tombstone to Benson.

The Raytheon local operating area is a 1 mile radius from UVI and the aircraft are kept north of Highway 82 and east of Highway 90. When flight operations will remain within 1 NM and the Ground Observer will be able to maintain visual contact, and a chase plane will not be used.

In Figure 3, the larger area outlined with a hashed red line is the proposed Raytheon UAS containment area. This will be used for developmental testing and demonstration from the surface to 2000' AGL (6200' MSL average). All of Raytheon's UAS flight operations will be within radio line of sight of the Ground Control Station. Victor Airway 66 crosses the proposed operating area and has a Minimum Reception Altitude (MRA) of 9500' MSL (4500' AGL). VR 259 from points D to E, and VR 260 from points D to E, also cross this area, and Raytheon will contact Flight Service to see if they are active prior to crossing. For flights beyond visual range of the Ground Observer, a chase plane will be used. The chase plane and UAS will have active transponders when within the lateral limits of the VR routes.

The class E airspace overlaying the proposed operating area is used for instrument approaches into Libby Army Airfield (KFHU). The TOMBS intersection is the missed approach holding point at 9500' MSL, and the minimum vectoring altitude is 6500' MSL for IFR traffic. Raytheon reports operations to Libby Approach and monitors the approach control frequency during flight. By agreement with Libby Radar, Raytheon squawks 1202 mode C to differentiate from other VFR traffic.

Ninety Percent of the proposed operating area is uninhabited state land. The cutouts at the corners of the proposed op area are designed to keep Raytheon UAS away from the small communities of Whetstone to the SW, St David to the north, and Tombstone to the SE. The eastern border is the edge of the Tombstone MOA. State highway 90 borders the western edge, state highway 82 the southern edge. The only trafficable road inside the op area is state highway 80, a two lane blacktop between Benson and Tombstone. The San Pedro river valley traverses the area south to north, and is a designated wildlife area. All flight operations over the wildlife area will be 2000' AGL or above.



- Identify all proposed flight areas using latitude and longitude on aeronautical maps.

The following grid coordinates define the Raytheon Op Area:

1. N 31° 44' 00.00" W 110° 20' 30.00"
2. N 31° 52' 00.00" W 110° 20' 00.00"
3. N 31° 52' 00.00" W 110° 11' 00.00"
4. N 31° 56' 30.00" W 110° 11' 00.00"
5. N 31° 58' 10.00" W 110° 03' 00.00"
6. N 31° 50' 30.00" W 110° 03' 00.00"
7. N 31° 50' 30.00" W 110° 00' 00.00"
8. N 31° 45' 00.00" W 110° 00' 00.00"
9. N 31° 45' 00.00" W 110° 11' 00.00"
10. N 31° 43' 14.00" W 110° 14' 00.00"
11. N 31° 42' 00.00" W 110° 19' 30.00"
12. N 31° 44' 00.00" W 110° 19' 30.00"
13. Return to 1



Figure: 3 Containment Area

# Raytheon

- Include information on airspeed, altitude, number of flight hours, number of flights and program duration for each test flight area.

Airspeed: 35-100 KIAS

Altitude: 2000 AGL and below

Winds: 20 KTS headwind, 10 KTS crosswind

Flight Hours: 300 flight hours per year

2-3 flight days per week during the workweek. Weekend flying will occur only once per quarter.

Duration: 1 year for this application, with renewal annually.

- What class of airspace will be used?

FAA Class E and G.

- Will minimum fuel requirements of 14 CFR § 91.151 be met?

Yes, a fuel reserve minimum of 30 minutes for day flying will be maintained.

- Will flight-testing include payload testing?

Yes. Various Electro Optic, passive and RF sensors will be tested. Frequency management will be coordinated with the FAA, FCC Western Region and Fort Huachuca frequency managers.

- What considerations need to be taken with regard to Payloads?

Considerations include size, weight, power requirements, EMI/RFI, drag, data communications and additional crew.

Size and weight of the payload will affect the aircraft weight and balance and maximum gross weight. The power draw on the onboard electrical system and backup batteries must also be considered. EMI/RFI might affect the aircraft as well as the payload. If the payload is external or has external components such as antennae, the drag increase must be evaluated. If the payload requires additional data communications, the effect on the available bandwidth and data priority as compared to command and control data will be evaluated. The addition of a payload will affect the workload of the crew depending on its complexity. The workload will be evaluated and an additional crew member added if required to operate the sensor. The addition of flight crewmembers or additional training will be considered when required for new payload operations.

- Will the aircraft perform any aerobatic maneuvers?

No

- Flight Conditions (e.g., VFR, IFR, VMC, etc.)

Day VFR only. All testing, training and demonstration will be conducted in Day VFR conditions.

## 4. Aircraft Configuration

- Attach three-view drawings or three-view dimensioned photographs of the aircraft (14 CFR § 21.193(b) (4)). (Appendix A)

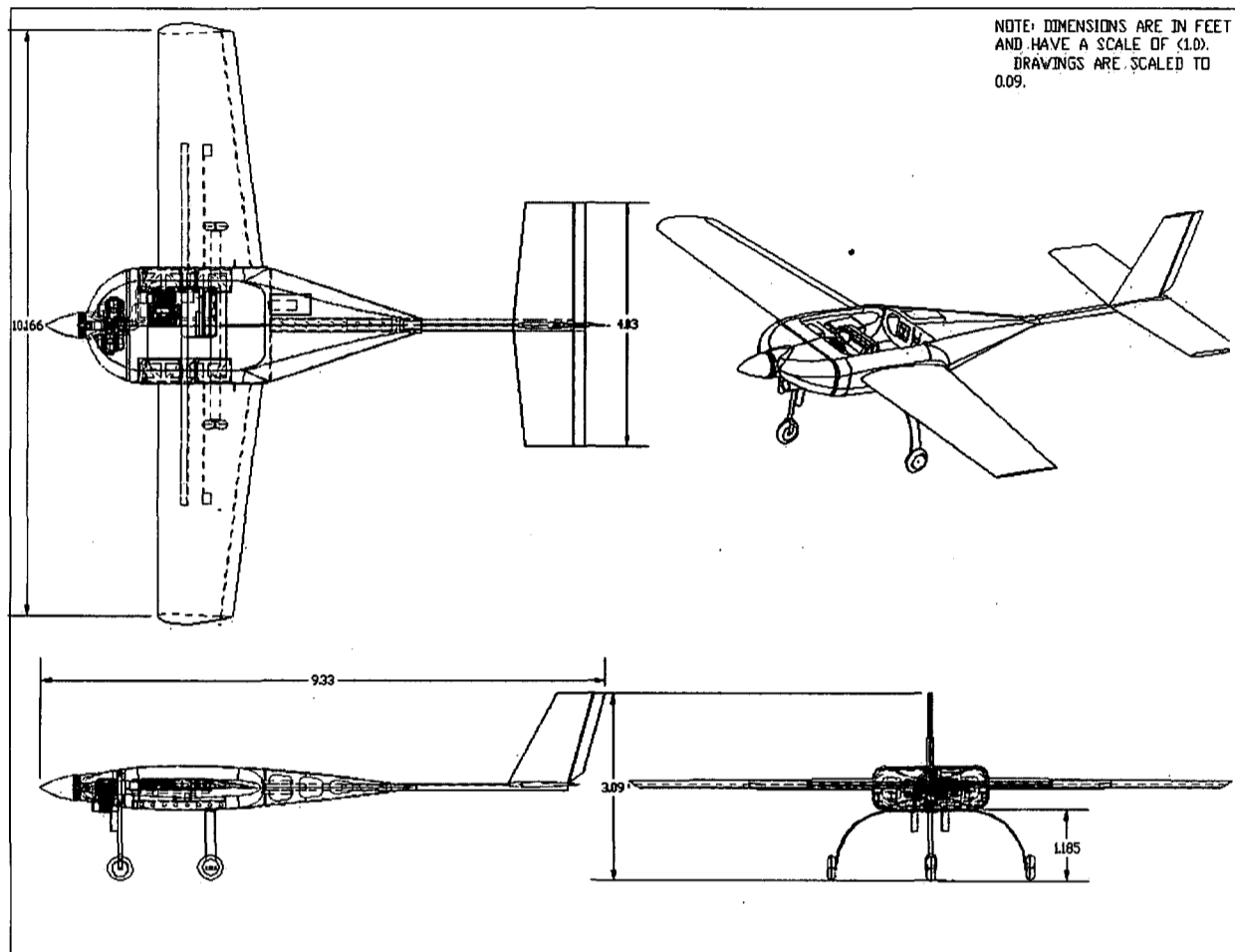

Figure: 4 Cobra 3 View Drawing

- Describe Unmanned Aircraft System configuration including ground control station.
  - Cobra UAS
    - Cloud Cap Piccolo II Autopilot (<http://www.cloudcaptech.com/>)  
See Appendix B – Piccolo Systems Users Guide  
The Piccolo II is a MEMS based autopilot that allows for manual, stability augmentation, and autonomous control of the UAS. The air data system, GPS, and Microhard datalink are built into a compact, low weight, avionics package. A Honeywell magnetometer provides magnetic heading information to the autopilot.
    - DGPS (<http://www.novatel.com/products/flexpak.htm>)

# Raytheon

A Novatel FlexPak-G2L DGPS provides centimeter level accuracy for Autonomous takeoff and landing operations.

- Transponder

Microair 2000, mode 3a/c with air data provided by an altitude encoder or the Piccolo II flight control system.

The transponder will be required for all flights.

- Lights

A white strobe light will be attached to the upper fuselage as an anti-collision light for all flights.

- Video Transmitter

An independent COTS ¼ to 3 watt video transmitter at 2.4 GHz will be used for transmission of the video signal.

- Power

Primary electrical power comes from a 500 watt generator with a 180 watt regulator. A Lithium Polymer rechargeable battery provides backup electrical power for 1 hour in the case of main power source failure. The battery is charged in flight.

The system voltage is indicated to the pilot as well as a visual and audio alert if the high or low voltage range is exceeded. While on Generator power (14.8 volts) the voltage is green. If the generator fails, the battery (15.8 volts) comes online and the alert sounds. Once the battery is below 14.8 volts the alert will stop until the low voltage value is exceeded.

- Datalink

- Microhard MHX UHF Datalink

The Piccolo autopilot has an integrated MHX-910 frequency hopping radio from Microhard Systems Inc. The MHX radio is a 900MHz ISM band radio with good receive sensitivity and a maximum 1 Watt output power. The wireless link formed between radios extends from all the aircraft to the ground station. Traditional wireless links were made of a single frequency, and multiple networks could be constructed by using multiple frequencies. With a frequency hopping radio the concept of networks defined by frequencies is replaced with networks defined by hopping patterns. Hence it is possible to have a network of radios using one hopping pattern while another network of nearby radios uses a separate hopping pattern. In each case a single ground station coordinates the communications for each network.

The Microhard radio has a 25 NM range and is used as the Primary control link when installed alone or as the secondary link and flight termination system if a developmental datalink is installed.

# Raytheon

- Raytheon MicroLight UHF Datalink

The MicroLight radio is based on the Raytheon Enhanced Position Location Reporting System (EPLRS) technology. This is a software programmable digital datalink operating from 420-450 MHz. This radio is networkable, allowing the radio to act as a node in a network. This radio has a 100 NM range. The range is variable with the selected mode of operation.

The MicroLight UHF Datalink is developmental and can be used for C2 and low rate video. This radio will be evaluated for Joint Tactical Radio System (JTRS) waveforms, and its usability within a net-centric UAS.

- Other developmental datalinks (See Proprietary Payload Addendum)

For all datalink testing, the original MicroHard link provided with the Piccolo II autopilot will be maintained as a secondary safety backup and flight termination system.

- Ground Control Station

- Raytheon Multi-Vehicle Control System (MVCS)

The MVCS is a derivative of the US Navy Tactical Control System and can be used to control different types of UAS as long as a STANAG compliant Vehicle Specific Module (VSM) has been created for that aircraft. STANAG 4586 is a NATO standard for interoperability between diverse UAS. The MVCS is networkable allowing multiple pilot consoles to be connected together and to share data. MVCS is also designed to be hosted on the Digital Common Ground Station (DCGS) developed by the US Air Force.

- STANAG 4586 Vehicle Specific Module (VSM)

The VSM is the interface or translator between the aircraft and the ground control station. It is software, and can be hosted on an airborne processor in the aircraft or the computer connected to the Ground Control Station. The VSM used by the Cobra is the same as that used on the Manta and Silver Fox UAS. The VSM interface for these aircraft was created to communicate with the Piccolo autopilot.

- STANAG 4586 Common UAV Control Station (CUCS)

The CUCS is the operator interface to the system controls. It provides the displays of information to the Pilot (Figure 5). The displays are configurable and can be considered a virtual Multi-Function Display (MFD). The displays include the Primary Flight Display (PFD), a moving map or situational awareness display, Warnings and Cautions, and various data displays for the aircraft telemetry. This system allows satellite imagery to be used as a

moving map display. When more than one UAS telemetry stream is detected on the network, all UAS positions are shown on the map with an ID and altitude tag.

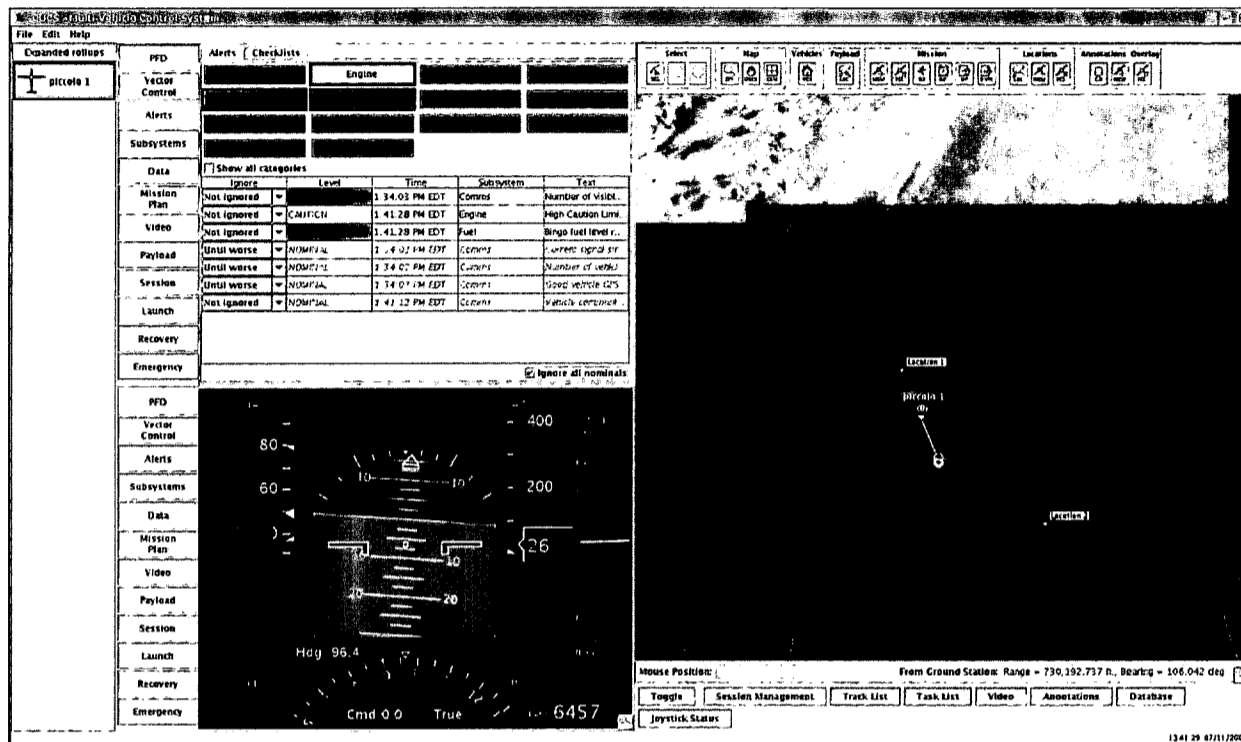

Figure: 5 MVCS CUCS

- Cloud Cap Piccolo Operator Interface
  - See Appendix B – Piccolo Systems Users Guide. The Piccolo Operators Interface can be used as a stand alone or in concert with the MVCS. Often it is used for preflight and launch/recovery while the MVCS is used for cruise flight. This allows multiple pilots to manage multiple aircraft from a series of networked pilot consoles.
- Payloads
  - See Proprietary Addendum
- Include a description of aircraft/system performance characteristics:
  - Wing span: 10.166 FT.
  - Length: 9.33 FT.
  - Power Plant: Desert Aircraft, DA-150, 16 HP, Air Cooled, Two-Cylinder Opposed, 2 Stroke Gasoline Engine
  - Max Gross Take Off Weight: 105 LBS
  - Fuel capacity: 4.0 GAL, 87-100 Octane with 100:1 oil mix

# Raytheon

- Payload Capacity: 30.0 LBS
- Max altitude: 15,000 FT. MSL
- Endurance: 4 hours
- Max airspeed: 95 KTS
- Wind Limitations: 20 KTS headwind 10 KTS crosswind
- Control/data frequencies: 420-450 MHz Primary, 902-928 MHz Secondary
- Guidance and navigation control: Cloud Cap Technologies Piccolo II Autopilot
- Flight termination frequencies, if any: 902-928 MHz. Raytheon uses the Microhard datalink as a flight termination device when developmental datalink is installed.

## 5. Inspection And Maintenance (14 CFR 91.7)

- Describe the inspection and maintenance program that will be used to maintain the aircraft and related systems (includes ground stations and/or other support systems).

See Raytheon Cobra UAS Inspection Plan

An aircraft logbook will be maintained on each aircraft, and a separate logbook for the ground control station. An engine log will be maintained for each engine as well.

The engines will be overhauled at 250 hours.

Discrepancies and maintenance actions will be noted in an electronic format used by Raytheon Integration and Test, and repairs will be made by Flight Test Team engineers. Preflight and postflight inspections will be conducted for all flights, as well as periodic inspections during integration and development.

An annual inspection will be conducted in accordance with the Cobra Inspection Plan.

Raytheon maintains a Test Readiness Review (TRR) process, where any changes to the configuration of the system must be approved by a board of senior engineers prior to testing. The status of all aircraft and any outstanding maintenance actions are reviewed at this time. Flight safety is the primary concern of the TRR.

- Provide copy of flight manual, if applicable, current weight and balance report, equipment list.

The Raytheon Cobra UAS Operations and Weight and Balance are included as appendix C and D.

The small size of the aircraft allows it to be weighed, and Center of Gravity (CG) calculations done prior to each flight. The data is collected and has been used to create a basic weight and balance calculator in a spreadsheet. The weight and cg envelope shows the limits of data collected to date. CG expansion tests will be conducted during aircraft performance testing.

A minimum equipment list is shown in Appendix E.

## 6. Pilot Qualification (14 CFR §§ 61.3, 61.5)

- Describe the qualifications for each pilot.

See the Raytheon Cobra UAS Training Plan.

The Cobra requires a crew of 1 pilot. If required a Supplemental Pilot (SP) can assist the Pilot. The UAS pilot will be an FAA certified pilot for all flights, and shall be designated the Pilot in Command (PIC).

Pilot –FAA certified Private Pilot Airplane, physically and medically capable of completing all required tasks, and complete a UAS Practical Flight Test administered by the Raytheon Chief UAS Pilot or his designee. The Pilot must hold an FAA 3d class medical certificate.

Supplemental (External) Pilot (SP) – 3 Years previous RC Model experience with a similar aircraft or FAA certified Private Pilot Airplane, physically and medically capable of completing all required tasks, and complete a UAS Practical Flight Test administered by the Raytheon Chief UAS Pilot or his designee. The Supplemental Pilot must hold an FAA 3d class medical certificate and complete the FAA Private Pilot written test.

Observer - physically and medically capable of completing all required tasks, and approved by the Raytheon Chief UAS Pilot or his designee. The Observer must hold an FAA 3d class medical certificate and complete the FAA Private Pilot Written test.

The Pilot flies using the pilot computer console by reference to the Multi-Function Display, and other telemetry data, using the autopilot functions or the manual pilot console. The Pilot will take direction from Air Traffic Control or Observer to avoid other aircraft.

The PIC is responsible for the conduct of the flight, coordination, weather and preflight planning.

The Supplemental Pilot flies by visual reference using the manual pilot console. When in control, the SP will maneuver as required to avoid other aircraft. The SP cannot act as Observer when in control of the aircraft.

An observer will be assigned for all flights. He can be on the ground or in the chase aircraft.

An example of the Raytheon pilot qualifications are listed below:

### Chief UAS Pilot

Certified Flight Instructor-Airplane, Commercial Instrument ASEL, AMEL, Commercial Glider, Commercial Helicopter, Airframe and Powerplant Mechanic, Chase Plane Pilot UAS Pilot, UAS Test Pilot, UAS Instructor, Sensor Operator, Observer, 1200+ UAS hours, Gnat 750, IGnat, Pioneer, Sentry STM-5A/B, Exdrone, Pointer, Manta, Silver Fox, Cobra



# Raytheon

## Supplemental Pilot

RC Pilot, RC Test Pilot, UAS Pilot, UAS Test Pilot, UAS Instructor, Observer, 230+ UAS hours, Manta, Silver Fox, Micro Fox, MAV, SUAV, LUAV, Cobra

- Pilots must be qualified and/or certificated in the appropriate category of aircraft, i.e., rotorcraft, powered lift, airplane, etc.
- Describe internal training program to qualify pilots.

Pilots are chosen for their experience with UAS, manned or RC aviation. Manned aircraft pilots are trained to be UAS Pilots, and RC pilots are trained to be Supplemental Pilots (SP).

All pilots are given detailed information on the UAS system, including aircraft performance, limitations, flight controls, communications, autopilot functions, datalink operation, local procedures, crew coordination and emergency procedures.

In addition, specific training will be given in the following areas as it pertains to UAS operations:

- Applicable Federal Aviation Regulations
- NTSB Accident reporting requirements
- Aeronautical Information Manual and FAA advisory circulars
- Aeronautical charts for navigation
- Radio communication procedures
- Weather, windshear avoidance, and aeronautical weather reports and forecasts
- Aircraft collision avoidance, and wake turbulence;
- Density altitude effects
- Weight and balance computations
- Principles of aerodynamics, powerplants, and aircraft systems
- Stall awareness, spin entry, spins, and spin recovery techniques
- Aeronautical decision making and judgment
- Preflight action that includes how to obtain information on runway lengths at airports of intended use, data on takeoff and landing distances, weather reports and forecasts, and fuel requirements.
- Preflight preparation, preflight procedures, airport operations, takeoffs, landings, and go-arounds, navigation, slow flight and stalls, emergency operations, and postflight procedures.

The Pilot is given additional training on the software operator interface, and mission commander duties and is required to be familiar with SP pilot duties. A simulator is used prior to Pilot flight training. Pilots will demonstrate this knowledge to the correlation level prior to Raytheon certification.

# Raytheon

The SP is also trained to take manual control as required to avoid other aircraft and is required to be familiar with pilot duties.

- Describe the qualifications and training of observers.

Observers are trained in scanning techniques, and to verbally communicate the location of other aircraft. Observers will have instruction on 14 CFR § 91.111 and 91.113.

## 7. Aircraft Marking (14 CFR § 45)

- All Cobra UAS are required to be registered and identified with the registration number. (45.29(f))
- Unless otherwise specified in the certificate, the aircraft will be marked on the aft fuselage surface using the N12345 format. 3" lettering will be used due to the small size of the aircraft. The word "Experimental" will be displayed on the fuselage over the wing in ½" letters.

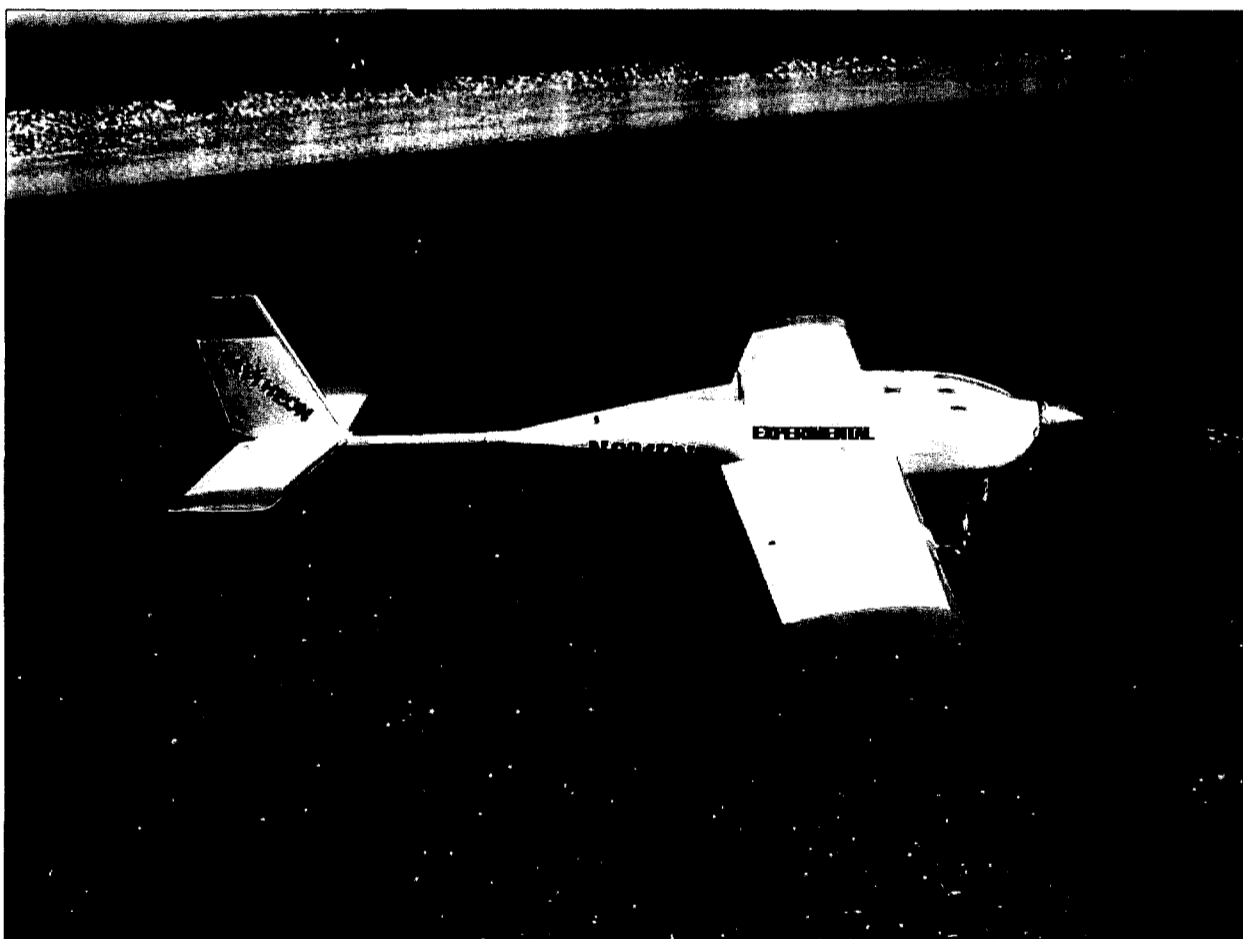

## 8. ATC Transponder and Altitude Reporting System Equipment and Use (14 CFR § 91.215)

- Describe the aircraft altitude reporting system.

# Raytheon

The aircraft has a miniature air data system built into the autopilot. Altitude calibration is done daily via the GCS operator interface by setting the field elevation and local barometric pressure. The local barometric pressure is received from the ATIS broadcast from Libby Army Airfield.

An onboard Transponder with altitude encoder is installed. See Appendix E MEL. An independent Altitude Encoder will provide the pressure altitude for mode C. During integration testing, the mode 3 code will be manually set to 1200 or as assigned before launch. When the software interface has been developed, the transponder will be accessible to the pilot for mode 3 code changes, ident, and Off/Standby/On/Alt functions.

## 9. Method for See and Avoid (14 CFR § 91.113a)

- In what manner, or by what means, will the requirement to “see and avoid” other aircraft be met?

For local flights a ground observer will be used to see other aircraft.

Raytheon will have a chase plane for all flights outside visual line of sight. The chase plane will be manned by a pilot and observer. Raytheon will comply with the FAA definition of observer. The roll of the observer will be to look for and call out all other air traffic. The observer will not have FTS capability. Voice communications between the chase aircraft and the UAS pilot at the Ground Control Station will be by VHF radio. In the event voice communication is broken with the chase aircraft for more than 1 minute, the UAS will be returned for landing. At any time during the flight, the UAS pilot will be able to take control and maneuver as required to avoid other aircraft as directed by the chase plane observer. In an emergency the UAS pilot can execute the terminate flight function built into the autopilot. The chase aircraft will be squawking 1200 or as assigned. The pilots of the chase aircraft and UAS will have a face to face formation brief prior to all chase flights.

- What performance will the chase plane have?

The chase aircraft will have the performance required to keep the UAS in sight at all expected airspeeds and altitudes.

## 10. Safety Risk Management

- An applicant must provide a hazard analysis that identifies and analyzes the hazards of UAS operations that are described in the program letter.

See Appendix G

- Additional information is available by contacting the FAA representative.

## 11. System Configuration

- Provide description of aircraft system configuration and all on-board and ground-based equipment.

Provided in paragraph 4, Aircraft Configuration. See Appendix F for a system diagram.

## 12. System Safety – Flight Termination and Lost Link

- What is the expectation of aircraft “Flight” if fuel is starved?

The system will provide the pilot with a visual and aural warning that the engine has failed. The aircraft will glide at the current commanded airspeed and continue to navigate to the next waypoint on the active flight plan. The backup battery system will continue to power the aircraft and all electrical systems in excess of one hour at maximum load. If altitude permits, the pilot will navigate the aircraft to a landing point of his choosing, and if video is available, he will use video to avoid obstructions on the ground.

- Describe/explain aircraft lost link and emergency recovery procedures.

- Command and Control

The Piccolo autopilot is programmed to fly to a “lost link” waypoint that is a point on a lost link flight plan. The lost link point can be changed during the course of the flight to follow the operational flight plan. The Pilot plans the lost link route to return to base at a safe altitude, and on a predictable flight path. The final 4 points on the lost link plan are looped to create a loiter pattern. If desired, the pilot can plan the lost link route to land the aircraft autonomously. The lost link timeout is set by the pilot during preflight. Raytheon procedure is to set the timeout to 10 seconds. During launch and recovery, the lost link point is set to a point on the departure end of the runway to prevent a turn close to the ground and in proximity to the GCS in case of lost link during the takeoff roll or during final approach.

A backup Piccolo GCS/datalink is available, and will be used in the event of GCS failure.

- Flight Termination

- In the event that datalink is lost and/or GPS becomes unusable, the Piccolo II autopilot can be set to automatically activate the flight termination function. The function will kill the engine, forcing a landing, or, if desired, can cause an aerodynamic termination. The details can be found in Appendix B, Piccolo II Users Guide. Raytheon sets this option to kill the engine if GPS fails. Figure 6 shows the settings available to the pilot for automatic flight termination. In Piccolo terminology, the “Deadman Line” is the ignition system.

Manual termination is done by killing the engine or selecting manual control and overriding the autopilot.

When the developmental datalink is installed, the Piccolo Microhard datalink can be used to sever the developmental link from the autopilot.

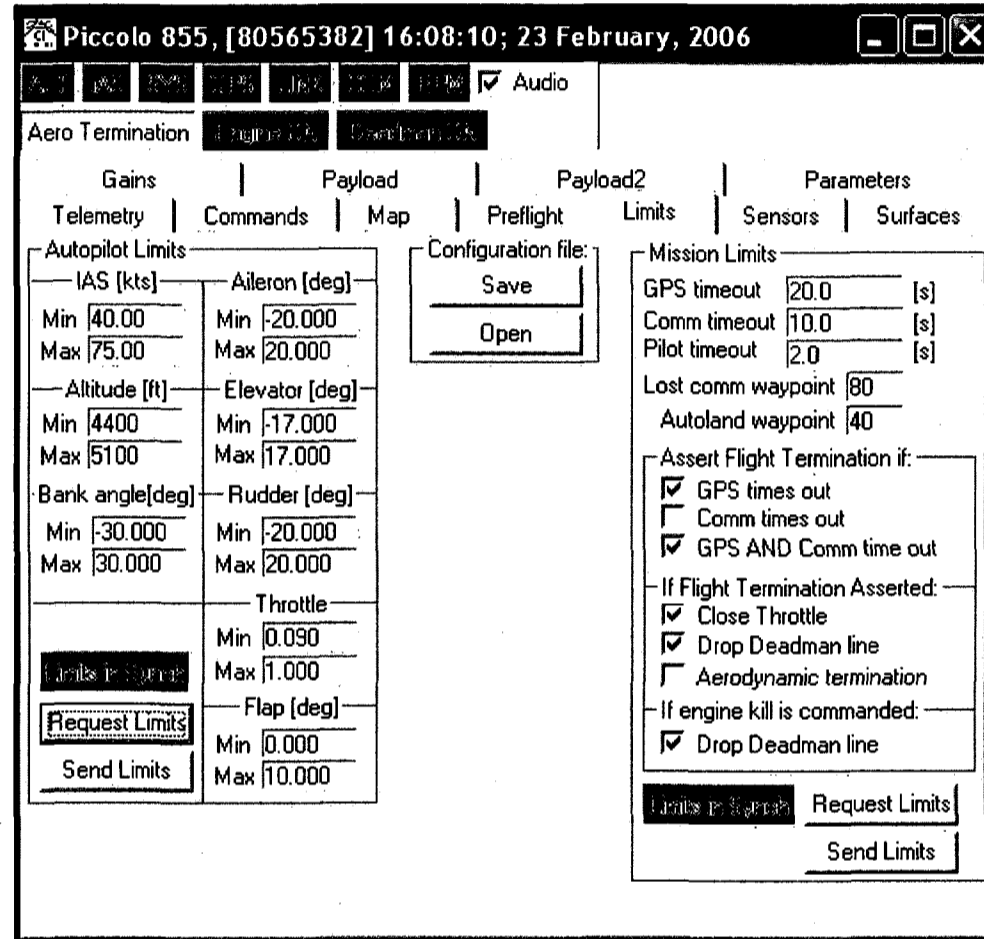

Figure: 6 Piccolo Autopilot Limits

o Loss of GPS

In the event that the GPS signal is lost, the autopilot will navigate by Dead Reckoning (DR) with the magnetometer installed, or execute Flight Termination as selected by the pilot. Visual and aural warnings are given to the pilot if navigation accuracy cannot be maintained. The pilot has the option of visually navigating to landing.

## 13. Command and Control

- Provide a description of the system and/or procedures for command and control of the UAS.

See Appendix C, Raytheon UAS Flight Manual

Cobra is manually taxied into takeoff position by the pilot or SP. The UA is launched by the pilot using Auto Takeoff. The pilot activates the takeoff by pressing the Launch button. The throttle is added slowly, and increases as forward speed is detected. The UA steers to centerline until rotation speed is reached at which time the autopilot raises the elevator for rotation. A climb rate is followed for a set time, and then switched to flight mode and the UA proceeds to the next waypoint in the takeoff flight plan.

The UAS can also be launched by the SP using manual control. Once the aircraft is airborne, the SP enters the pattern and verifies UA controllability. During the controllability check the SP trims the UA for hands off flight. The UA is then set to "Auto" mode, which sends the aircraft to a pre-planned flight route that duplicates the traffic pattern. This is done to observe the UA response to autonomous flight while still in visual range of the observer.

The route varies with the runway in use, but is overlaid on the landing pattern. The distance will be approximately 1/2 mile upwind or downwind at landing pattern altitude and 1/2 mile abeam. The Pilot is verifying health, status, and proper GPS tracking. The Supplemental pilot can take manual control with a switch on the manual controller if required. The Pilot can rapidly change the waypoint, altitude or airspeed, or can select a heading to fly.

The Pilot has several options with autonomous flight control. The flight plan controls the waypoint, turn type, slope, and altitude. The altitude hold can be overridden by the Pilot, while the aircraft continues to navigate to the selected waypoint. Airspeed hold is always set by the Pilot independent of the flight plan. During pre-flight, the Pilot sets minimum and maximum limits on the airspeed, altitude, pitch angle, and roll angle, which prevents the autopilot from exceeding safe limits. The airspeed and altitude hold command value cannot be set to exceed the limits.

If desired the Pilot can override the waypoint navigation and set the aircraft to maintain a turn rate, or heading. The Pilot can also select a waypoint for "Direct To" navigation. Any waypoint previously loaded can be selected. Also the pilot can select a "loiter now" function, where the aircraft orbits around its current position. Given the "point and click" map interface for setting waypoints, any waypoint can be quickly and easily moved by dragging it to a new position on the map.

Two stability augmentation modes are available to assist with the manual pilot console. Steering Mode overrides the waypoint navigation allowing the SP or Pilot to steer the aircraft with the manual control stick, while maintaining airspeed and altitude hold. The manual control stick commands a turn rate proportional to the amount of stick deflection. Full Authority mode overrides waypoint navigation, altitude, and airspeed hold using the manual pilot console. Steering is accomplished the same as in Steering Mode, Altitude is set by throttle command, and airspeed is set by pitch command. For airspeed, the stick

# Raytheon

neutral pitch position will keep the UA at the current commanded airspeed hold, while pitch down/up will increase/decrease the airspeed proportional to the amount of stick deflection.

When required, the SP or Pilot can disconnect the autopilot from the flight controls by selecting manual control on the manual pilot console. All telemetry is available during manual operation.

When the flight is complete, the Pilot sends the UA to the pre-planned landing route. This is the Autoland function. These waypoints are designed to fly a landing pattern of a pre-selected length and glideslope to a specific landing point. A flair altitude and speed is set, and there is an option to kill the engine at the flair altitude. The pilot can select "go-around" with the push of a button which forces the aircraft back to the first point of the landing plan, or he can select any other waypoint or flight mode as described above. This is the normal landing mode for Raytheon.

If the Pilot chooses, he can use the stability augmentation modes to fly the pattern using his telemetry, instrumentation, and video to land the UA.

The RC controller is hard wired to the datalink for the Supplemental pilot. At any time he can take manual control by a switch and land using the manual controller.

## 14. Control Stations

- Provide a description of the ground/airborne stations used to control the UAS.

The GCS is composed of 1-4 laptop computers, a ground datalink module, and a power supply. These can be used in any shelter, or in the open. The manual pilot console is connected directly to the ground datalink module, and remains functional in the event of computer failure. Raytheon uses a panel truck to house all the equipment and provide environmental protection. An intercom system is installed allowing for crew communications during flight. An aviation band VHF radio is connected so that all voice communications are heard by the flight and ground crews. All video and voice communications are recorded onto a digital recorder.

The minimum configuration for flight is a laptop with the Piccolo Operator Interface (OI) pilot console software, the Piccolo ground datalink module, and Piccolo manual pilot console. The Piccolo OI has a moving map display, and screens for commanding all modes of flight and for observing all status telemetry received from the UA. See Appendix B. The maps used by Raytheon for the Piccolo OI are exported from the Falcon View PFPS route planning software. Falcon View is updated with current ECHUM and DAFIF information on a 28 day cycle. All telemetry files are logged onto the computer, and are archived during postflight. Visual and audible alarms are used to warn the operator of RPM, Altitude, Airspeed, System, Datalink (Comms) and GPS errors. There are additional data points in the displayed telemetry, but these are the only ones with an alert.

Additional computers can be added and networked together for additional functionality. MVCS consisting of a CUCS and VSM can be connected giving the pilot a virtual MFD. The CUCS pilot console has a moving map display, a PFD, and other displays for

commanding all flight modes and receiving all status telemetry and the moving map display will show the location of every UA on the network. The VSM can be hosted on the GCS computer or in the ECM aboard the UA.

Both the Piccolo OI and the MVCS can manage up to 4 aircraft simultaneously, or a pilot console can be added to the network for each UA.

## 15. Control Frequencies

- Provide a description/listing of the frequencies used to control the UAS.
  - o Microlight (Raytheon) Datalink
  - o Primary: 420-450 MHz
  - o Microhard (Piccolo) Datalink
  - o Secondary: 902-928 MHz
- Video Datalink
  - o Blackwidow 2.4 GHz
  - o <http://www.blackwidowav.com/bwav240200urban.html>
  - o GMS 2.4 GHz
  - o [http://www.gmsinc.com/product\\_details.asp?prod\\_idno=105](http://www.gmsinc.com/product_details.asp?prod_idno=105)
- Frequency Manager Points of Contact:
  - o FAA Western Pacific Region  
Frequency Management Officer  
AWP-471  
Sidney Bradfield  
Federal Aviation Administration, Western-Pacific Region  
15000 Aviation Boulevard  
Hawthorne, CA 90250  
310-725-3671  
[sydney.bradfield@faa.gov](mailto:sydney.bradfield@faa.gov)

o



# Raytheon

- DoD Area Frequency Coordinator State of Arizona  
Rod Hanson  
Arizona Ave Bldg 85846  
Ft. Huachuca, Arizona 85613-5000  
520-538-6423  
[rodney.hanson@us.army.mil](mailto:rodney.hanson@us.army.mil)
- Raytheon Frequency Coordinator  
Thomas J. Fagan  
Raytheon Missile Systems  
E3 & Spectrum Management  
P.O. Box 11337  
Bldg M02 M/S T16  
Tucson Arizona 85734-1337  
520-794-0227  
[tjfagan@raytheon.com](mailto:tjfagan@raytheon.com)

## Appendix A - Cobra Drawings and Photographs

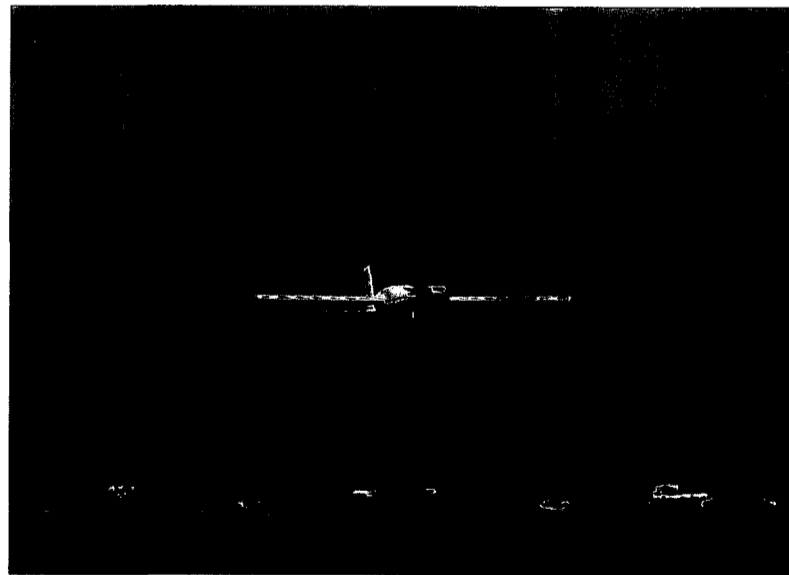
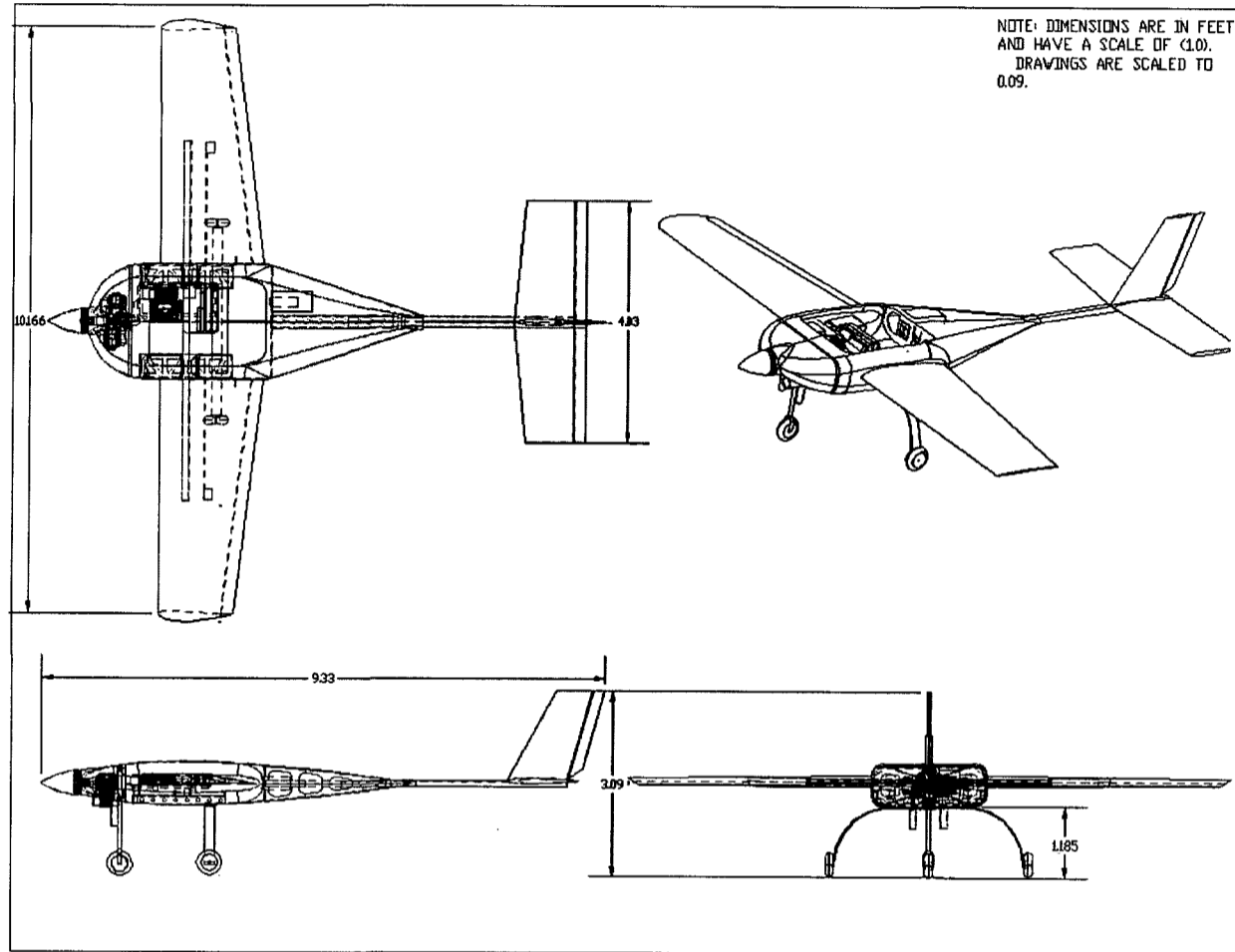

# Raytheon

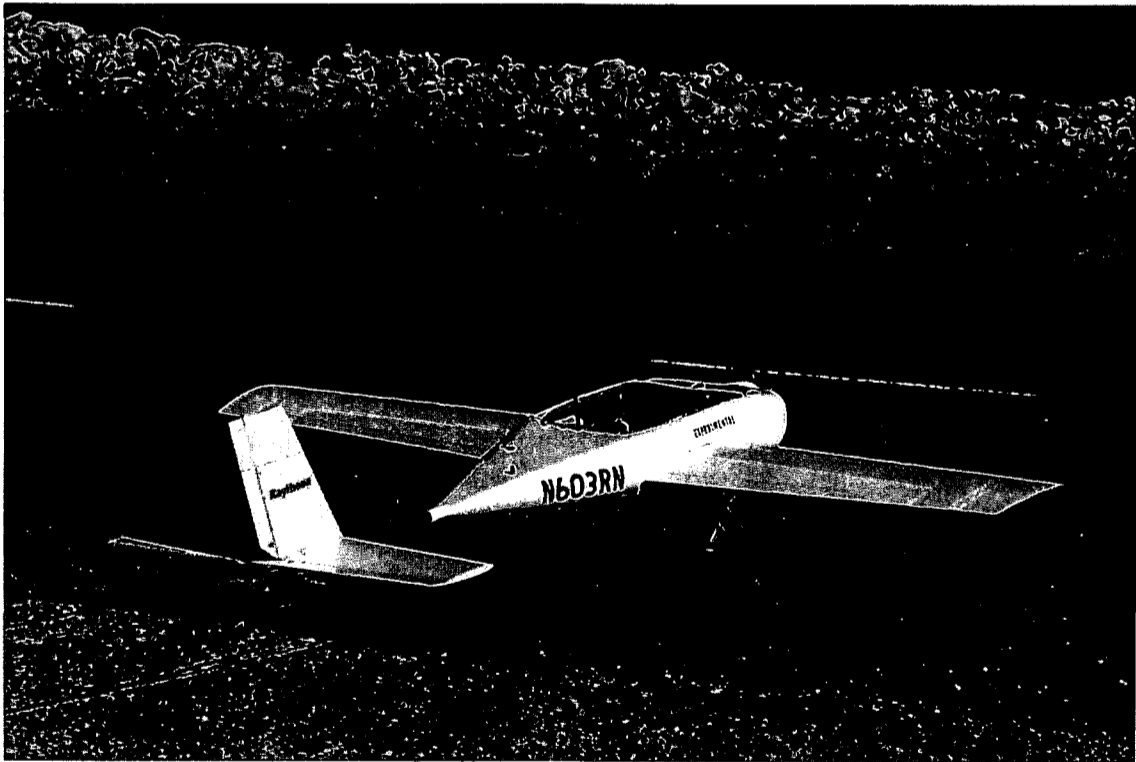

Raytheon

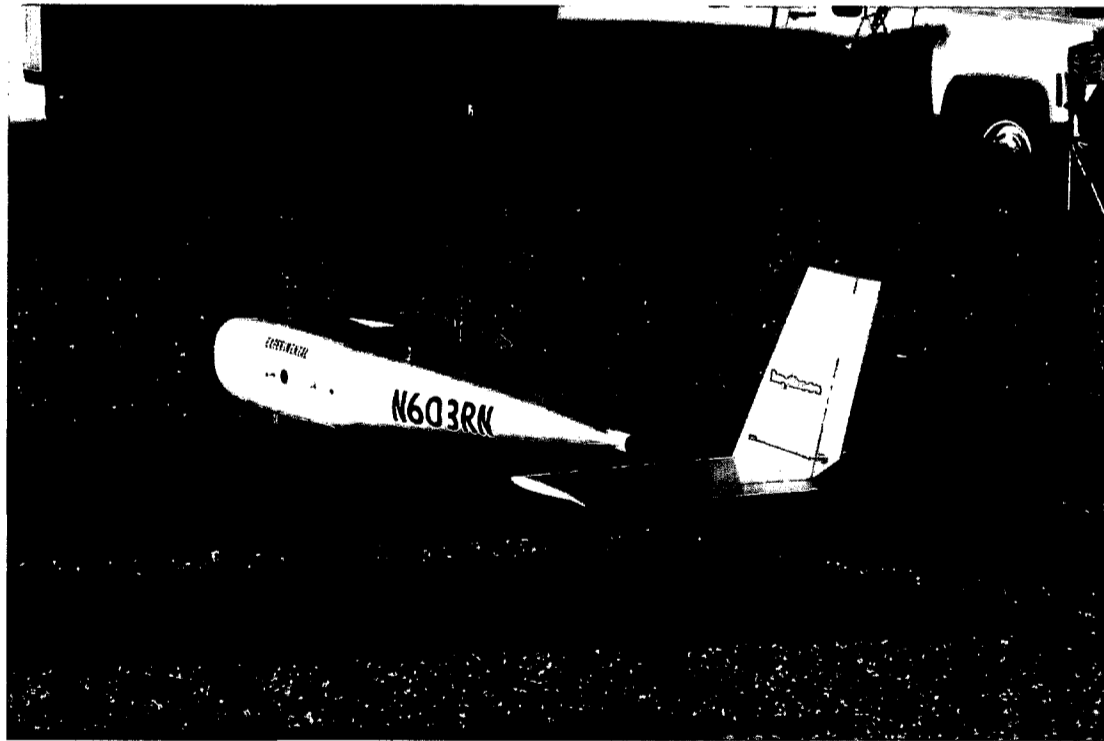
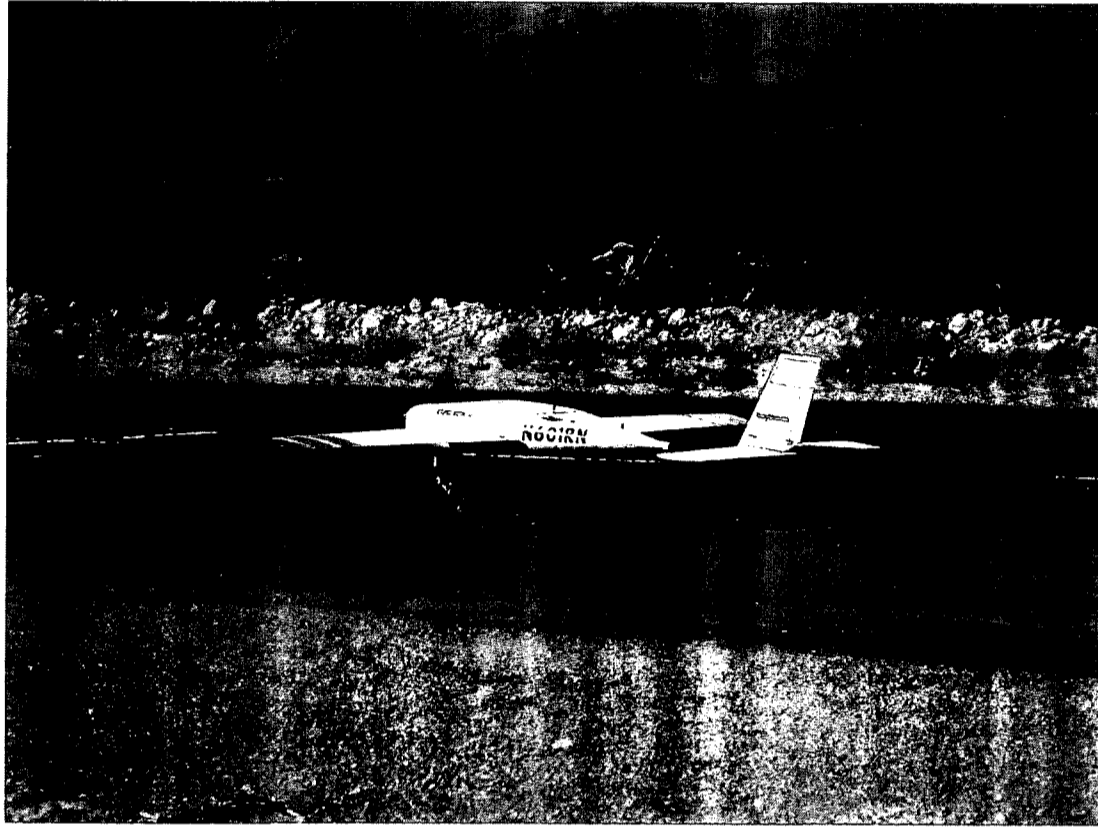

---

**Raytheon**

*Appendix B - Cloud Cap Piccolo II Users Guide*

Separate Document

## Appendix C - Raytheon UAS Flight Manual

Separate Document

### Appendix D - Cobra Weight and Balance

This is a preflight planning tool. It is not real-time, in that the "system" does not constantly compute the CG based on fuel burn. The Wt and Bal is conducted before each flight based on the weight and arm of the variable items. Given the test nature of our operations, Raytheon will conduct a full weighing of the aircraft before a flight if required.

COBRA

Raytheon UAS Weight and Balance				
AIRCRAFT	Cobra N601RN		DATE	9/27/2007
MAX TOWWEIGHT	105.0		Datum 0=Spinner Nose	
MAX USEFUL LOAD	43.4			
MAX PAYLOAD W/FULL FUEL	18.6			
	WEIGHT	MOMENT/1000	ARM	
<b>EMPTY WEIGHT</b>	<b>61.60</b>	<b>1.84</b>	<b>29.90</b>	
Battery	0.00	0.00	0.00	
Covering Battery	0.00	0.00	0.00	
Battery	1.45	0.00	15.25	
Payload Tray	1.88	0.04	23.75	
Alt Data Link	0.00	0.00	0.00	
Alt Video Tx	0.00	0.00	0.00	
TASE Payload	0.00	0.00	0.00	
Navstar	0.62	0.02	29.13	
	0.00	0.00	0.00	
Left Fuel (Enter, Gal)	0.75	4.65	23.75	
Right Fuel (Enter, Gal)	0.75	4.65	23.75	
<b>TOTALS</b>	<b>74.85</b>	<b>2.15</b>		
<b>CG</b>	<b>28.69</b>			

Empty Weight without Fuel, Alt C2, Payload Tray & Batteries. Includes video tx and wing camera, autopilot, C2 link, Transponder, and strobe.

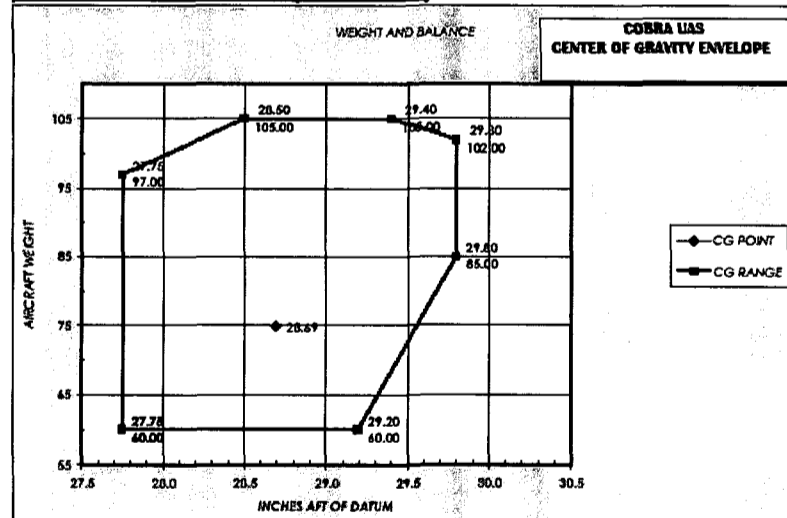

## Appendix E - Minimum Equipment List

The Minimum Equipment List (MEL) for this UAS will be used to show optional equipment configurations. Since all flight operations will be done in day VFR conditions, there will not be an option for night operations. However, the difference between a local flight and a range flight beyond 1 NM from the launch site will be delineated.

R – Required N – Not Required

Sub-System	Local Flight	Range Flight
Piccolo II Autopilot	R	R
Brakes	R	R
Generator	R	R
Regulator	R	R
Strobe Light	R	R
Transponder	R	R
Altitude Encoder	R	R
Magnetometer	R	R
Piccolo GCS	R	R
Manual Pilot Controller	R	R
MVCS	N	N
MicroHard Datalink and Antenna	R	R
MicroLight Datalink and Antenna	N	N
NetFires Datalink and Antenna	N	N
Video Transmitter and Antenna	N	N
Video Camera – Fixed	N	N
Video Camera – Gyro-Stabilized	N	N
Embedded Computer Module	N	N
DA-150 16 Hp Engine (W/Ign Module)	R	R
150 Muffler Set (W/Bolts, Gaskets, Plug Screws)	R	R
Mejlik 30x12 Propeller	R	R
IGN Sensor	R	R
RPM Sensor	R	R

# Raytheon

Hitec Hsc-5955 Titanium Gear High Speed Servo S	R	R
Robart 168 Fill Valve/Fill Chuck	R	R
Dubro In-Line Fuel Filter	R	R
Robart 192 Large Pressure Tank	R	R
Dubro Dura-Collars 3/16" (4)	R	R
Robart 173 On Board Pressure Gauge	R	R
SLA 1.6 Gallon Tank	R	R
Dubro Fuel Tank 1500cc 50 Oz.	N	N
Fourmost Fitting Tee Large (4)	R	R
Sullivan Aluminum Nipple Fitting	R	R
Dubro Tygon Gas Tubing	R	R
Dubro Heavy Duty Ball Links 4-40 (12)	R	R
Dubro Threaded Rod 4-40 12" (24)	R	R
Sullivan UAV Generator W/Regulator	R	R
Trailing link shock strut nose gear	R	R
Brake Hub Set For The 5" To 6" Tuff Tread Aluminum Wheels	R	R
8 Spoke Brake Hub 6"	R	R
Heavy Duty Switch Harness With Charge Jack	R	R
GPS Cable Long SMA - Push On	R	R
GPS Cable Short SMA - SMA	R	R
Engine Mount Standoffs	R	R
Dzus Fasteners For Payload Hatch	R	R
Landing Gear Main Strut	R	R
I Hooks Hold Down Bolts	R	R
Nylon Tail Boom Attach Bolt	R	R
Engine Mount Bolts	R	R
Main Gear Attachment Hardware	R	R
Large Washer For Nose Wheel Strut	R	R
Dust Cover Cap For Air Fill Port	R	R
Brackets For Anti -Rotation	R	R



## Raytheon

Nose Wheel Strut Mounts	R	R
Nose Wheel Steering Control Arm	R	R
GPS Antenna	R	R
GPS Filter	R	R
Pitot/Static Tube	R	R
Prop Bolts	R	R
Spinner Bolt	R	R
Panel Mount Mini-Din Connector For Brake Controller Unit (5-Pin Elliott)	R	R
Male 5 Pin Din	R	R
Female 5 Pin Din	R	R
4-40 Metal Clevis	R	R
Deans Connectors	R	R
Control Horns Wing, Elevator, Rudder	R	R
Inline Futaba Connectors And Ext Cables	R	R
Inline Air Fitting For Pitot Tube Hoses	R	R
RED & BLACK Anderson Type Connectors (Ign Pwr, Eng Kill)	R	R
Servo Mount Blocks For Throttle Servo And Steering Servo	R	R
Mounting Provisions For Servos Installed In Tail Surfaces	R	R
NACA Air Scoop	R	R
Aft Fuselage Exhaust Vent Assembly	R	R
Power Control Module	R	R
SLS Pitot Tube Housing	R	R
Payload Tray For Ballast CG Testing	N	N
Spacer In Nose Wheel Strut To Compress Spring	R	R
Rubber Shock Mounts For Gen Voltage Regulator	R	R
Piccolo Connector (44 Pin)	R	R
SMA Feed Thru For Piccolo UHF Antenna	R	R
Piccolo UHF Antenna Coax SMA-SMA	R	R
10 K Ohm Resistor For Rpm Sensor	R	R

# Raytheon

Hose Clamps For Pitot Tubes	R	R
Connector For Piccolo II Payload Port	R	R
Metal Threaded Inserts In Wings To Secure Pitot Tube Housing	R	R
Bud Box For Brake Controller Unit 3.5 X 1 5/8 X 2"	R	R
Tail Skags (Great Planes, Aka Wingtip Skids)	R	R
Tail Boom Carbon Wrapped Tube 6' 1.0" ID,0.06" WT,56 G./Ft.	R	R
Wing Spar 1.25" ID, Cello-Wrapped.	R	R
Ballast Weights	N	N

## Appendix F - System Configuration Diagram

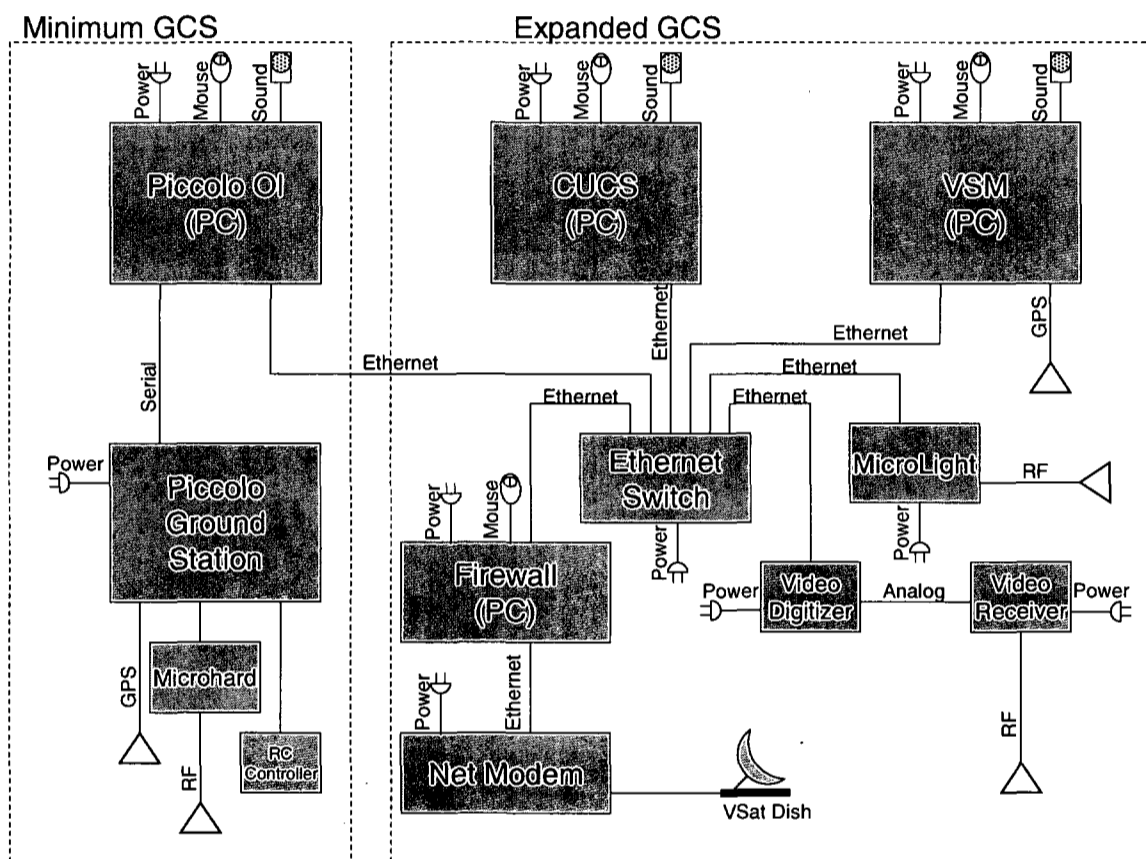

### A Minimum GCS

This is the basic Cloud Cap Piccolo Ground Station delivered by the autopilot manufacturer. Can operate as a stand alone Ground Control Unit, or be expanded via ethernet connection. External power is provide by a 1500 watt Uninterruptible Power Supply (UPS) (not shown).

<http://www.cloudcaptech.com/>

#### 1 Piccolo Operator Interface (OI)

- (a) Pilot and Sensor interface (software) running on a laptop PC. Windows Operating System. Connects to Piccolo Ground Station Module via serial interface.
- (b) Laptop contains battery backup.
- (c) Connects to Expanded GCS via Ethernet.

#### 2 Piccolo Ground Station (Module)

- (a) An enclosed 8x6x4 hardware unit consisting of a Piccolo Autopilot Card, GPS, Microhard Transmitter/Receiver, and internal battery backup.
- (b) Connects to and provides power for the RC controller, and provides external antenna connections.

### **3 Microhard Datalink**

- (a) Internal to the Piccolo Ground Station Module. Provides 1 watt transmit and receive on 900 MHz spread spectrum datalink.
- (b) Passes command and control inputs to, and receives telemetry data from the aircraft
- (c) <http://www.microhardcorp.com/>

### **4 RC Controller**

- (a) A standard off the shelf Remote Control (RC) model controller with the battery and TX/RX module removed. Connected to the Ground Station module via the buddy cord interface. Receives power from the Ground Station module. Provides manual pilot control of the aircraft, and switches from manual to automatic control.
- (b) Is not required for system function. If disconnected, and configured correctly, the system defaults to automatic.

## **B Expanded GCS**

Multi-Vehicle Control System (MVCS), MicroLight datalink, extended communications and video processing. External power is provide by a 1500 watt UPS (not shown).

### **1 Common UAS Control System (CUCS)**

- (a) Sub-component of the MVCS
- (b) One of two STANAG 4586 compliant modules. Pilot and Sensor interface (software) running on a laptop PC. Linux Red Hat Operating System. Connects to Piccolo OI via ethernet interface.
- (c) Can run on the same laptop as the VSM or independently.
- (d) Multiple CUCS can be connected via the ethernet hub to provide additional pilot or sensor controls.
- (e) STANAG 4586 – NATO standard for UAS communications
- (f) Laptop contains battery backup.
- (g) Can be configured to use the Microhard datalink or the MicroLight datalink.

### **2 Vehicle Specific Module (VSM)**

- (a) Sub-component of the MVCS
- (b) Second of two STANAG 4586 compliant modules. Telemetry interface (software) running on a laptop PC on an airborne processor. Linux Red Hat Operating System. Connects to CUCS via ethernet interface or to aircraft via datalink.
- (c) Can run on the same laptop as the CUCS or independently.

---

# Raytheon

(d) Can be hosted on the ground or in the aircraft.

(e) Laptop contains battery backup.

### 3 Ethernet Switch

(a) Gigabit ethernet switch provides communications pathway between elements.

### 4 MicroLight

(a) Raytheon produced software radio, used as a digital networked datalink.

(b) <http://www.raytheon.com/products/microlight/>

### 5 Firewall PC

(a) Laptop running firewall application to allow secure connection to Raytheon Intranet.

### 6 Net Modem

(a) Provides connection to VSat Commercial Satellite Link

### 7 VSat

(a) Provides commercial satellite connection to Raytheon Intranet.

(b) Can be used to disseminate UAS telemetry and sensor imagery.

(c) Can be used to receive weather, maps, mission plans and track data.

### 8 Video Digitizer

(a) Digitizes analog video signal to digital output for viewing and dissemination.

### 9 Video Receiver

(a) Receives analog video signal from the aircraft.

**Raytheon**



*Appendix G - FAA UAS Safety Checklist*

Separate Document



*Appendix H – Acronym List*

<b>A</b>		<b>I</b>	
AGL		IFR	
Above Ground Level .....	4	Instrument Flight Rules .....	5
ATIS		IP	
Automatic Terminal Information Service .....	16	Internal Pilot .....	13
<b>C</b>		<b>J</b>	
CFR		JTRS	
Code of Federal Regulations .....	3	Joint Tactical Radio System .....	10
COTS		<b>K</b>	
Commercial Off-The-Shelf .....	9	KIAS	
CUCS		Knots Indicated Airspeed .....	7
Core UAV Control Station .....	10	KTS	
<b>D</b>		Knots .....	7
DAFIF		<b>L</b>	
Digital Aeronautical Information File .....	20	LUAV	
DGPS		Lethal Unmanned Aerial Vehicle .....	14
Differential Global Positioning System .....	8	<b>M</b>	
DoD		MAV	
Department of Defense .....	4	Micro Air Vehicle .....	14
DR		MEL	
Dead Reckoning .....	18	Minimum Equipment List .....	29
<b>E</b>		MEMS	
ECHUM		Micro-Electro-Mechanical Systems .....	8
Electronic Chart Updating Manual .....	20	MFD	
EMI		Multi-Function Display .....	10
Electro-Magnetic Interference .....	7	MHX	
EP		Multi-Plex .....	9
External Pilot .....	5	MHz	
EPLRS		Mega-Hertz .....	10
Enhanced Position Location Reporting System .....	10	MOA	
<b>F</b>		Military Operating Area .....	5
FAA		MRA	
Federal Aviation Administration .....	4	Minimum Reception Altitude .....	5
FCC		MSL	
Federal Communications Commission .....	7	Mean Sea Level .....	4
<b>G</b>		MVCS	
GCS		Multi-Vehicle Control System .....	11
Ground Control Station .....	16	<b>N</b>	
GHz		NOTAM	
Giga-Hertz .....	9	Notice to Airmen .....	4
GPS			
Global Positioning System .....	8		

**O**

OI  
Operator Interface ..... 20

**P**

PFD  
Primary Flight Display..... 10

PFPS  
DoD Portable Flight Planning System ..... 20

PIC  
Pilot in Command ..... 13

**R**

RC  
Remote Control..... 13

RFI  
Radio Frequency Interference ..... 7

RX  
Receive ..... 34

**S**

SE  
Southeast..... 5

SP  
Supplemental Pilot..... 13

STANAG  
NATO Standardizaion Agreement..... 10

SUAV  
Small Unmanned Aerial Vehicle ..... 14

SW  
Southwest ..... 5

**T**

TRR  
Test Readiness Review..... 12

TX  
Transmit ..... 34

**U**

UA  
Unmanned Aircraft..... *Unmanned Aircraft System*

UAS  
Unmanned Aircraft System ..... 2

UAV  
Unmanned Aerial Vehicle..... 10

UHF  
Ultra High Frequency..... 9

UPS  
Uninterruptible Power Supply..... 33

UVI  
Unmanned Vehicles International ..... 3

**V**

VFR  
Visual Flight Rules..... 7

VHF  
Very High Frequency ..... 20

VMC  
Visual Meteorological Conditions..... 7

VR  
Military VFR Training Route..... 5

VSM  
Vehicle Specific Module..... 10