

SECURITY CLASSIFICATION

NSA STAFF PROCESSING FORM

TO DIRECTOR		EXREG CONTROL NUMBER	KCC CONTROL NUMBER IG-10262-03	
THRU D/DIR _____, D SECRETARIAT _____		ACTION <input type="checkbox"/> APPROVAL <input checked="" type="checkbox"/> SIGNATURE <input type="checkbox"/> INFORMATION		EXREG SUSPENSE KCC SUSPENSE ELEMENT SUSPENSE
SUBJECT Quarterly Report to the Intelligence Oversight Board on NSA Activities—Fourth Quarter FY03 (U//FOUO)				
DISTRIBUTION				

SUMMARY

PURPOSE: (U//~~FOUO~~) To forward to the Intelligence Oversight Board (IOB) of the President's Foreign Intelligence Advisory Board, via the Assistant to the Secretary of Defense for Intelligence Oversight (ATSD(IO)), NSA's quarterly report on its intelligence activities.

BACKGROUND: (U//~~FOUO~~) Executive Order 12333 and Executive Order 12863 require Intelligence Community agency heads and Intelligence Community General Counsels and Inspectors General, respectively, to report to the IOB on a quarterly basis concerning intelligence activities that they have reason to believe may be unlawful or contrary to Executive Order or Presidential Directive. The enclosed memorandum covers all reportable activities known to the Inspector General and General Counsel. Per PIOB letter of 6 August 1982, Agency heads are responsible for reporting separately any additional reportable activities known to them, unless the President has specifically instructed that the Board is not to be informed. The Director's signature signifies that no other activities that require reporting are known to him.

RECOMMENDATION: (U//~~FOUO~~) Director sign the enclosed memorandum.

Approved for Release by NSA on 06-01-2009, FOIA Case # 49107

DECLASSIFY UPON REMOVAL OF THE ENCLOSURE(S)

COORDINATION/APPROVAL

OFFICE	NAME AND DATE	SECURE PHONE	OFFICE	NAME AND DATE	SECURE PHONE
ActingGC	Vito Potenza	5548s			
AGC(O)		3121s			
IG	Joel F. Bren <i>JFB 11-19-03</i>	3544s			
D/IG	<i>BMC 11/19</i>	3544s			
AIG(IO)	<i>Jo 11/19</i>	3544s			
			ORG	PHONE (Secure)	DATE PREPARED
			D11	963-2984	19 November 2003
			123-2	SECURITY CLASSIFICATION TOP SECRET//COMINT//NOFORN//X1	

(b) (3) - P.L. 86-36



NATIONAL SECURITY AGENCY
CENTRAL SECURITY SERVICE
FORT GEORGE G. MEADE, MARYLAND 20755-6000

25 November 2003

MEMORANDUM FOR THE CHAIRMAN, INTELLIGENCE OVERSIGHT BOARD

THRU: Assistant to the Secretary of Defense (Intelligence Oversight)

SUBJECT: (U//~~FOUO~~) Report to the Intelligence Oversight Board on NSA
Activities - INFORMATION MEMORANDUM

(U//~~FOUO~~) Except as previously reported to you or the President, or otherwise stated in the enclosure, we have no reason to believe that any intelligence activities of the National Security Agency during the quarter ending 30 September 2003, were unlawful or contrary to Executive Order or Presidential Directive, and thus required to be reported pursuant to Section 1.7.(d) of Executive Order 12333.

(U//~~FOUO~~) The Inspector General and the General Counsel continue to exercise oversight of Agency activities by means of inspections, surveys, training, review of directives and guidelines, and advice and counsel. These activities and other data requested by the Board or members of the staff of the Assistant to the Secretary of Defense (Intelligence Oversight) are described in the enclosure.

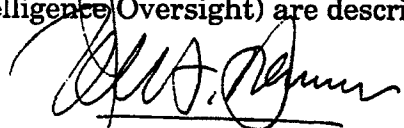
JOEL F. BRENNER
Inspector General

VITO T. POTENZA
Acting General Counsel

(U//~~FOUO~~) I concur in the report of the Inspector General and the General Counsel and hereby make it our combined report.

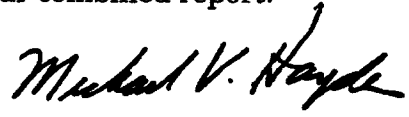
MICHAEL V. HAYDEN
Lieutenant General, USAF
Director, NSA/Chief, CSS

Encl:
a/s

This Memorandum is Unclassified
Upon Removal of Enclosure

DERIVED FROM: NSA/CSSM 123-2
DATED: 24 FEB 98
DECLASSIFY ON: X1

1. (U) INSPECTOR GENERAL ACTIVITIES

a. ~~(C//SI)~~ During this quarter, the Office of Inspector General (OIG) reviewed various intelligence activities of the National Security Agency/Central Security Service (NSA/CSS) to determine whether they were conducted in accordance with applicable statutes, Executive Orders, Attorney General procedures, and DoD and internal directives. With few exceptions, the issues presented were routine and indicated that the operating elements understand the restrictions on NSA/CSS activities.

b. ~~(C)~~ The NSA OIG completed an inspection of the office of the [redacted] [redacted] The report concluded that the intelligence oversight (I/O) program is compliant. All employees receive quarterly I/O refresher training, at which time they read relevant I/O documents on the NSA Intranet. The I/O point of contact maintains records of the training.

(b)(1)
(b)(3)-P.L. 86-36

c. ~~(U//FOUO)~~ Along with inspectors from [redacted] [redacted] the NSA OIG completed an inspection of the [redacted] [redacted] The joint inspection report noted that the site's I/O program training and documentation are sound and meet minimum requirements. The I/O program manager continuous to improve the overall program and has an excellent understanding of I/O. However, I/O knowledge levels vary greatly at the [redacted] operations personnel have good knowledge of I/O, but overall site I/O knowledge is weaker. The I/O program manager has thus undertaken to increase and sustain the overall knowledge level of non-operations personnel.

(b)(3)-P.L. 86-36

2. (U) GENERAL COUNSEL ACTIVITIES

~~(C//SI)~~ The NSA Office of General Counsel (OGC) reviewed various intelligence activities of the NSA/CSS to determine whether they were conducted in accordance with applicable statutes, Executive Orders, Attorney General procedures, and DoD and internal directives. The OGC advised Agency elements on a number of questions, including the collection and dissemination of communications of or concerning U.S. persons; the reporting

DERIVED FROM: NSA/CSSM 123-2
DATED: 24 FEB 98
DECLASSIFY ON: X1

of possible violations of federal criminal law contained in SIGINT product; the testing of electronic equipment; and the applicability of the Foreign Intelligence Surveillance Act (FISA). With few exceptions, the issues presented were routine and indicated that the operating elements understand the restrictions on NSA/CSS activities. The OGC did not file any reports with the Intelligence Oversight Board during this quarter.

3. (U) SIGINT ACTIVITIES

(b)(3)-P.L. 86-36

a. (S//SI) [Redacted]

(1) (U) [Redacted]

(S//SI) [Redacted]

(b)(3)-P.L. 86-36

(b)(3)
(b)(3)-P.L. 86-36

(S//SI) [Redacted]

(b)(3)-P.L. 86-36

(2) (U) [Redacted]

(b)(3)-P.L. 86-36

a. (S//SI//NF) [Redacted]

(b)(1)
(b)(3)-50 USC 403
(b)(3)-18 USC 798
(b)(3)-P.L. 86-36

b. (S//SI) [Redacted]

(b)(1)
(b)(3)-50 USC 403
(b)(3)-18 USC 798
(b)(3)-P.L. 86-36

(b)(1)
(b)(3)-50 USC 403
(b)(3)-18 USC 798
(b)(3)-P.L. 86-36

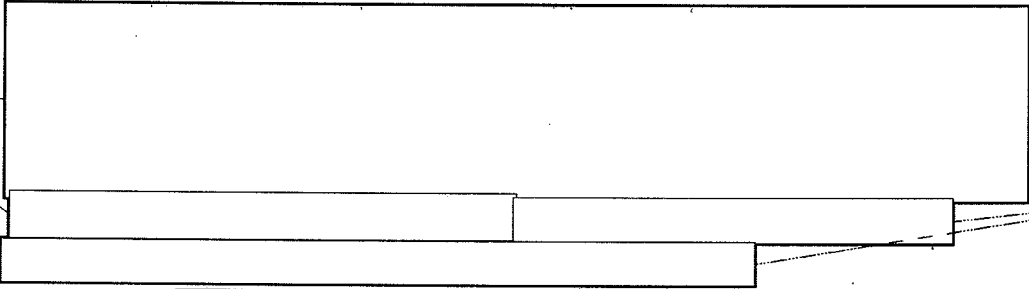

(b)(3)-P.L. 86-36

c. ~~(TS//SI)~~

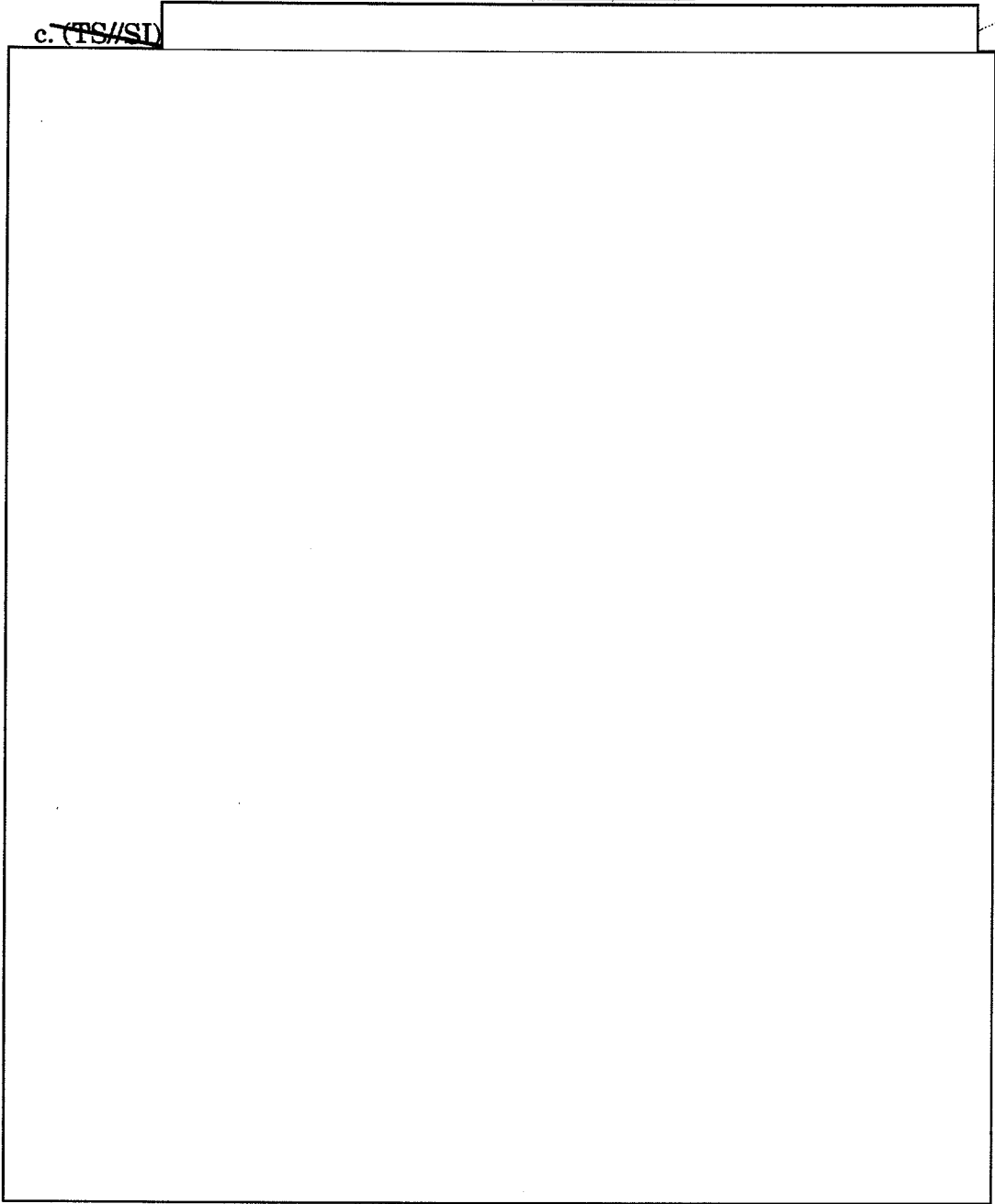

(b)(1)
(b)(3)-50 USC 403
(b)(3)-18 USC 798
(b)(3)-P.L. 86-36

[Redacted]

(b)(1)
(b)(3)-50 USC 403
(b)(3)-18 USC 798
(b)(3)-P.L. 86-36

f. ~~(TS//SI)~~

[Redacted]

g. ~~(TS//SI)~~

[Redacted]

(b)(1)
(b)(3)-50 USC 403
(b)(3)-P.L. 86-36
(b)(3)-18 USC 798

[Redacted]

(b)(3)-P.L. 86-36

h. ~~(S//SI//NF)~~

[Redacted]

(b)(1)
(b)(3)-P.L. 86-36

b. (U//FOUO)

[Redacted]

(b)(3)-P.L. 86-36

(1) (U)

[Redacted]

~~(S//SI)~~

[Redacted]

(b)(3)-P.L. 86-36

(b)(1)
(b)(3)-P.L. 86-36

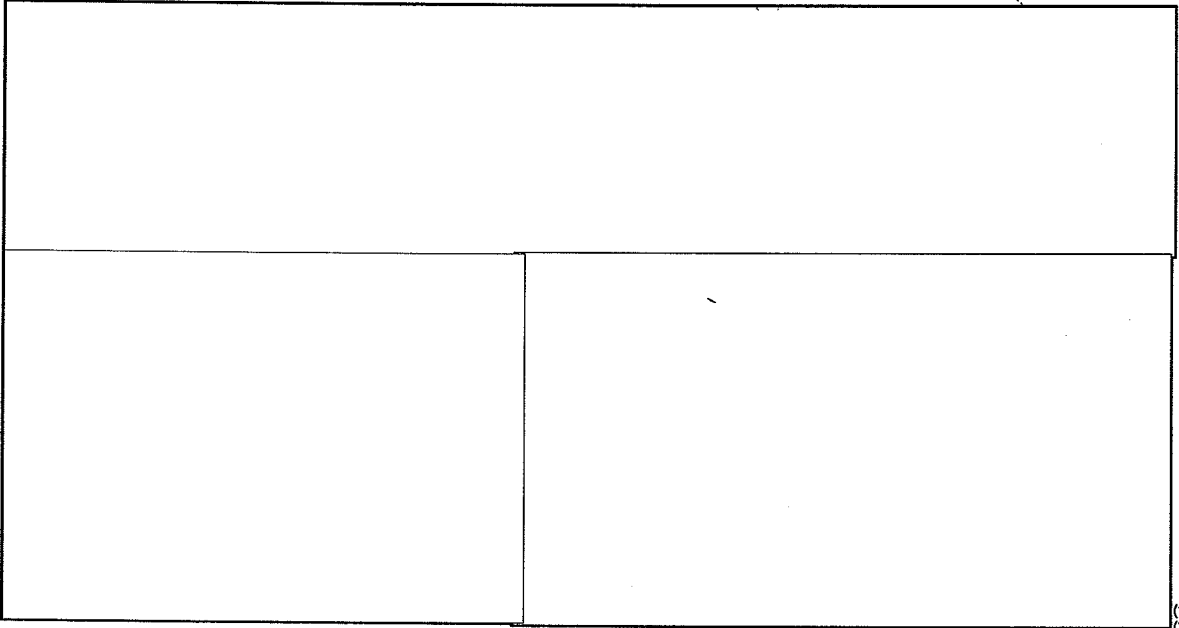

(b)(3)-P.L. 86-36

(b)(3)-P.L. 86-36

(1)
(3)-P.L. 86-36

(2) (U)



(S//SI)

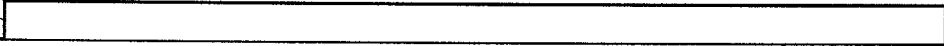

(3) (U)



(S//SI)

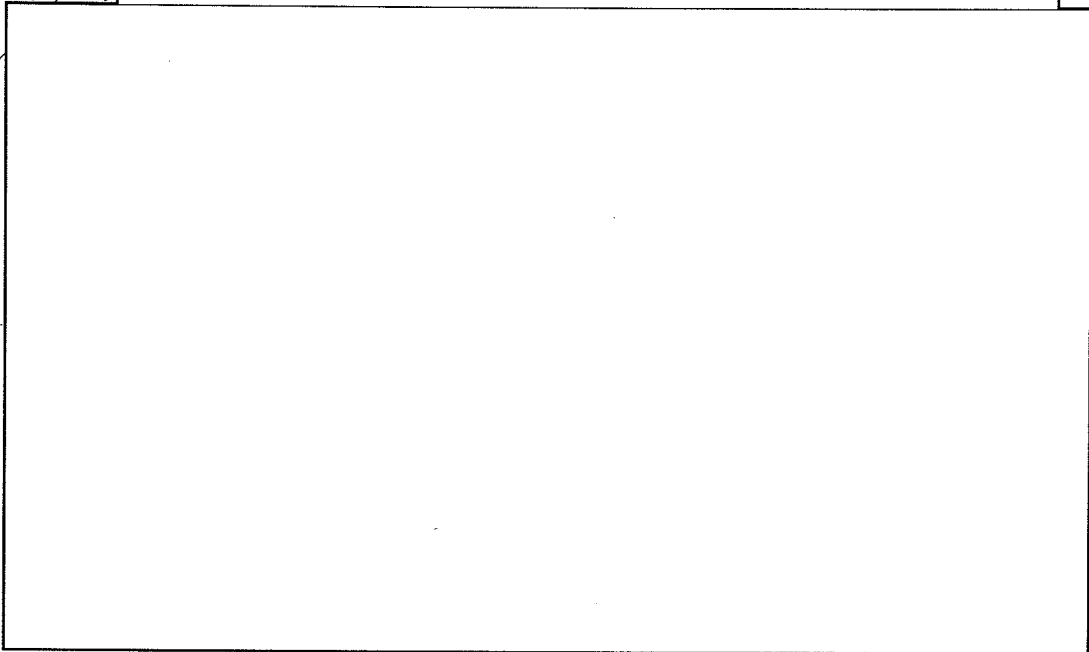

(b)(3)-P.L. 86-36

4. (U) OTHER ACTIVITIES

(U) Assistance to Law Enforcement

(S//SI) [Redacted]

[Redacted]

(b)(3)-P.L. 86-36

(U) Working Aids

(U//FOUO) The SID maintains [Redacted]

[Redacted] on its web page for use by all NSA/CSS

analysts. The E.O., NSA/CSS Regulation 10-30, DoD Regulation 5240.1-R,

and USSID 18 are also available on-line. [Redacted]

[Redacted]

(b)(3)-P.L. 86-36

(U) New Guidance

(S//SI) [Redacted]

[Redacted]

(b)(1)
(b)(3)-50 USC 403
(b)(3)-18 USC 798
(b)(3)-P.L. 86-36

SECURITY CLASSIFICATION

NSA STAFF PROCESSING FORM

TO DIRECTOR		EXREG CONTROL NUMBER 90458	KCC CONTROL NUMBER IG-10294-04	
THRU D/DIR 48 , D SECRETARIAT		ACTION <input type="checkbox"/> APPROVAL <input checked="" type="checkbox"/> SIGNATURE <input type="checkbox"/> INFORMATION		EXREG SUSPENSE KCC SUSPENSE ELEMENT SUSPENSE
SUBJECT (U//FOUO) Quarterly Report to the Intelligence Oversight Board on NSA Activities—First Quarter FY04				
DISTRIBUTION CY OCT03 - DEC 03				

SUMMARY

PURPOSE: (U//FOUO) To forward to the Intelligence Oversight Board (IOB) of the President's Foreign Intelligence Advisory Board, via the Assistant to the Secretary of Defense for Intelligence Oversight (ATSD(IO)), NSA's quarterly report on its intelligence activities.

BACKGROUND: (U//FOUO) Executive Order 12333 and Executive Order 12863 require Intelligence Community agency heads and Intelligence Community General Counsels and Inspectors General, respectively, to report to the IOB on a quarterly basis concerning intelligence activities that they have reason to believe may be unlawful or contrary to Executive Order or Presidential Directive. The enclosed memorandum covers all reportable activities known to the Inspector General and General Counsel. Per PIOB letter of 6 August 1982, Agency heads are responsible for reporting separately any additional reportable activities known to them, unless the President has specifically instructed that the Board is not to be informed. The Director's signature signifies that no other activities that require reporting are known to him.

RECOMMENDATION: (U) Director sign the enclosed memorandum.

This document may be declassified and marked "UNCLASSIFIED//For Official Use Only" upon removal of enclosure(s)

Approved for Release by NSA on 06-01-2009, FOIA Case # 49107

COORDINATION/APPROVAL

OFFICE	NAME AND DATE	SECURE PHONE	OFFICE	NAME AND DATE	SECURE PHONE
ActingGC	Vito Potenza 11/11/04	5548s	DCI	[Redacted] 2/5/04	
AGC(O)	[Redacted]	3121s			
IG	Doc F. Brenner 1/12/04	3544s			
D/IG	[Redacted]	3544s			
AIG(IO)	[Redacted]	3544s			

ORG 011	PHONE (Secure) 963-2984	DATE PREPARED 27 February 2004
-------------------	-----------------------------------	--



NATIONAL SECURITY AGENCY
CENTRAL SECURITY SERVICE
FORT GEORGE G. MEADE, MARYLAND 20755-6000

17 March 2004

MEMORANDUM FOR THE CHAIRMAN, INTELLIGENCE OVERSIGHT BOARD

THRU: Assistant to the Secretary of Defense (Intelligence Oversight)

SUBJECT: (U//~~FOUO~~) Report to the Intelligence Oversight Board on NSA
Activities - INFORMATION MEMORANDUM

(U//~~FOUO~~) Except as previously reported to you or the President, or otherwise stated in the enclosure, we have no reason to believe that any intelligence activities of the National Security Agency during the quarter ending 31 December 2003, were unlawful or contrary to Executive Order or Presidential Directive, and thus required to be reported pursuant to Section 1.7.(d) of Executive Order 12333.

(U//~~FOUO~~) The Inspector General and the General Counsel continue to exercise oversight of Agency activities by means of inspections, surveys, training, review of directives and guidelines, and advice and counsel. These activities and other data requested by the Board or members of the staff of the Assistant to the Secretary of Defense (Intelligence Oversight) are described in the enclosure.

Handwritten signature of Joel F. Brenner in black ink.

JOEL F. BRENNER
Inspector General

Handwritten signature of Vito T. Potenza in black ink.

VITO T. POTENZA
Acting General Counsel

(U//~~FOUO~~) I concur in the report of the Inspector General and the General Counsel and hereby make it our combined report.

Handwritten signature of Michael V. Hayden in black ink.

MICHAEL V. HAYDEN
Lieutenant General, USAF
Director, NSA/Chief, CSS

Encl:
a/s

This Memorandum is Unclassified

DERIVED FROM: NSA/CSSM 123-2
DATED: 24 FEB 98
DECLASSIFY ON: X1

1. (U) INSPECTOR GENERAL ACTIVITIES

a. ~~(C//SI)~~ During this quarter, the Office of Inspector General (OIG) reviewed various intelligence activities of the National Security Agency/Central Security Service (NSA/CSS) to determine whether they were conducted in accordance with applicable statutes, Executive Orders (E.O.s), Attorney General procedures, and DoD and internal directives. With few exceptions, the issues presented were routine and indicated that the operating elements understand the restrictions on NSA/CSS activities.

(b)(1)
(b)(3)-50 USC 403
(b)(3)-P.L. 86-36

b. ~~(S//SI)~~ The NSA OIG completed a review [redacted]. The review determined that [redacted] had appropriately reported compliance issues to the NSA OIG. Regarding intelligence oversight (I/O) training, [redacted] had initiated mandatory online training for all personnel, eliminating the previous separate and cumbersome I/O training processes for field and headquarters personnel. The on-line training module documents training completion in a database.

c. ~~(U//FOUO)~~ Along with inspectors from [redacted] the NSA OIG completed a follow-up inspection of the [redacted]. The joint inspection report notes that the site's web-based I/O refresher training program was rewritten, eliminating the deficiencies noted during the last inspection.

(b)(3)-P.L. 86-36

d. ~~(U//FOUO)~~ An OIG inspection of the [redacted] determined that the organization was compliant with E.O. 12333 and DoD Regulation 5240.1-R, as well as NSA/CSS Directive 10-30. The Division conducts annual I/O refresher training and routinely submits compliance reports to the OIG.

(b)(3)-P.L. 86-36

e. ~~(U//FOUO)~~ Inspectors from the [redacted] and NSA OIG completed a joint inspection of the Fort Gordon Regional Security Operations Center (GRSOC), GA. The inspectors concluded that all newcomers to the

(b)(3)-P.L. 86-36

DERIVED FROM: NSA/CSSM 123-2
DATED: 24 FEB 98
DECLASSIFY ON: X1

site receive I/O training from the Security Services Directorate, GRSOC, during initial security indoctrination; however, the initial I/O training videotape does not address some service-specific requirements. Annual refresher training is conducted via a computer-based module that tests and documents completion in a database. The inspectors tested 22 percent of the personnel at the site to gauge general I/O knowledge and the ability to apply it to site operations. The test results indicate a good understanding of the regulations governing I/O, but a slight weakness in practical application.

2. (U) GENERAL COUNSEL ACTIVITIES

~~(C//SI)~~ The NSA Office of General Counsel (OGC) reviewed various intelligence activities of the NSA/CSS to determine whether they were conducted in accordance with applicable statutes, E.O.s, Attorney General procedures, and DoD and internal directives. The OGC advised Agency elements on a number of questions, including the collection and dissemination of communications of or concerning U.S. persons; the reporting of possible violations of federal criminal law contained in SIGINT product; the testing of electronic equipment; and the applicability of the Foreign Intelligence Surveillance Act (FISA). With few exceptions, the issues presented were routine and indicated that the operating elements understand the restrictions on NSA/CSS activities. The OGC did not file any reports with the Intelligence Oversight Board during this quarter.

3. (U) SIGINT ACTIVITIES

a. ~~(S//SI)~~ [Redacted]

(1) (U) [Redacted]

~~(S//SI)~~ [Redacted]

~~(S//SI)~~ [Redacted]

(2) (U) [Redacted]

a. ~~(C//SI)~~ [Redacted]

(b)(1)
(b)(3)-P.L. 86-36

(b)(3)-P.L. 86-36

(b)(3)-P.L. 86-36

(b)(1)
(b)(3)-50 USC 403
(b)(3)-18 USC 798
(b)(3)-P.L. 86-36

~~TOP SECRET//COMINT//ORCON//NOFORN//X1~~

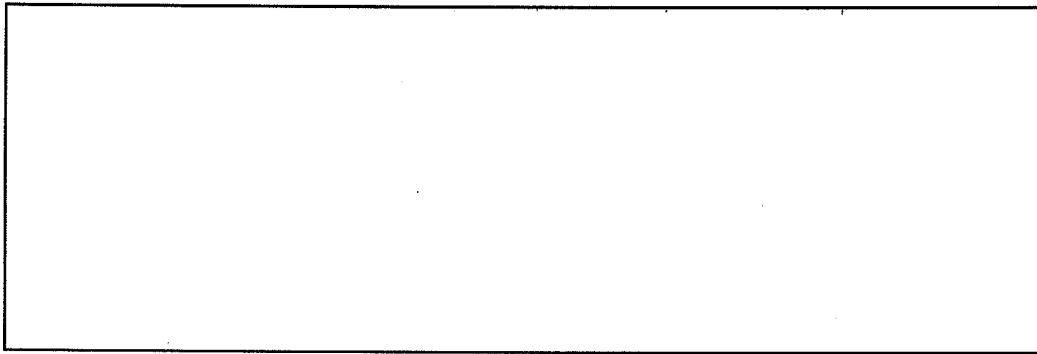

(b)(3)-P.L. 86-36

b. ~~(TS//SI//NF)~~

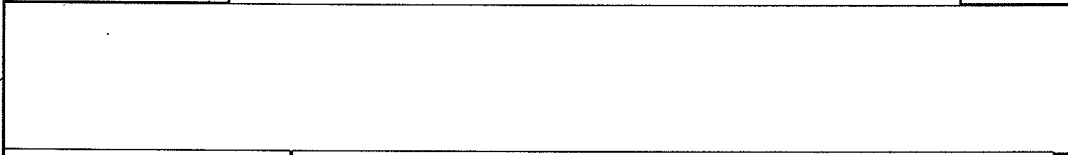

(b)(3)-P.L. 86-36

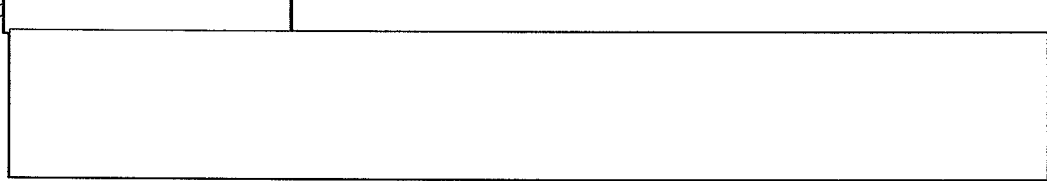

c. ~~(S//SI)~~

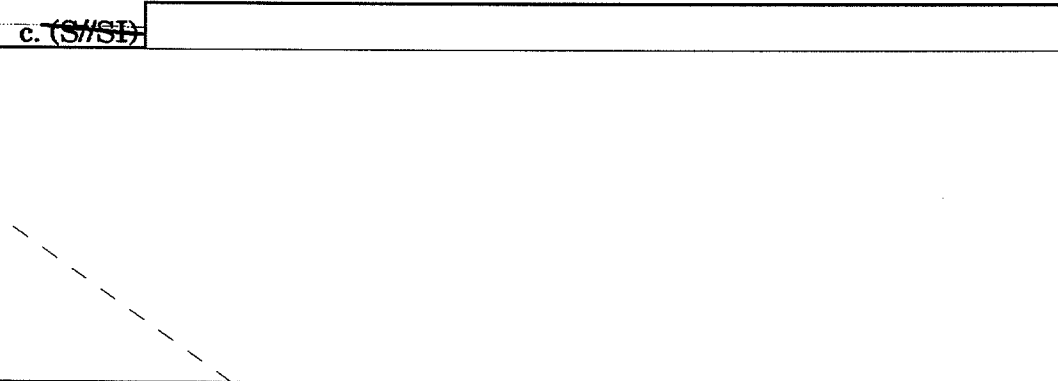

d. ~~(TS//SI//OC//NF)~~

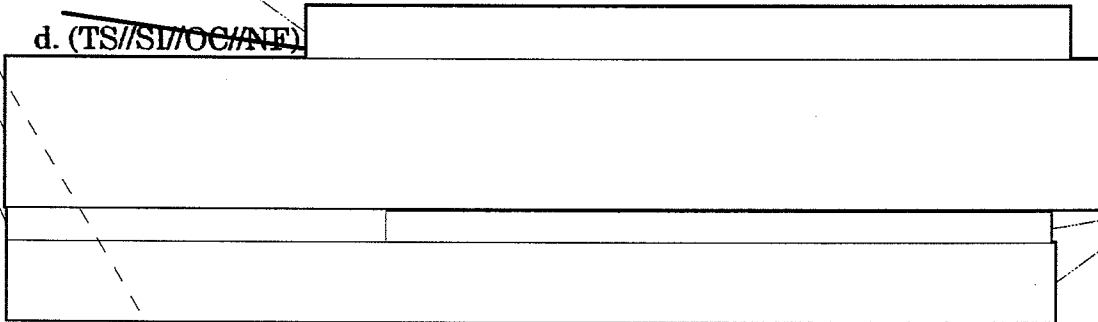

(b)(3)-P.L. 86-36

e. ~~(TS//SI)~~

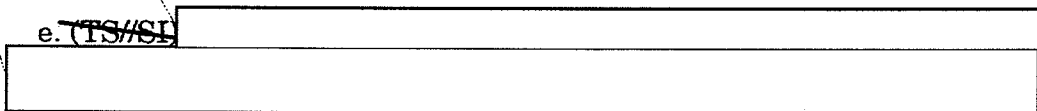

(b)(1)
(a)(3)-50 USC 403
(b)(3)-18 USC 798
(b)(3)-P.L. 86-36

~~TOP SECRET//COMINT//ORCON//NOFORN//X1~~

~~TOP SECRET//COMINT//ORCON//NOFORN//XI~~

(b)(1)
(b)(3)-50 USC 403
(b)(3)-18 USC 798
(b)(3)-P.L. 86-36

(b)(3)-P.L. 86-36

[Redacted]

f. (TS//SI)

[Redacted]

(b)(1)
(b)(3)-50 USC 403
(b)(3)-P.L. 86-36

g. (TS//SI)

(b)(3)-P.L. 86-36

[Redacted]

(b)(1)
(b)(3)-50 USC 403
(b)(3)-18 USC 798
(b)(3)-P.L. 86-36

(b)(3)-P.L. 86-36

h. (S//SI//NF)

(b)(1)
(b)(3)-P.L. 86-36

[Redacted]

b. (U//FOUO)

(b)(3)-P.L. 86-36

(1) (U)

(S//SI)

(b)(1)
(b)(3)-P.L. 86-36

[Redacted]

~~TOP SECRET//COMINT//ORCON//NOFORN//XI~~

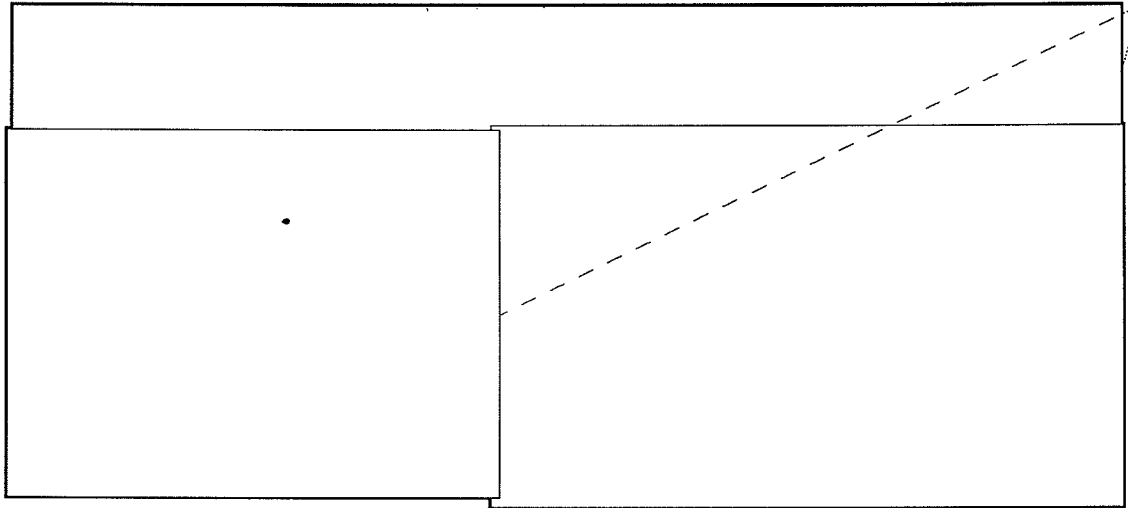

(b)(3)-P.L. 86-36

(b)(3)-P.L. 86-36

(2) (U) [redacted]

(b)(3)-P.L. 86-36

(b)(1)
(b)(3)-P.L. 86-36

(S//SI) [redacted]

(3) (U) [redacted]

(b)(1)
(b)(3)-P.L. 86-36

a. (TS//SI) [redacted]

[redacted]

b. (S//SI) [redacted]

(b)(3)-P.L. 86-36

[redacted]

(b)(3)-P.L. 86-36

[Redacted]

4. (U) OTHER ACTIVITIES

(U) Assistance to Law Enforcement

(S//SI)

[Redacted]

(U) Working Aids

(b)(3)-P.L. 86-36

(U//FOUO) The SID maintains [Redacted] on its web page for use by all NSA/CSS analysts. The E.O., NSA/CSS Regulation 10-30, DoD Regulation 5240.1-R, and USSID 18 are also available on-line. [Redacted]

SECURITY CLASSIFICATION

NSA STAFF PROCESSING FORM

TO DIRECTOR		EXREG CONTROL NUMBER 91747	KCC CONTROL NUMBER IG-10345-04	
THRU D/DIR		D SECRETARIAT		ACTION <input type="checkbox"/> APPROVAL <input checked="" type="checkbox"/> SIGNATURE <input type="checkbox"/> INFORMATION
SUBJECT (U//FOUO) Quarterly Report to the Intelligence Oversight Board on NSA Activities—Second Quarter FY04				EXREG SUSPENSE KCC SUSPENSE ELEMENT SUSPENSE
DISTRIBUTION JAN-MAR 04				

SUMMARY

PURPOSE: (U//FOUO) To forward to the Intelligence Oversight Board (IOB) of the President's Foreign Intelligence Advisory Board, via the Assistant to the Secretary of Defense for Intelligence Oversight (ATSD(IO)), NSA's quarterly report on its intelligence activities.

BACKGROUND: (U//FOUO) Executive Order 12333 and Executive Order 12863 require Intelligence Community agency heads and Intelligence Community General Counsels and Inspectors General, respectively, to report to the IOB on a quarterly basis concerning intelligence activities that they have reason to believe may be unlawful or contrary to Executive Order or Presidential Directive. The enclosed memorandum covers all reportable activities known to the Inspector General and General Counsel. Per PIOB letter of 6 August 1982, Agency heads are responsible for reporting separately any additional reportable activities known to them, unless the President has specifically instructed that the Board is not to be informed. The Director's signature signifies that no other activities that require reporting are known to him.

RECOMMENDATION: (U) Director sign the enclosed memorandum.

This document may be declassified and marked "UNCLASSIFIED//For Official Use Only" upon removal of enclosure(s)

Approved for Release by NSA on 06-01-2009, FOIA Case # 49107

(b) (3) - P.L. 86-36

COORDINATION/APPROVAL					
OFFICE	NAME AND DATE	SECURE PHONE	OFFICE	NAME AND DATE	SECURE PHONE
GC	Robert L. Deitz	35548s	D05	Deitz 6/8	3201
AGC(O)		3121s			
IG	Joel F. Bre	3544s			
D/IG		3544s			
AIC(IO)		3544s			
ORG. D11			PHONE (Secure) 963-2984		DATE PREPARED 3 June 2004
M 123-2			SECURITY CLASSIFICATION TOP SECRET//COMINT//NOFORN//X1		

~~TOP SECRET//COMINT//NOFORN//X1~~

NATIONAL SECURITY AGENCY
CENTRAL SECURITY SERVICE
FORT GEORGE G. MEADE, MARYLAND 20755-6000

9 June 2004

MEMORANDUM FOR THE CHAIRMAN, INTELLIGENCE OVERSIGHT BOARD

THRU: Assistant to the Secretary of Defense (Intelligence Oversight)

SUBJECT: (U//FOUO) Report to the Intelligence Oversight Board on NSA
Activities - INFORMATION MEMORANDUM

(U//FOUO) Except as previously reported to you or the President, or otherwise stated in the enclosure, we have no reason to believe that any intelligence activities of the National Security Agency during the quarter ending 31 March 2004, were unlawful or contrary to Executive Order or Presidential Directive, and thus required to be reported pursuant to Section 1.7.(d) of Executive Order 12333.

(U//FOUO) The Inspector General and the General Counsel continue to exercise oversight of Agency activities by means of inspections, surveys, training, review of directives and guidelines, and advice and counsel. These activities and other data requested by the Board or members of the staff of the Assistant to the Secretary of Defense (Intelligence Oversight) are described in the enclosure.

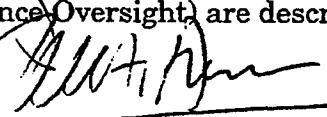

JOEL F. BRENNER
Inspector General



ROBERT L. DEITZ
General Counsel

(U//FOUO) I concur in the report of the Inspector General and the General Counsel and hereby make it our combined report.



MICHAEL V. HAYDEN
Lieutenant General, USAF
Director, NSA/Chief, CSS

Encl:
Quarterly Report with NSA/CSS Policy 1-23

This Memorandum is Unclassified
Upon Removal of Enclosure

DERIVED FROM: NSA/CSSM 123-2
DATED: 24 FEB 98
DECLASSIFY ON: X1

~~TOP SECRET//COMINT//NOFORN//X1~~

1. (U) INSPECTOR GENERAL ACTIVITIES

a. ~~(C//SI)~~ During this quarter, the Office of Inspector General (OIG) reviewed various intelligence activities of the National Security Agency/Central Security Service (NSA/CSS) to determine whether they were conducted in accordance with applicable statutes, Executive Orders (E.O.s), Attorney General procedures, and DoD and internal directives. With few exceptions, the issues presented were routine and indicated that the operating elements understand the restrictions on NSA/CSS activities.

b. ~~(S//SI)~~ The NSA OIG completed an inspection of the ^{(b)(3)-P.L. 86-36} [redacted] Division. The inspection found no intelligence oversight (I/O) shortcomings. The Division submits quarterly compliance reports to the Information Assurance Directorate. All employees participate in annual refresher training, which is tracked by division management.

c. ~~(TS//SI)~~ [redacted]

EO USC 403
P.L. 86-36

2. (U) GENERAL COUNSEL ACTIVITIES

~~(C//SI)~~ The NSA OGC reviewed various intelligence activities of the NSA/CSS to determine whether they were conducted in accordance with applicable statutes, E.O.s, Attorney General procedures, and DoD and internal directives. The OGC advised Agency elements on a number of questions, including the collection and dissemination of communications of or concerning U.S. persons; the reporting of possible violations of federal criminal law contained in SIGINT product; the testing of electronic equipment; and the applicability of the Foreign Intelligence Surveillance Act (FISA). With few exceptions, the issues presented were routine and indicated

DERIVED FROM: NSA/CSSM 123-2

DATED: 24 FEB 98

DECLASSIFY ON: X1

that the operating elements understand the restrictions on NSA/CSS activities. The OGC did not file any reports with the Intelligence Oversight Board during this quarter.

3. (U) SIGINT ACTIVITIES

a. (S//SI) [Redacted]

(b)(3)-P.L. 86-36

(1) (U) [Redacted]

(S//SI) [Redacted]

(b)(3)-P.L. 86-36

(b)(1)
(b)(3)-P.L. 86-36

[Redacted]

(S//SI) [Redacted]

(b)(3)-P.L. 86-36

[Redacted]

(2) (U) [Redacted]

(b)(3)-P.L. 86-36

a. (TS//SI) [Redacted]

[Redacted]

(b)(1)
(b)(3)-50 USC 403
(b)(3)-18 USC 798
(b)(3)-P.L. 86-36

b. (TS//SI) [Redacted]

[Redacted]

c. (TS//SI) [Redacted]

[Redacted]

~~TOP SECRET//COMINT//NOFORN//X1~~

~~(TS//SI//NF)~~

(b)(3)-P.L. 86-36
(b)(1)

(b)(3)-P.L. 86-36

Yes

b. (U//FOUO)

(1) (U)

~~(S//SI)~~

(b)(1)
(b)(3)-P.L. 86-36

(b)(3)-P.L. 86-36

(2) (U)

~~(S//SI)~~

~~(TS//SI)~~

(b)(3)-P.L. 86-36

(b)(1)
(b)(3)-P.L. 86-36

(b)(1)
(b)(3)-50 USC 403
(b)(3)-P.L. 86-36

~~TOP SECRET//COMINT//NOFORN//X1~~

~~TOP SECRET//COMINT//NOFORN//X1~~

[Redacted]

(b)(3)-P.L. 86-36

(3) (U)

[Redacted]

(b)(3)-P.L. 86-36

a. (S//SI)

[Redacted]

b. (S)

[Redacted]

[Redacted]

(b)(1)
(b)(3)-P.L. 86-36
(b)(3)-50 USC 403
(b)(3)-18 USC 798

c. (S)

[Redacted]

d. (S//SI)

[Redacted]

~~TOP SECRET//COMINT//NOFORN//X1~~

(b)(3)-P.L. 86-36

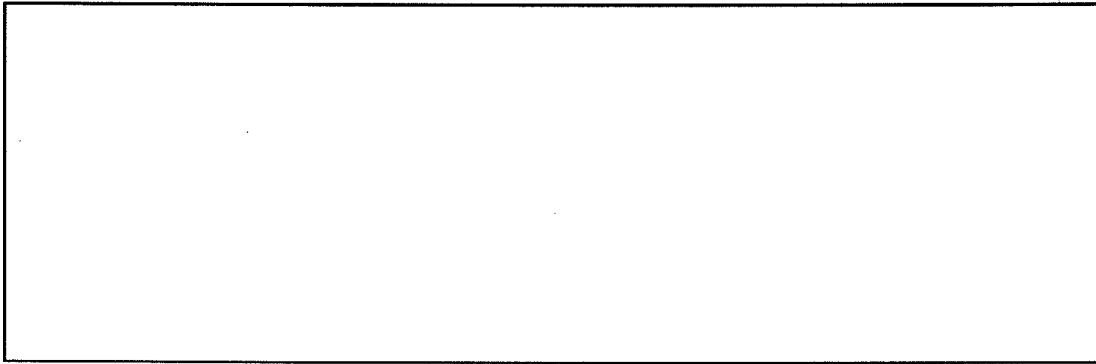

4. (U) OTHER ACTIVITIES

(U//FOUO)

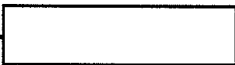

(b)(3)-P.L. 86-36

a. ~~(TS//SI//NF)~~

(b)(1)
(b)(3)-50 USC 403
(b)(3)-16 DSC 798
(b)(3)-P.L. 86-36

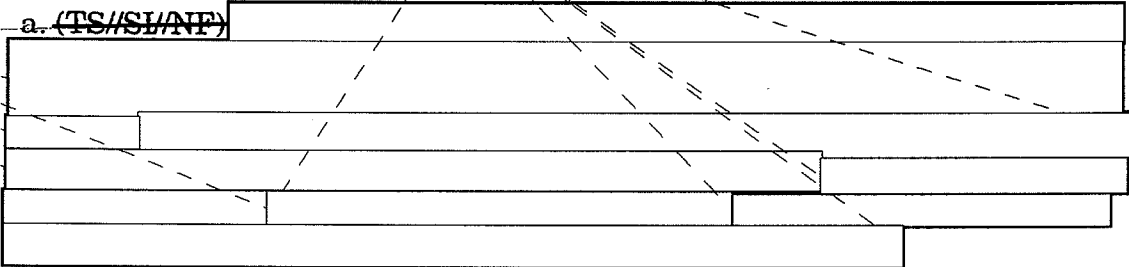

b. ~~(TS//SI//NF)~~

(b)(3)-P.L. 86-36

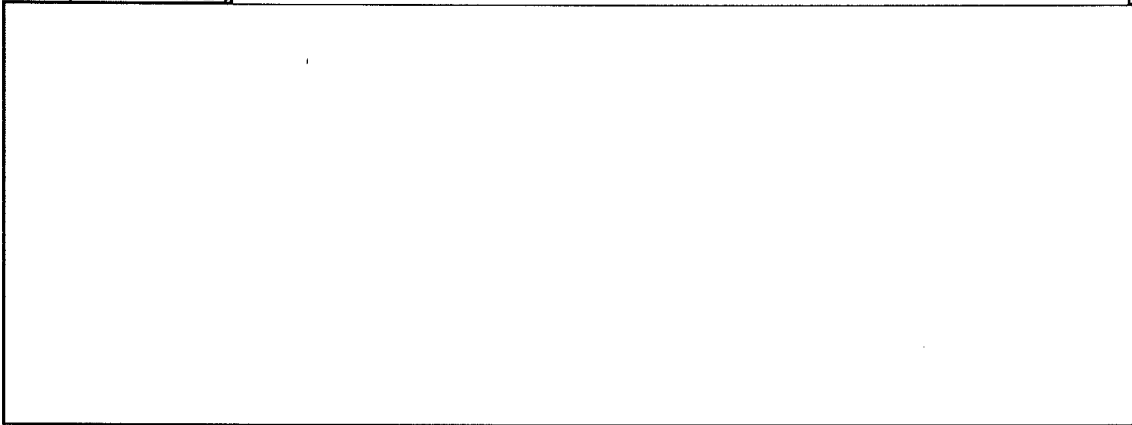

(U) Assistance to Law Enforcement

(b)(3)-P.L. 86-36

~~(S//SI)~~

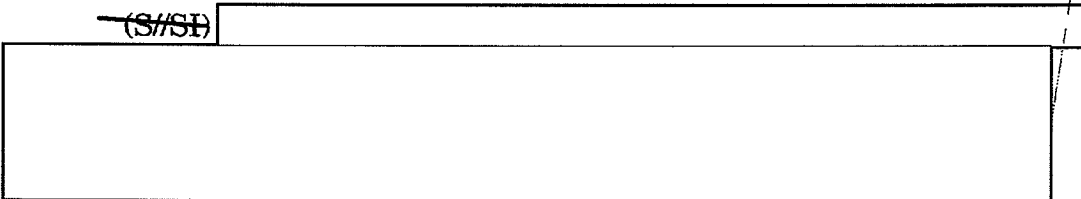

~~TOP SECRET//COMINT//NOFORN//XI~~

(U) Working Aids

(U//~~FOUO~~) The SID maintains [redacted] on its web page for use by all NSA/CSS analysts. The E.O., NSA/CSS Policy 1-23, DoD Regulation 5240.1-R, and USSID 18 are also available on-line. [redacted]

(b)(3)-P.L. 86-36

(b)(3)-P.L. 86-36

(U) Intelligence Oversight Training

a. (U//~~FOUO~~) In March 2004, SID implemented its new I/O training program, which allows employees to access the required documents and register their compliance on the web. The new program reminds employees that,

(U) "The primary document governing NSA's intelligence activities is Executive Order 12333. In addition, NSA employees are subject to DoD Regulation 5240.1-R . . . , which implement(s) the Executive Order. For SID employees, USSID 18 provides the SIGINT minimization procedures required by these documents and the Foreign Intelligence Surveillance Act. Finally, NSCID 6 defines SIGINT and prescribes the conduct of SIGINT activities."

b. (U//~~FOUO~~) In response to the December 2001 NSA OIG report, *Strategic Assessment of Intelligence Oversight*, Agency leadership revised NSA/CSS Directive 10-30, by including more detailed guidance about I/O training and quarterly reporting requirements. NSA issued the revised procedures as NSA/CSS Policy 1-23. A copy of the procedures is enclosed.

~~TOP SECRET//COMINT//NOFORN//XI~~

SECURITY CLASSIFICATION

NSA STAFF PROCESSING FORM

TO DIRECTOR		EXREG CONTROL NUMBER 92992	KCC CONTROL NUMBER IG-10401-04
THRU D/DIR D SECRETARIAT		ACTION <input type="checkbox"/> APPROVAL <input checked="" type="checkbox"/> SIGNATURE <input type="checkbox"/> INFORMATION	EXREG SUSPENSE KCC SUSPENSE ELEMENT SUSPENSE
SUBJECT (U//FOUO) Quarterly Report to the Intelligence Oversight Board on NSA Activities—Third Quarter FY04			
DISTRIBUTION			

SUMMARY

PURPOSE: (U//FOUO) To forward to the Intelligence Oversight Board (IOB) of the President's Foreign Intelligence Advisory Board, via the Assistant to the Secretary of Defense for Intelligence Oversight (ATSD(IO)), NSA's quarterly report on its intelligence activities.

BACKGROUND: (U//FOUO) Executive Order 12333 and Executive Order 12863 require Intelligence Community agency heads and Intelligence Community General Counsels and Inspectors General, respectively, to report to the IOB on a quarterly basis concerning intelligence activities that they have reason to believe may be unlawful or contrary to Executive Order or Presidential Directive. The enclosed memorandum covers all reportable activities known to the Inspector General and General Counsel. Per PIOB letter of 6 August 1982, Agency heads are responsible for reporting separately any additional reportable activities known to them, unless the President has specifically instructed that the Board is not to be informed. The Director's signature signifies that no other activities that require reporting are known to him.

RECOMMENDATION: (U) Director sign the enclosed memorandum.

This document may be declassified and marked "UNCLASSIFIED//For Official Use Only" upon removal of enclosure(s)

Approved for Release by NSA on 06-01-2009, FOIA Case # 49107

COORDINATION/APPROVAL

OFFICE	NAME AND DATE	SECURE PHONE	OFFICE	NAME AND DATE	SECURE PHONE
GC	Robert L. Deitz	5548s	D05	9/10	963-3520
AGC(O)		21s			
IG	Joel F. Bren	3544s		(b) (3) - P.L. 86-36	
D/IG		3544s			
AIG(IO)		3544			

ORG D11	PHONE (Secure) 963-2984	DATE PREPARED 30 August 2004
-------------------	-----------------------------------	--

~~TOP SECRET//COMINT//NOFORN//X1~~

NATIONAL SECURITY AGENCY
CENTRAL SECURITY SERVICE
FORT GEORGE G. MEADE, MARYLAND 20755-6000

13 September 2004

MEMORANDUM FOR THE CHAIRMAN, INTELLIGENCE OVERSIGHT BOARD

THRU: Assistant to the Secretary of Defense (Intelligence Oversight)

SUBJECT: (U//~~FOUO~~) Report to the Intelligence Oversight Board on NSA
Activities - INFORMATION MEMORANDUM

(U//~~FOUO~~) Except as previously reported to you or the President, or otherwise stated in the enclosure, we have no reason to believe that any intelligence activities of the National Security Agency during the quarter ending 30 June 2004 were unlawful or contrary to Executive Order or Presidential Directive, and thus required to be reported pursuant to Section 1.7.(d) of Executive Order 12333.

(U//~~FOUO~~) The Inspector General and the General Counsel continue to exercise oversight of Agency activities by means of inspections, surveys, training, review of directives and guidelines, and advice and counsel. These activities and other data requested by the Board or members of the staff of the Assistant to the Secretary of Defense (Intelligence Oversight) are described in the enclosure.

JOEL F. BRENNER
Inspector General

ROBERT L. DEITZ
General Counsel

(U//~~FOUO~~) I concur in the report of the Inspector General and the General Counsel and hereby make it our combined report.

MICHAEL V. HAYDEN
Lieutenant General, USAF
Director, NSA/Chief, CSS

Encl:
Quarterly Report

This Document May Be Declassified and Marked
"UNCLASSIFIED//~~FOR OFFICIAL USE ONLY~~"
upon removal of enclosure(s).

DERIVED FROM: NSA/CSSM 123-2
Dated: 24 February 1998
Declassify on: X1

~~TOP SECRET//COMINT//NOFORN//X1~~

1. (U) INSPECTOR GENERAL ACTIVITIES

a. ~~(C//SI)~~ During this quarter, the Office of Inspector General (OIG) reviewed various intelligence activities of the National Security Agency/Central Security Service (NSA/CSS) to determine whether they were conducted in accordance with applicable statutes, Executive Orders (E.O.s), Attorney General procedures, and DoD and internal directives. With few exceptions, the issues presented were routine and indicated that the operating elements understand the restrictions on NSA/CSS activities.

b. ~~(S//SI)~~ [Redacted]

(b)(3)-P.L. 86-36

[Redacted] Corrective action has been directed and will be monitored through completion.

c. ~~(S//SI//NF)~~ [Redacted]

(b)(3)-P.L. 86-36

~~(S//SI//NF)~~ [Redacted]

(b)(1)
(b)(3)-50 USC 403
(b)(3)-P.L. 86-36

d. ~~(U//FOUO)~~ Along with inspectors from [Redacted] the NSA OIG completed a joint inspection of [Redacted]

(b)(3)-P.L. 86-36

[Redacted] The joint inspection report notes that the site's intelligence oversight program is weak in training and documentation procedures. The inspection team noted that annual refresher training, which is accomplished by online posting of required reading material, is inconsistent and lacks documentation. A revisit to [Redacted] by the Joint Inspectors General will be scheduled for next year.

2. (U) GENERAL COUNSEL ACTIVITIES

~~(S//SI)~~ The NSA Office of General Counsel (OGC) reviewed various intelligence activities of the NSA/CSS to determine whether they were conducted in accordance with applicable statutes, E.O.s, Attorney General procedures, and DoD and internal directives. The OGC advised Agency elements on a number of questions, including the collection and dissemination of communications of or concerning U.S. persons; the reporting of possible violations of federal criminal law contained in SIGINT product; the testing of electronic equipment; and the applicability of the Foreign Intelligence Surveillance Act (FISA). With few exceptions, the issues presented were routine and indicated that the operating elements understand the restrictions on NSA/CSS activities. The OGC did not file any reports with the Intelligence Oversight Board during this quarter.

3. (U) SIGINT ACTIVITIES

a. ~~(S//SI)~~

[Redacted]

(1) (U)

[Redacted]

a. ~~(S//SI)~~

[Redacted]

[Redacted]

[Redacted]

[Redacted]

(b)(3)-P.L. 86-36

b. ~~(S//SI)~~

[Redacted]

[Redacted]

(b)(1)
(b)(3)-P.L. 86-36

(2) (U)

[Redacted]

a. ~~(S//SI)~~

[Redacted]

[Redacted]

[Redacted]

[Redacted]

b. ~~(TS//SI)~~

[Redacted]

[Redacted]

[Redacted]

[Redacted]

[Redacted]

[Redacted]

[Redacted]

[Redacted]

(b)(3)-P.L. 86-36

(b)(1)
(b)(3)-50 USC 403
(b)(3)-18 USC 798
(b)(3)-P.L. 86-36

~~TOP SECRET//COMINT//NOFORN//XI~~

[Redacted]

50 USC 403
58 USC 798
P.L. 86-36

c. ~~(TS//SI)~~

[Redacted]

d. ~~(S//SI//NF)~~

[Redacted]

b. (U//FOUO)

[Redacted]

(b)(3)-P.L. 86-36

(1) (U)

[Redacted]

~~(S//SI)~~

[Redacted]

(b)(1)
(b)(3)-P.L. 86-36

[Redacted]

~~TOP SECRET//COMINT//NOFORN//XI~~

~~TOP SECRET//COMINT//NOFORN//X1~~

(b)(3)-P.L. 86-36

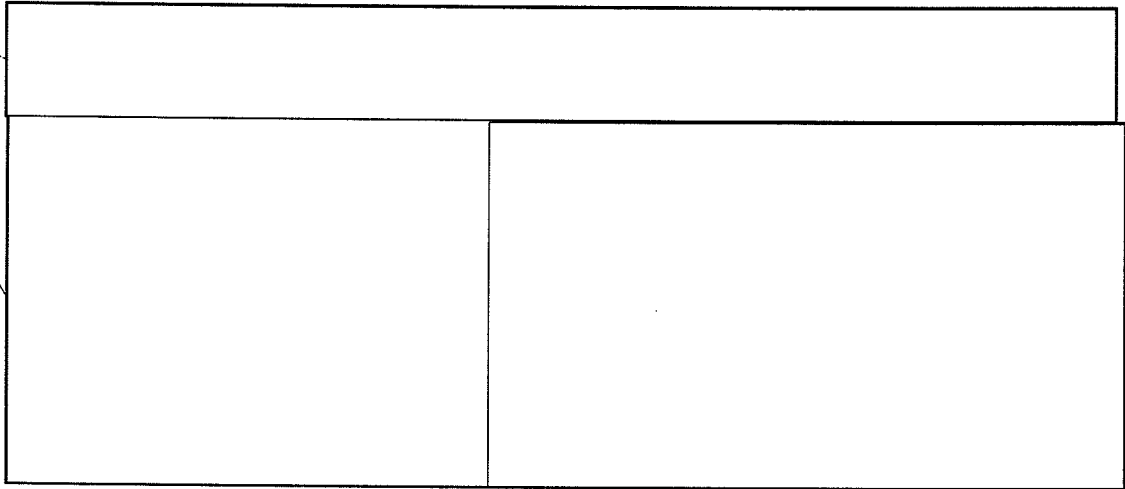

(2) (U)

(b)(3)-P.L. 86-36

(b)(1)
(b)(3)-P.L. 86-36

(b)(1)
(b)(3)-50 USC 403
(b)(3)-18 USC 798
(b)(3)-P.L. 86-36

a. (TS//SI)

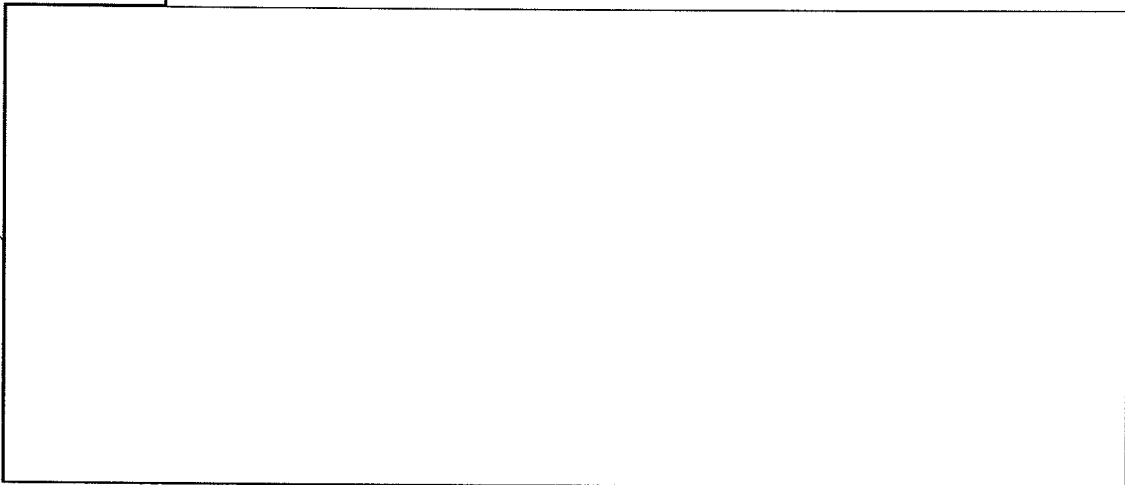

b. (S//SI)

(b)(3)-P.L. 86-36

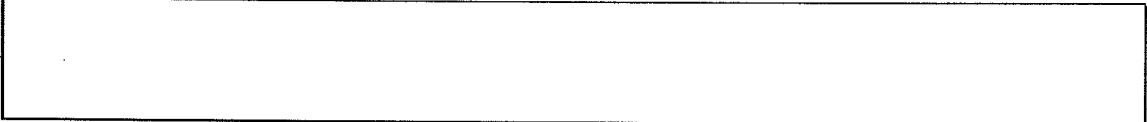

(b)(1)
(b)(3)-50 USC 403
(b)(3)-P.L. 86-36

c. (TS//SI)

(b)(3)-P.L. 86-36

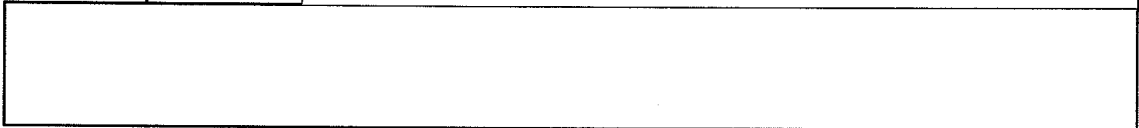

(b)(3)-P.L. 86-36

(b)(3)-P.L. 86-36

(3) (U)

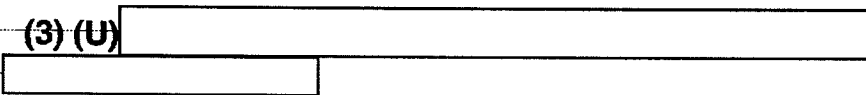

a. (TS//SI)

(b)(3)-P.L. 86-36



~~TOP SECRET//COMINT//NOFORN//X1~~

~~TOP SECRET//COMINT//NOFORN//XI~~

(b)(1)
(b)(3)-P.L. 86-36

[Redacted]

(b)(3)-P.L. 86-36

(b)(3)-P.L. 86-36

b. (TS//SI) [Redacted]

(b)(3)-P.L. 86-36

c. (S//SI) [Redacted]

4. (U) OTHER ACTIVITIES

(U//FOUO) [Redacted]

(b)(3)-P.L. 86-36

a. (TS//SI) [Redacted]

(b)(3)-P.L. 86-36

(b)(3)-P.L. 86-36
(b)(1)
(b)(3)-50 USC 403
(b)(3)-18 USC 798

[Redacted]

~~TOP SECRET//COMINT//NOFORN//XI~~

(b)(1)
(b)(3)-50 USC 403
(b)(3)-P.L. 86-36
(b)(3)-18 USC 798

~~TOP SECRET//COMINT//NOFORN//X1~~

b. ~~(TS//SI//NF)~~

[Redacted]

~~(TS//SI//NF)~~

[Redacted]

(b)(3)-P.L. 86-36

[Redacted]

(b)(1)
(b)(3)-50 USC 403
(b)(3)-P.L. 86-36
(b)(3)-18 USC 798

(U) Assistance to Law Enforcement

~~(S//SI)~~

[Redacted]

(b)(3)-P.L. 86-36

(U) Working Aids

(b)(3)-P.L. 86-36

(U//FOUO) The SID maintains [Redacted] on its web page for use by all NSA/CSS analysts. The E.O., NSA/CSS Policy 1-23, DoD Regulation 5240.1-R, and USSID 18 are also available on-line. [Redacted]

(U) Intelligence Oversight Training

(U//FOUO) During this quarter an intelligence oversight specialist from the SID Office of Oversight and Compliance provided on-site training to military, civilian, and contractor personnel [Redacted]

(b)(3)-P.L. 86-36

~~TOP SECRET//COMINT//NOFORN//X1~~

~~TOP SECRET//COMINT//NOFORN//X1~~

[Redacted]
[Redacted] The training included Intelligence
Oversight, E.O. 12333, USSID 9 and USSID 18, DOD Regulation 5240.1-R,
NSA/CSS Policy 1-23, [Redacted]
[Redacted]

(b)(3)-P.L. 86-36
(b)(1)
(b)(3)-50 USC 403

~~TOP SECRET//COMINT//NOFORN//X1~~

[Redacted]

(CIV-NSA) D11

(b)(3)-P.L. 86-36

From: [Redacted]
Sent: [Redacted]
To: [Redacted]
Subject: (U) PLEASE READ

[Redacted]@nsa
Tuesday, August 24, 2004 3:26 PM
[Redacted]@nsa
(U) PLEASE READ

(b)(1)
(b)(3)-50 USC 403
(b)(3)-P.L. 86-36

(b)(3)-P.L. 86-36

Classification: ~~SECRET//COMINT//NOFORN//X1~~

DR ✓ FM: Class. Guide 356-01
DATED: 3 July 2001
DECLON: X1

All, please read the note I received from Lt. Gen. Hayden [Redacted] this morning and then read [Redacted] and my comments below it.

(b)(1)
(b)(3)-50 USC 403
(b)(3)-P.L. 86-36

----- Forwarded by [Redacted] HQS on 08/24/2004 12:59 PM -----

(b)(3)-P.L. 86-36

"Hayden, Michael V. (MIL-USAF) D" <mvhayde@nsa> on 08/24/2004 08:33:47 AM

Please respond to mvhayde@nsa

[Redacted]

(b)(1)
(b)(3)-50 USC 403
(b)(3)-P.L. 86-36

[Redacted]

(b)(3)-P.L. 86-36

(b)(3)-P.L. 86-36

Classification: ~~SECRET//COMINT//NOFORN//X1~~

[Redacted]

The enclosed message was coordinated with [Redacted] Gen Hayden. It is my understanding that you will disseminate on their behalf. Please let me know if you have any questions. Thanks!

(b)(1)
(b)(3)-50 USC 403
(b)(3)-P.L. 86-36

Marjorie

(b)(3)-P.L. 86-36

[Redacted]

Civilian Assistant to the Director
963-3111

>

(S//SI//NF) [Redacted]

(b)(1)
(b)(3)-50 USC 403
(b)(3)-P.L. 86-36

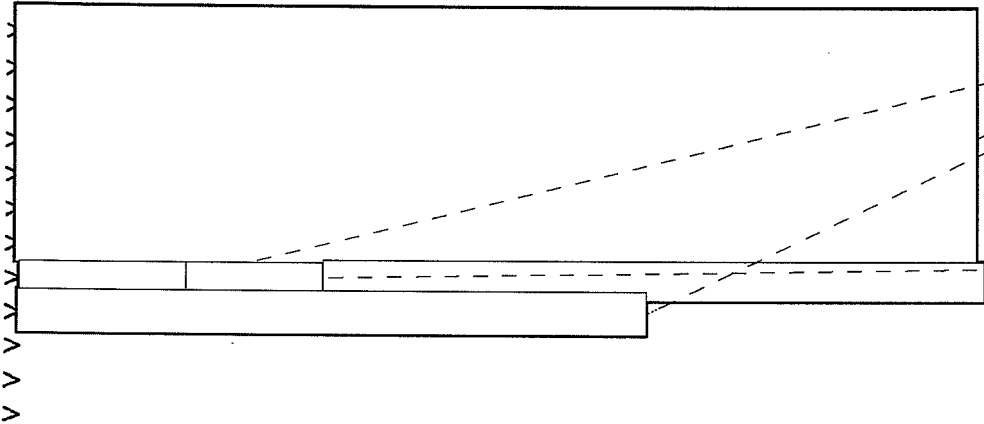

(b)(3)-P.L. 86-36

(b)(1)
(b)(3)-50 USC 403
(b)(3)-P.L. 86-36

DRV FM: NSA/CSS Manual 123-2

Dated: 24 Feb 98

DECL ON: X1

Classification: ~~SECRET//COMINT//NOFORN//X1~~

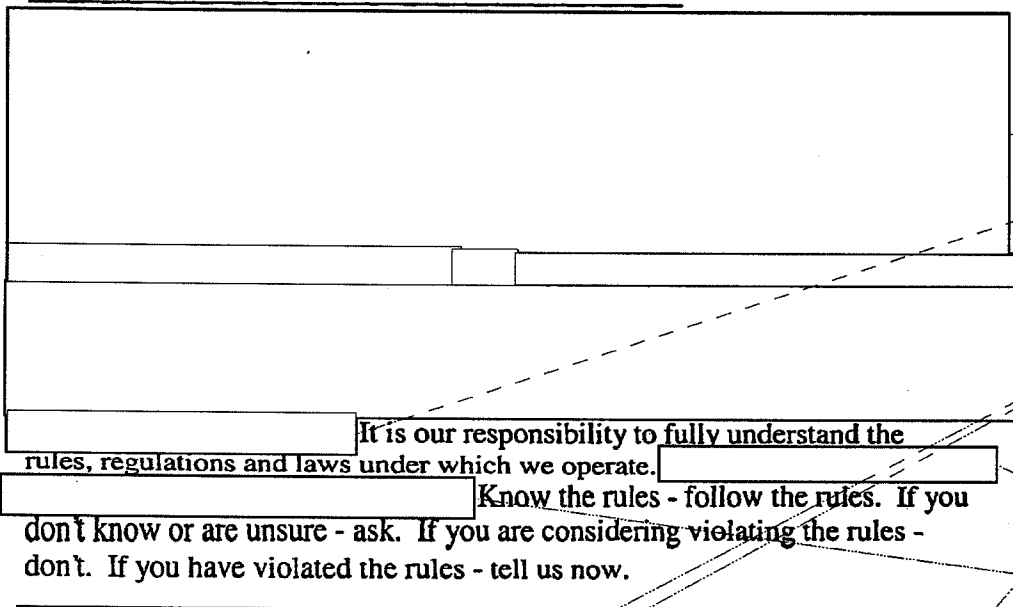

(b)(3)-P.L. 86-36

(b)(3)-P.L. 86-36

(b)(1)
(b)(3)-50 USC 403
(b)(3)-P.L. 86-36

It is our responsibility to fully understand the rules, regulations and laws under which we operate. Know the rules - follow the rules. If you don't know or are unsure - ask. If you are considering violating the rules - don't. If you have violated the rules - tell us now.

(b)(3)-P.L. 86-36

(b)(1)
(b)(3)-50 USC 403
(b)(3)-P.L. 86-36

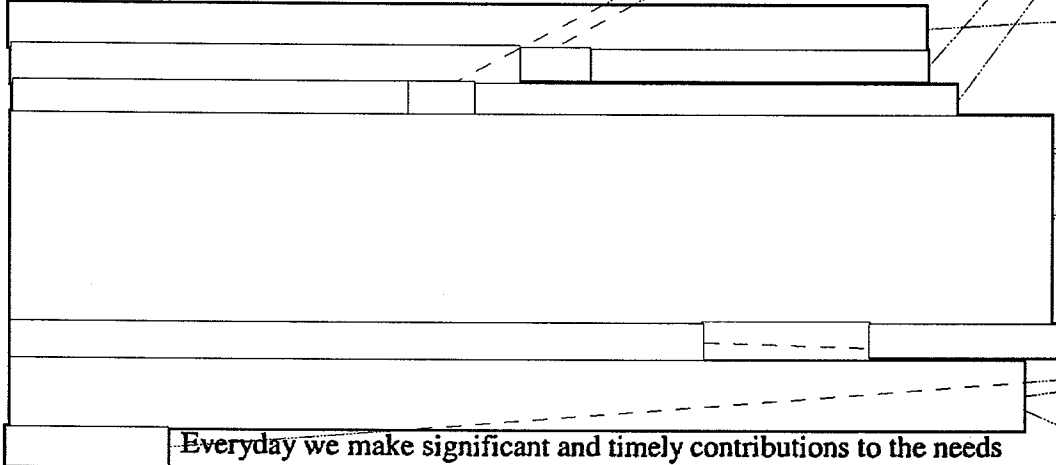

(b)(3)-P.L. 86-36

Everyday we make significant and timely contributions to the needs

(b)(1)
(b)(3)-50 USC 403
(b)(3)-P.L. 86-36

of our country under often very difficult conditions. Everyday we make thousands of successful decisions that effect the security and safety of our country. Everyday [redacted] demonstrate integrity in our actions and are conscientious in doing our job within the parameters set for us. Everyday you make me proud to be a member of this organization and be given the opportunity to lead you. [redacted]

(b)(1)
(b)(3)-50 USC 403
(b)(3)-P.L. 86-36

[redacted] I ask for your increased attention to the rules, regulations and laws that we must follow. It is important for each of us to always conduct ourselves in a manner that is a model for others and beyond reproach.

(b)(3)-P.L. 86-36

If you have questions or comments, please contact [redacted] or me.

Classification: ~~SECRET//COMINT//NOFORN//~~

SECURITY CLASSIFICATION

Approved for Release by NSA on 06-01-2009, FOIA Case # 49107

NSA STAFF PROCESSING FORM

TO DIRECTOR	EXREG CONTROL NUMBER 94060	KCC CONTROL NUMBER IG-10435-04
THRU D/DIR	ACTION <input type="checkbox"/> APPROVAL <input checked="" type="checkbox"/> SIGNATURE <input type="checkbox"/> INFORMATION	EXREG SUSPENSE
SUBJECT (U//FOUO) Quarterly Report to the Intelligence Oversight Board on NSA Activities—Fourth Quarter FY04		KCC SUSPENSE
DISTRIBUTION OGC		ELEMENT SUSPENSE

SUMMARY

PURPOSE: (U//FOUO) To forward to the Intelligence Oversight Board (IOB) of the President's Foreign Intelligence Advisory Board, via the Assistant to the Secretary of Defense for Intelligence Oversight (ATSD(IO)), NSA's quarterly report on its intelligence activities.

BACKGROUND: (U//FOUO) Executive Order 12333 and Executive Order 12863 require Intelligence Community agency heads and Intelligence Community General Counsels and Inspectors General, respectively, to report to the IOB on a quarterly basis concerning intelligence activities that they have reason to believe may be unlawful or contrary to Executive Order or Presidential Directive. The enclosed memorandum covers all reportable activities known to the Inspector General and General Counsel. Per PIOB letter of 6 August 1982, Agency heads are responsible for reporting separately any additional reportable activities known to them, unless the President has specifically instructed that the Board is not to be informed. The Director's signature signifies that no other activities that require reporting are known to him.

RECOMMENDATION: (U) Director sign the enclosed memoranda

Bob-

This document may be declassified and marked "UNCLASSIFIED//~~For Official Use Only~~" upon removal of enclosure(s)

(b)(5)

COORDINATION/APPROVAL

OFFICE	NAME AND DATE	SECURE PHONE	OFFICE	NAME AND DATE	SECURE PHONE
GC	Robert L. [redacted]	5548s	205	[redacted]	11/23 963-3201
AGC(O)	[redacted]	3121s			
IG	Joel F. Brenner	3544s			
D/IG	[redacted]	3544s			(b)(3) P.L. 86-36
AIG(IO)	[redacted]	3544			

ORIGINATOR

[redacted]

ORG D11	PHONE (Secure) 963-2984	DATE PREPARED 09 November 2004
-------------------	-----------------------------------	--



NATIONAL SECURITY AGENCY
 CENTRAL SECURITY SERVICE
 FORT GEORGE G. MEADE, MARYLAND 20755-6000

29 November 2004

MEMORANDUM FOR THE CHAIRMAN, INTELLIGENCE OVERSIGHT BOARD

THRU: Assistant to the Secretary of Defense (Intelligence Oversight)

SUBJECT: (U//~~FOUO~~) Report to the Intelligence Oversight Board on NSA
 Activities - INFORMATION MEMORANDUM

(U//~~FOUO~~) Except as previously reported to you or the President, or otherwise stated in the enclosure, we have no reason to believe that any intelligence activities of the National Security Agency during the quarter ending 30 September 2004 were unlawful or contrary to Executive Order or Presidential Directive, and thus required to be reported pursuant to Section 1.7.(d) of Executive Order 12333.

(U//~~FOUO~~) The Inspector General and the General Counsel continue to exercise oversight of Agency activities by means of inspections, surveys, training, review of directives and guidelines, and advice and counsel. These activities and other data requested by the Board or members of the staff of the Assistant to the Secretary of Defense (Intelligence Oversight) are described in the enclosure.

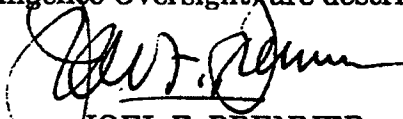
 JOEL F. BRENNER
 Inspector General

 ROBERT L. DEITZ
 General Counsel

(U//~~FOUO~~) I concur in the report of the Inspector General and the General Counsel and hereby make it our combined report.

 MICHAEL V. HAYDEN
 Lieutenant General, USAF
 Director, NSA/Chief, CSS

Encl:
 Quarterly Report

This Document May Be Declassified and Marked
 "UNCLASSIFIED//FOR OFFICIAL USE ONLY"
 upon removal of enclosure(s).

DERIVED FROM: NSA/CSSM 123-2
 Dated: 24 February 1998
 Declassify on: X1

1. (U) INSPECTOR GENERAL ACTIVITIES

a. ~~(C//SI)~~ During this quarter, the Office of Inspector General (OIG) reviewed various intelligence activities of the National Security Agency/Central Security Service (NSA/CSS) to determine whether they were conducted in accordance with applicable statutes, Executive Orders (EO), Attorney General procedures, and Department of Defense (DoD) and internal directives. With few exceptions, the issues presented were routine and indicated that the operating elements understand the restrictions on NSA/CSS activities.

b. ~~(S)~~ The OIG conducted a review of NSA's management of electronic surveillance activities carried out under the Foreign Intelligence Surveillance Act (FISA) of 1978.

different from inquiry

*7uP
ST-03-0008*

[Redacted]

(b)(3)-P.L. 86-36

The OIG recommended improvements in the written guidance that defines authorities and assigns roles and responsibilities, step-by-step instructions to guide FISA process participants, the need for tailored training on FISA operational aspects, and meaningful metrics to gauge the efficiency of the process. NSA management has agreed to implement all recommendations.

c. ~~(U//FOUO)~~ The NSA OIG, with

*7uP
STOA
INSP*

[Redacted]

A program strength was that [redacted] had an embedded requirements manager who assessed IO implications of all EO 12333-related tasking. Employee knowledge levels were satisfactory and there were no violations of applicable laws, executive order, regulations, or policies noted, but the inspectors identified weaknesses in program management documentation and training and reporting compliance methods. The NSA OIG has tasked [redacted] to develop and document standard operating procedures for the IO program and to report IO activities quarterly to the NSA OIG. The NSA OIG will track the action through completion.

(b)(3)-P.L. 86-36

d. ~~(C//REL)~~ Along with inspectors from the

*7uP
10004
INSP*

[Redacted] the NSA OIG completed

the joint inspection of [redacted]. The inspection report noted that the site's intelligence oversight program manager is visible and is actively involved in training and operations. Comprehension of initial and refresher IO training is measured through web-based testing.

(b)(3)-P.L. 86-36

(b)(1)
(b)(3)-50 USC 403
(b)(3)-P.L. 86-36

(b)(3)-P.L. 86-36

[Redacted]

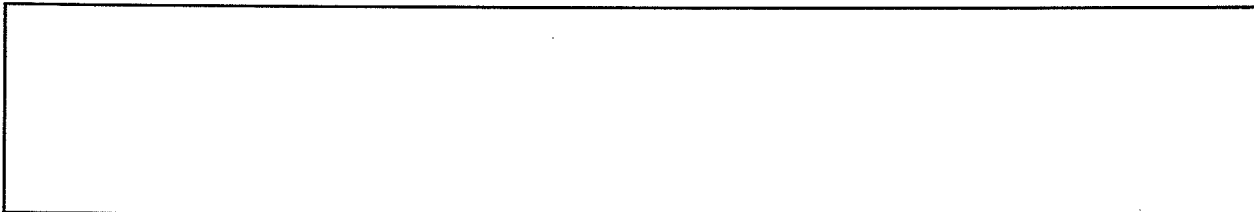

P.L. 86-36

2. (U) GENERAL COUNSEL ACTIVITIES

~~(C//SI)~~ The NSA Office of General Counsel (OGC) reviewed various intelligence activities of the NSA/CSS to determine whether they were conducted in accordance with applicable statutes, EO, Attorney General (AG) procedures, and DoD and internal directives. The OGC advised Agency elements on a number of questions, including the collection and dissemination of communications of or concerning U.S. persons (USP); the reporting of possible violations of federal criminal law contained in SIGINT product; the testing of electronic equipment; and the applicability of the FISA. With few exceptions, the issues presented were routine and indicated that the operating elements understand the restrictions on NSA/CSS activities. The OGC did not file any reports with the Intelligence Oversight Board during this quarter.

3. (U) SIGINT ACTIVITIES

a. ~~(S//SI)~~ [redacted]

(1) (U) [redacted]

a. ~~(S//SI)~~ [redacted]

b. ~~(S//SI)~~ [redacted]

(2) (U) [redacted]

a. ~~(S//SI)~~ [redacted]

b. ~~(S//SI//NF)~~ [redacted]

(b)(3)-P.L. 86-36

(b)(1)
(b)(3)-P.L. 86-36

(b)(3)-P.L. 86-36

(b)(1)
(b)(3)-50 USC 403
(b)(3)-18 USC 798
(b)(3)-P.L. 86-36

(b)(3)-P.L. 86-36

~~TOP SECRET//COMINT//NOFORN//X1~~

[Redacted]

(b)(3)-P.L. 86-36

b. (U//FOUO)

[Redacted]

(b)(3)-P.L. 86-36

(b)(1)

(1) (U)

[Redacted]

(b)(3)-P.L. 86-36

(S//SI)

[Redacted]

-P.L. 86-36

[Redacted]

.L. 86-36

[Redacted]

[Redacted]

[Redacted]

(b)(3)-P.L. 86

(2) (U)

[Redacted]

(b)(3)-P.L. 86-36

a. (S//SI)

[Redacted]

[Redacted]

b. (TS//SI)

[Redacted]

(b)(3)-P.L. 86-36

[Redacted]

(b)(1)
(b)(3)-50 USC 403
(b)(3)-P.L. 86-36

~~TOP SECRET//COMINT//NOFORN//X1~~

~~TOP SECRET//COMINT//NOFORN//X1~~

(3) (U) [Redacted] (b)(3)-P.L. 86-36

~~(S//SI)~~ [Redacted]

4. (U) Other Activities

(b)(3)-P.L. 86-36

a. (U//FOUO) [Redacted]

~~TS//SI~~ [Redacted]

(b)(1)
(b)(3)-50 USC 403
(b)(3)-18 USC 798
(b)(3)-P.L. 86-36

(b)(3)-P.L. 86-36

b. (U) Assistance to Law Enforcement

~~(S//SI)~~ [Redacted]

(b)(3)-P.L. 86-36

~~TOP SECRET//COMINT//NOFORN//X1~~

~~TOP SECRET//COMINT//NOFORN//X1~~

c. (U) Working Aids

(U//FOUO) The SID Office of Oversight and Compliance maintains

(b)(3)-P.L. 88-36

on its web page
for use by the NSA/CSS Enterprise. The E.O., NSA/CSS Policy Number 1-23, DoD
Regulation 5240.1-R, and USSID 18 are also available on-line.

~~TOP SECRET//COMINT//NOFORN//X1~~

SECURITY CLASSIFICATION

NSA STAFF PROCESSING FORM

TO DIRECTOR		EXREG CONTROL NUMBER 14174	KCC CONTROL NUMBER IG-10464-05
THRU D/DIR <i>[Signature]</i> D SECRETARIAT		ACTION <input type="checkbox"/> APPROVAL <input checked="" type="checkbox"/> SIGNATURE <input type="checkbox"/> INFORMATION	EXREG SUSPENSE
SUBJECT (U//FOUO) Quarterly Report to the Intelligence Oversight Board on NSA Activities			KCC-SUSPENSE
DISTRIBUTION		ELEMENT SUSPENSE	

SUMMARY

PURPOSE: (U//FOUO) To forward to the Intelligence Oversight Board (IOB) of the President's Foreign Intelligence Advisory Board, via the Assistant to the Secretary of Defense for Intelligence Oversight (ATSD(IO)), NSA's quarterly report on its intelligence activities.

BACKGROUND: (U//FOUO) Executive Order 12333 and Executive Order 12863 require Intelligence Community agency heads and Intelligence Community General Counsels and Inspectors General, respectively, to report to the IOB on a quarterly basis concerning intelligence activities that they have reason to believe may be unlawful or contrary to Executive Order or Presidential Directive. The enclosed memorandum covers all reportable activities known to the Inspector General and General Counsel. Per PIOB letter of 6 August 1982, Agency heads are responsible for reporting separately any additional reportable activities known to them, unless the President has specifically instructed that the Board is not to be informed. The Director's signature signifies that no other activities that require reporting are known to him.

RECOMMENDATION: (U) Director sign the enclosed memorandum.

This document may be declassified and marked "UNCLASSIFIED//For Official Use Only" upon removal of enclosure(s)

Approved for Release by NSA on 06-01-2009, FOIA Case # 49107

COORDINATION/APPROVAL					
OFFICE	NAME AND DATE	SECURE PHONE	OFFICE	NAME AND DATE	SECURE PHONE
GC	<i>[Signature]</i> Robert L. Deitz	5548s	DOS	3/10	902 320.
AGC(O)		3121s			
IG	Joel F. Bren	3544s			
D/IG	<i>[Signature]</i>	3544s		(b) (3) P.L. 86-36	
		3544s			
ORG. D11			PHONE (Secure) 963-2984	DATE PREPARED 1 March 2005	

~~TOP SECRET//COMINT//ORCON, NOFORN//X1~~

NATIONAL SECURITY AGENCY
CENTRAL SECURITY SERVICE
FORT GEORGE G. MEADE, MARYLAND 20755-6000

1QFY05

14 March 2005

MEMORANDUM FOR THE CHAIRMAN, INTELLIGENCE OVERSIGHT BOARD

THRU: Assistant to the Secretary of Defense (Intelligence Oversight)

SUBJECT: (U//~~FOUO~~) Report to the Intelligence Oversight Board on NSA
Activities - INFORMATION MEMORANDUM

(U//~~FOUO~~) Except as previously reported to you or the President, or otherwise stated in the enclosure, we have no reason to believe that any intelligence activities of the National Security Agency during the quarter ending 31 December 2004, were unlawful or contrary to Executive Order or Presidential Directive, and thus required to be reported pursuant to Section 1.7.(d) of Executive Order 12333.

(U//~~FOUO~~) The Inspector General and the General Counsel continue to exercise oversight of Agency activities by means of inspections, surveys, training, review of directives and guidelines, and advice and counsel. These activities and other data requested by the Board or members of the staff of the Assistant to the Secretary of Defense (Intelligence Oversight) are described in the enclosure.

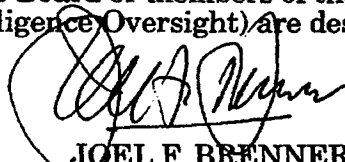
JOEL F. BRENNER
Inspector General

ROBERT L. DEITZ
General Counsel

(U//~~FOUO~~) I concur in the report of the Inspector General and the General Counsel and hereby make it our combined report.

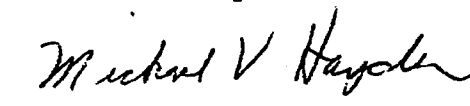
MICHAEL V. HAYDEN
Lieutenant General, USAF
Director, NSA/Chief, CSS

Encl:

Quarterly Report with NSA/CSS Policy 1-23

This Memorandum is Unclassified
Upon Removal of Enclosure

DERIVED FROM: NSA/CSSM 123-2
DATED: 24 FEB 98
DECLASSIFY ON: X1

~~TOP SECRET//COMINT//ORCON, NOFORN//X1~~

1. (U) INSPECTOR GENERAL ACTIVITIES

a. ~~(C//SI)~~ During this quarter, the Office of Inspector General (OIG) reviewed various intelligence activities of the National Security Agency/Central Security Service (NSA/CSS) to determine whether they were conducted in accordance with applicable statutes, Executive Orders (EO), Attorney General procedures, and Department of Defense (DoD) and internal directives. With few exceptions, the issues presented were routine and indicated that the operating elements understand the restrictions on NSA/CSS activities.

b. ~~(S)~~ As reported in the first quarter and amplified in the third quarter fiscal year 2004 (reports dated 17 March and 13 September 2004, respectively), an inquiry into [redacted] resulted in directed action to correct shortcomings [redacted]

(b)(3)-P.L. 86-36

741P
ST-04-0014

[redacted]
[redacted] clearly defined roles and responsibilities
[redacted]

have been implemented. We will continue to track the remaining recommendation for supplemental tailored initial and refresher training for all personnel involved in the collection process.

2. (U) GENERAL COUNSEL ACTIVITIES

~~(C//SI)~~ The NSA Office of General Counsel (OGC) reviewed various intelligence activities of the NSA/CSS to determine whether they were conducted in accordance with applicable statutes, EO, AG procedures, and DoD and internal directives. The OGC advised Agency elements on a number of questions, including the collection and dissemination of communications of or concerning U.S. persons (USP); the reporting of possible violations of federal criminal law contained in SIGINT product; the testing of electronic equipment; and the applicability of the FISA. With few exceptions, the issues presented were routine and indicated that the operating elements understand the restrictions on NSA/CSS activities. The OGC did not file any reports with the Intelligence Oversight Board during this quarter.

DERIVED FROM: NSA/CSSM123-2
DATED: 24 FEB 98
DECLASSIFY ON: X1

3. (U) SIGINT ACTIVITIES

a. (S//SI) [redacted]

(1) (U) [redacted]

(b)(3)-P.L. 86-36

a. (S//SI) [redacted]

(b)(1)
(b)(3)-P.L. 86-36

b. (S//SI) [redacted]

c. (TS//SI) [redacted]

(b)(1)
(b)(3)-50 USC 403
(b)(3)-18 USC 788
(b)(3)-P.L. 86-36

(2) (U) [redacted]

(b)(3)-P.L. 86-36

a. (S//SI//NF) [redacted]

(b)(1)
(b)(3)-P.L. 86-36

b. (TS//SI//OC, NF) [redacted]

(b)(1)
(b)(3)-50 USC 403
(b)(3)-18 USC 788
(b)(3)-P.L. 86-36

(b)(3)-P.L. 86-36

(b)(1)
(b)(3)-P.L. 86-36

c. (S//SI) [redacted]

(b)(3)-P.L. 86-36

~~TOP SECRET//COMINT//ORCON, NOFORN//X1~~

[Redacted]

(b)(3)-P.L. 86-36

d. (S//SI)

[Redacted]

(b)(3)-P.L. 86-36

b. (U//FOUO)

[Redacted]

(b)(1)
(b)(3)-50 USC 403
(b)(3)-18 USC 798
(b)(3)-P.L. 86-36

(b)(1)
(b)(3)-P.L. 86-36

(1) (U)

[Redacted]

(b)(3)-P.L. 86-36

(S//SI)

[Redacted]

(b)(3)-P.L. 86-36

[Redacted]

(2) (U)

[Redacted]

(b)(3)-P.L. 86-36

a. (S//SI)

[Redacted]

(b)(3)-P.L. 86-36

[Redacted]

~~TOP SECRET//COMINT//ORCON, NOFORN//X1~~

~~TOP SECRET//COMINT//ORCON, NOFORN//X1~~

[Redacted]

(U)(3)-P.L. 86-36

(b)(1)
(b)(3)-50 USC 403
(b)(3)-P.L. 86-36

b. ~~(TS//SI)~~

[Redacted]

(3) (U)

(b)(3)-P.L. 86-36

[Redacted]

~~(TS//SI)~~

[Redacted]

(b)(3)-P.L. 86-36

4. (U) Other Activities

a. (U//FOUO)

[Redacted]

(b)(3)-P.L. 86-36

(b)(1)
(b)(3)-50 USC 403
(b)(3)-P.L. 86-36
(b)(3)-18 USC 798

~~(TS//SI//OC, NF)~~

[Redacted]

FUP

[Redacted]

~~TOP SECRET//COMINT//ORCON, NOFORN//X1~~

~~TOP SECRET//COMINT//ORCON,NOFORN//X1~~

(b)(3)-P.L. 86-36

b. (U) Assistance to Law Enforcement

~~(S//SI)~~

[Redacted]

c. (U) Working Aids

~~(U//FOUO)~~ The SID Office of Oversight and Compliance maintains

(b)(3)-P.L. 86-36

[Redacted] on its web page
for use by the NSA/CSS Enterprise. The E.O., NSA/CSS Policy Number 1-23, DoD Regulation 5240.1-R, and USSID 18 are also available on-line.

~~TOP SECRET//COMINT//ORCON,NOFORN//X1~~

NSA STAFF PROCESSING FORM

TO DIRECTOR	EXREG CONTROL NUMBER 10-1178	KCC CONTROL NUMBER IG-10490-05
THRU D/DIR, D SECRETARIAT	ACTION <input type="checkbox"/> APPROVAL <input checked="" type="checkbox"/> SIGNATURE <input type="checkbox"/> INFORMATION	EXREG SUSPENSE KCC SUSPENSE ELEMENT SUSPENSE
SUBJECT (U//FOUO) Quarterly Report to the Intelligence Oversight Board on NSA Activities—Second Quarter FY05		
DISTRIBUTION		

SUMMARY

PURPOSE: (U//FOUO) To forward to the Intelligence Oversight Board (IOB) of the President's Foreign Intelligence Advisory Board, via the Assistant to the Secretary of Defense for Intelligence Oversight (ATSD(IO)), NSA's quarterly report on its intelligence activities.

BACKGROUND: (U//FOUO) Executive Order 12333 and Executive Order 12863 require Intelligence Community agency heads and Intelligence Community General Counsels and Inspectors General, respectively, to report to the IOB on a quarterly basis concerning intelligence activities that they have reason to believe may be unlawful or contrary to Executive Order or Presidential Directive. The enclosed memorandum covers all reportable activities known to the Inspector General and General Counsel. Per PIOB letter of 6 August 1982, Agency heads are responsible for reporting separately any additional reportable activities known to them, unless the President has specifically instructed that the Board is not to be informed. The Director's signature signifies that no other activities that require reporting are known to him.

RECOMMENDATION: (U) Director sign the enclosed memorandum.

This document may be declassified and marked "UNCLASSIFIED//~~For Official Use Only~~" upon removal of enclosure(s)

Approved for Release by NSA on 06-01-2009, FOIA Case # 49107

(b)(3)-P.L. 86-36

COORDINATION/APPROVAL					
OFFICE	NAME AND DATE	SECURE PHONE	OFFICE	NAME AND DATE	SECURE PHONE
GC	Robert J. Deitz	5548s			
AGC(O)		5548s			
IG	Joel F. Brenne	3544s			
D/IG		3544s			
AIG(IO)		3544s			
			ORG D11	PHONE (Secure) 963-2984	DATE PREPARED 3 May 2005



NATIONAL SECURITY AGENCY
CENTRAL SECURITY SERVICE
FORT GEORGE G. MEADE, MARYLAND 20755-6000

2QFY05

17 May 2005

MEMORANDUM FOR THE CHAIRMAN, INTELLIGENCE OVERSIGHT BOARD

THRU: Assistant to the Secretary of Defense (Intelligence Oversight)

SUBJECT: ~~(U//FOUO)~~ Report to the Intelligence Oversight Board on NSA
Activities - INFORMATION MEMORANDUM

~~(U//FOUO)~~ Except as previously reported to you or the President, or otherwise stated in the enclosure, we have no reason to believe that any intelligence activities of the National Security Agency during the quarter ending 31 March 2005 were unlawful or contrary to Executive Order or Presidential Directive, and thus required to be reported pursuant to Section 1.7.(d) of Executive Order 12333.

~~(U//FOUO)~~ The Inspector General and the General Counsel continue to exercise oversight of Agency activities by means of inspections, surveys, training, review of directives and guidelines, and advice and counsel. These activities and other data requested by the Board or members of the staff of the Assistant to the Secretary of Defense (Intelligence Oversight) are described in the enclosure.

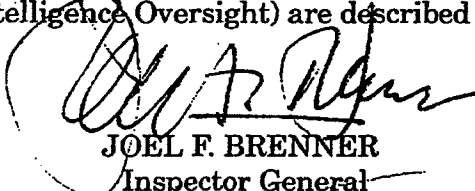
JOEL F. BRENNER
Inspector General

ROBERT L. DEITZ
General Counsel

~~(U//FOUO)~~ I concur in the report of the Inspector General and the General Counsel and hereby make it our combined report.

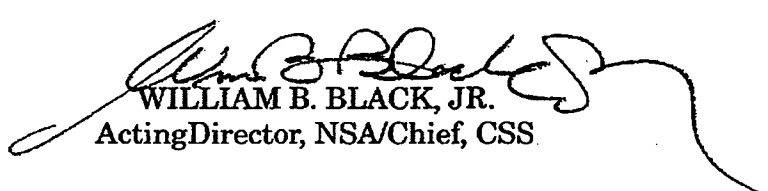
WILLIAM B. BLACK, JR.
Acting Director, NSA/Chief, CSS

Encl:

Quarterly Report with NSA/CSS Policy 1-23

This Memorandum is Unclassified
Upon Removal of Enclosure

DERIVED FROM: NSA/CSSPM 1-52
DATED: 23NOV04
DECLASSIFY ON: 20291123

1. (U) INSPECTOR GENERAL ACTIVITIES

a. ~~(C//SI)~~ During this quarter, the Office of Inspector General (OIG) reviewed various intelligence activities of the National Security Agency/Central Security Service (NSA/CSS) to determine whether they were conducted in accordance with applicable statutes, Executive Orders (EOs), Attorney General (AG) procedures, and Department of Defense (DoD) and internal directives. With few exceptions, the issues presented were routine and indicated that the operating elements understand the restrictions on NSA/CSS activities.

b. ~~(U//FOUO)~~ Along with inspectors from [REDACTED] the NSA
[REDACTED] the NSA
OIG completed a joint inspection of the Kunia Regional Security Operations Center (KRSOC), Kunia, Hawaii. The inspection team found that the KRSOC IO program manager lacked the authority to manage the IO program centrally, the IO training materials contained inaccuracies, and the training accounting process was fragmented. The deficiencies will be monitored by the NSA OIG through correction.

(b)(3)-P.L. 86-36

c. As reported in the fourth quarter fiscal year 2004 (See report dated 24 November 2004), the NSA OIG [REDACTED]

(b)(3)-P.L. 86-36

[REDACTED]
[REDACTED] The two intelligence-related actions resulting from the inspection, a continuity guide and quarterly reporting process have been completed.

(b)(3)-P.L. 86-36

2. (U) GENERAL COUNSEL ACTIVITIES

~~(C//SI)~~ The NSA Office of General Counsel (OGC) reviewed various intelligence activities of the NSA/CSS to determine whether they were conducted in accordance with applicable statutes, EOs, AG procedures, and DoD and internal directives. The OGC advised Agency elements on a number of questions, including the collection and dissemination of communications of or concerning U.S. persons (USP); the reporting of possible violations of federal criminal law contained in SIGINT product; the testing of electronic equipment; and the applicability of the Foreign Intelligence Surveillance Act. (FISA). With few exceptions, the issues presented were routine and indicated that the operating elements understand the restrictions on NSA/CSS activities. The OGC did not file any reports with the Intelligence Oversight Board during this quarter.

Derived From: NSA/CSSM 1-52

Dated: 20041123

Declassify On: 20291123

3. (U) SIGINT ACTIVITIES

a. (S//SI) [Redacted]

(b)(1)
(b)(3)-50 USC 403
(b)(3)-18 USC 798
(b)(3)-P.L. 86-36

(b)(3)-P.L. 86-36

(1) (U) [Redacted]

a. (S//SI) [Redacted]

[Redacted]

b. (S//SI) [Redacted]

[Redacted]

(b)(1)
(b)(3)-P.L. 86-36

(b)(3)-P.L. 86-36

(2) (U) [Redacted]

a. (S//SI//NF) [Redacted]

[Redacted]

[1] (TS//SI) [Redacted]

[Redacted]

(b)(1)
(b)(3)-50 USC 403
(b)(3)-18 USC 798
(b)(3)-P.L. 86-36

[2] (TS//SI) [Redacted]

[Redacted]

(b)(1)
(b)(3)-50 USC 403
(b)(3)-18 USC 798
(b)(3)-P.L. 86-36

2ND QTR FY05

[3] (S//SI)

(b)(3)-P.L. 86-36

[4] (TS//SI//NF)

(b)(3)-P.L. 86-36

b. (U//FOUO)

(b)(3)-P.L. 86-36

(b)(1)
(b)(3)-50 USC 403
(b)(3)-18 USC 798
(b)(3)-P.L. 86-36

(1) (U)

(S//SI)

(b)(1)
(b)(3)-P.L. 86-36

(2) (U)

(b)(3)-P.L. 86-36

a. (S//SI)

(b)(1)
(b)(3)-50 USC 403
(b)(3)-P.L. 86-36

~~TOP SECRET//COMINT//NOFORN//20291123~~

b. (TS//SI)

[Redacted]

(b)(3)-P.L. 86-36

(3) (U)

[Redacted]

(S//SI)

[Redacted]

4. (U) Other Activities

(b)(3)-P.L. 86-36

a. (U//FOUO)

[Redacted]

(b)(3)-P.L. 86-36

(1) (TS//SI//OC, NE)

[Redacted]

[Redacted]

(b)(3)-P.L. 86-36

(2) (TS//SI//NF)

[Redacted]

(b)(1)
(b)(3)-50 USC 403
(b)(3)-18 USC 798
(b)(3)-P.L. 86-36

~~TOP SECRET//COMINT//NOFORN//20291123~~

[Redacted]

(b)(3)-50 USC 403
(b)(3)-18 USC 798
(b)(3)-P.L. 86-36

b. (U//FOUO) [Redacted]

(TS//SI) [Redacted]

(b)(3)-P.L. 86-36

[Redacted]

(b)(3)-50 USC 403
(b)(3)-P.L. 86-36

c. (U//FOUO) [Redacted]

(b)(2)
(b)(3)-P.L. 86-36

(S//SI//NF) [Redacted]

[Redacted]

d. (U) Assistance to Law Enforcement

(S//SI) [Redacted]

[Redacted]

(b)(3)-P.L. 86-36

e. (U) Working Aids

(b)(3)-P.L. 86-36

(U//FOUO) The SID Office of Oversight and Compliance maintains [Redacted]

[Redacted] on its web page for use by the NSA/CSS Enterprise. The E.O., NSA/CSS Policy Number 1-23, DoD Regulation 5240.1-R, and USSID 18 are also available on-line.



NATIONAL SECURITY AGENCY
CENTRAL SECURITY SERVICE
FORT GEORGE G. MEADE, MARYLAND 20755-6000

17 May 2005

MEMORANDUM FOR THE CHAIRMAN, INTELLIGENCE OVERSIGHT BOARD

THRU: Assistant to the Secretary of Defense (Intelligence Oversight)

SUBJECT: (U//FOUO) Report to the Intelligence Oversight Board on NSA
Activities - INFORMATION MEMORANDUM

(U//FOUO) Except as previously reported to you or the President, or otherwise stated in the enclosure, we have no reason to believe that any intelligence activities of the National Security Agency during the quarter ending 31 March 2005 were unlawful or contrary to Executive Order or Presidential Directive, and thus required to be reported pursuant to Section 1.7.(d) of Executive Order 12333.

(U//FOUO) The Inspector General and the General Counsel continue to exercise oversight of Agency activities by means of inspections, surveys, training, review of directives and guidelines, and advice and counsel. These activities and other data requested by the Board or members of the staff of the Assistant to the Secretary of Defense (Intelligence Oversight) are described in the enclosure.

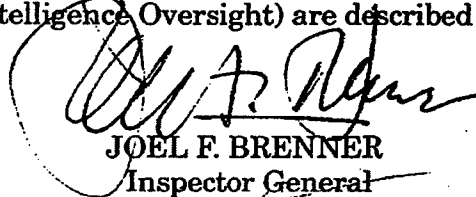
JOEL F. BRENNER
Inspector General

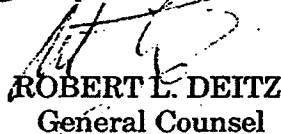
ROBERT L. DEITZ
General Counsel

(U//FOUO) I concur in the report of the Inspector General and the General Counsel and hereby make it our combined report.

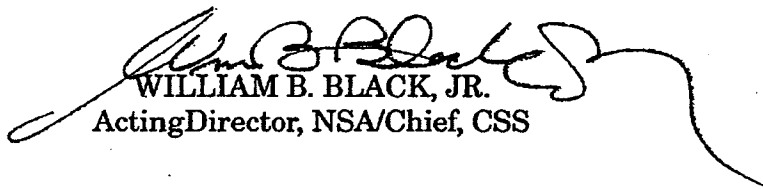
WILLIAM B. BLACK, JR.
Acting Director, NSA/Chief, CSS

Encl:
Quarterly Report with NSA/CSS Policy 1-23

This Memorandum is Unclassified
Upon Removal of Enclosure

DERIVED FROM: NSA/CSSPM 1-52
DATED: 23NOV04
DECLASSIFY ON: 20291123

1. (U) INSPECTOR GENERAL ACTIVITIES

a. ~~(C//SI)~~ During this quarter, the Office of Inspector General (OIG) reviewed various intelligence activities of the National Security Agency/Central Security Service (NSA/CSS) to determine whether they were conducted in accordance with applicable statutes, Executive Orders (EOs), Attorney General (AG) procedures, and Department of Defense (DoD) and internal directives. With few exceptions, the issues presented were routine and indicated that the operating elements understand the restrictions on NSA/CSS activities.

b. ~~(U//FOUO)~~ Along with inspectors from [redacted] the NSA
[redacted] the NSA
OIG completed a joint inspection of the Kunia Regional Security Operations Center (KRSOC), Kunia, Hawaii. The inspection team found that the KRSOC IO program manager lacked the authority to manage the IO program centrally, the IO training materials contained inaccuracies, and the training accounting process was fragmented. The deficiencies will be monitored by the NSA OIG through correction.

(b)(3)-P.L. 86-36

c. As reported in the fourth quarter fiscal year 2004 (See report dated 24 November 2004), the NSA OIG [redacted]
[redacted]
[redacted] The two intelligence-related actions resulting from the inspection, a continuity guide and quarterly reporting process have been completed.

(b)(3)-P.L. 86-36

2. (U) GENERAL COUNSEL ACTIVITIES

~~(C//SI)~~ The NSA Office of General Counsel (OGC) reviewed various intelligence activities of the NSA/CSS to determine whether they were conducted in accordance with applicable statutes, EOs, AG procedures, and DoD and internal directives. The OGC advised Agency elements on a number of questions, including the collection and dissemination of communications of or concerning U.S. persons (USP); the reporting of possible violations of federal criminal law contained in SIGINT product; the testing of electronic equipment; and the applicability of the Foreign Intelligence Surveillance Act. (FISA). With few exceptions, the issues presented were routine and indicated that the operating elements understand the restrictions on NSA/CSS activities. The OGC did not file any reports with the Intelligence Oversight Board during this quarter.

Derived From: NSA/CSSM 1-52

Dated: 20041123

Declassify On: 20291123

3. (U) SIGINT ACTIVITIES

a. (S//SI) [Redacted]

(b)(3)-P.L. 86-36

(b)(1)
(b)(3)-50 USC 403
(b)(3)-18 USC 798
(b)(3)-P.L. 86-36

(1) (U) [Redacted]

(b)(1)
(b)(3)-P.L. 86-36

a. (S//SI) [Redacted]

b. (S//SI) [Redacted]

(b)(3)-P.L. 86-36

(2) (U) [Redacted]

(b)(3)-P.L. 86-36

(b)(1)
(b)(3)-P.L. 86-36

a. (S//SI//NF) [Redacted]

[1] (TS//SI) [Redacted]

[2] (TS//SI) [Redacted]

(b)(3)-50 USC 403
(b)(3)-18 USC 798
(b)(3)-P.L. 86-36

[3] ~~(S//SI) NSA~~ [Redacted]
 [Redacted]
 [Redacted]

(b)(3)-P.L. 86-36

[4] ~~(TS//SI//NF)~~ [Redacted]
 [Redacted]
 [Redacted]

(b)(3)-P.L. 86-36

b. (U//FOUO) [Redacted]

(b)(1)
(b)(3)-50 USC 403
(b)(3)-18 USC 798
(b)(3)-P.L. 86-36

(b)(3)-P.L. 86-36

(1) (U) [Redacted]

~~(S//SI)~~ [Redacted]
 [Redacted]

(b)(1)
(b)(3)-P.L. 86-36

[Redacted]

[Redacted]

(b)(3)-P.L. 86-36

(2) (U) [Redacted]

a. ~~(S//SI)~~ [Redacted]
 [Redacted]

(b)(3)-P.L. 86-36

(b)(1)
(b)(3)-50 USC 403
(b)(3)-P.L. 86-36

~~TOP SECRET//COMINT//NOFORN//20291123~~

b. ~~(TS//SI)~~

(b)(3)-P.L. 86-36

[Redacted]

(3) (U)

[Redacted]

~~(S//SI)~~

(b)(3)-P.L. 86-36

[Redacted]

4. (U) Other Activities

(b)(3)-P.L. 86-36

a. (U//FOUO)

[Redacted]

(1) ~~(TS//SI//OC, NF)~~

[Redacted]

(b)(3)-P.L. 86-36

(2) ~~(TS//SI//NF)~~

[Redacted]

(b)(1)
(b)(3)-50 USC 403
(b)(3)-18 USC 798
(b)(3)-P.L. 86-36

~~TOP SECRET//COMINT//NOFORN//20291123~~

[Redacted]

(b)(1)
(b)(3)-50 USC 403
(b)(3)-18 USC 798
(b)(3)-P.L. 86-36

(b)(1)
(b)(3)-50 USC 403
(b)(3)-P.L. 86-36

b. (U//FOUO) [Redacted]

(b)(3)-P.L. 86-36

~~(S//SI)~~ [Redacted]

[Redacted]

(b)(3)-P.L. 86-36

[Redacted]

c. (U//FOUO) [Redacted]

(b)(2)
(b)(3)-P.L. 86-36

(b)(3)-P.L. 86-36

~~(S//SI//NF)~~ [Redacted]

[Redacted]

d. (U) Assistance to Law Enforcement

~~(S//SI)~~ [Redacted]

(b)(3)-P.L. 86-36

[Redacted]

e. (U) Working Aids

(U//FOUO) The SID Office of Oversight and Compliance maintains [Redacted]

(b)(3)-P.L. 86-36

[Redacted] on its web page for use by the NSA/CSS Enterprise. The E.O., NSA/CSS Policy Number 1-23, DoD Regulation 5240.1-R, and USSID 18 are also available on-line.

SECURITY CLASSIFICATION

NSA STAFF PROCESSING FORM

TO DIRECTOR	EXREG CONTROL NUMBER 24223	KCC CONTROL NUMBER IG-10525-05
THRU D/DIR <i>[Signature]</i> , D SECRETARIAT	ACTION <input type="checkbox"/> APPROVAL <input checked="" type="checkbox"/> SIGNATURE <input type="checkbox"/> INFORMATION	EXREG SUSPENSE KCC SUSPENSE ELEMENT SUSPENSE
SUBJECT (U//FOUO) Quarterly Report to the Intelligence Oversight Board on NSA Activities—Third Quarter FY05		

DISTRIBUTION

SUMMARY

PURPOSE: (U//FOUO) To forward to the Intelligence Oversight Board (IOB) of the President's Foreign Intelligence Advisory Board, via the Assistant to the Secretary of Defense for Intelligence Oversight (ATSD(IO)), NSA's quarterly report on its intelligence activities.

BACKGROUND: (U//FOUO) Executive Order 12333 and Executive Order 12863 require Intelligence Community agency heads and Intelligence Community General Counsels and Inspectors General, respectively, to report to the IOB on a quarterly basis concerning intelligence activities that they have reason to believe may be unlawful or contrary to Executive Order or Presidential Directive. The enclosed memorandum covers all reportable activities known to the Inspector General and General Counsel. Per PIOB letter of 6 August 1982, Agency heads are responsible for reporting separately any additional reportable activities known to them, unless the President has specifically instructed that the Board is not to be informed. The Director's signature signifies that no other activities that require reporting are known to him.

RECOMMENDATION: (U) Director sign the enclosed memorandum.

This document may be declassified and marked "UNCLASSIFIED//~~For Official Use Only~~" upon removal of enclosure(s)

Approved for Release by NSA on 06-01-2009, FOIA Case # 49107

COORDINATION/APPROVAL

OFFICE	NAME AND DATE	SECURE PHONE	OFFICE	NAME AND DATE	SECURE PHONE
GC	Robert L. Deitz <i>[Signature]</i>	5548s	Das	<i>[Redacted]</i> 8/17	963-3201
AGC(O)	<i>[Redacted]</i>	3121s			
IG	Joel F. Brenner <i>[Signature]</i>	3544s		(b) (3) - P. L. 86-36	
D/IG	<i>[Signature]</i> 8/19/05	3544s			
AIG(IO)	<i>[Signature]</i> 8/19/05	3544s			
<i>[Redacted]</i>			ORG D11	PHONE (Secure) 963-2984	DATE PREPARED 4 August 2005



NATIONAL SECURITY AGENCY
CENTRAL SECURITY SERVICE
FORT GEORGE G. MEADE, MARYLAND 20755-6000

22 August 2005

30FV05

MEMORANDUM FOR THE CHAIRMAN, INTELLIGENCE OVERSIGHT BOARD

THRU: Assistant to the Secretary of Defense (Intelligence Oversight)

SUBJECT: (U//~~FOUO~~) Report to the Intelligence Oversight Board on NSA
Activities - INFORMATION MEMORANDUM

(U//~~FOUO~~) Except as previously reported to you or the President, or otherwise stated in the enclosure, we have no reason to believe that any intelligence activities of the National Security Agency during the quarter ending 30 June 2005 were unlawful or contrary to Executive Order or Presidential Directive, and thus required to be reported pursuant to Section 1.7.(d) of Executive Order 12333.

(U//~~FOUO~~) The Inspector General and the General Counsel continue to exercise oversight of Agency activities by means of inspections, surveys, training, review of directives and guidelines, and advice and counsel. These activities and other data requested by the Board or members of the staff of the Assistant to the Secretary of Defense (Intelligence Oversight) are described in the enclosure.

JOEL F. BRENNER
Inspector General

ROBERT L. DEITZ
General Counsel

(U//~~FOUO~~) I concur in the report of the Inspector General and the General Counsel and hereby make it our combined report.

KEITH B. ALEXANDER
Lieutenant General, U. S. Army
Director, NSA/Chief, CSS

Encl:

Quarterly Report with NSA/CSS Policy 1-23

This Memorandum is Unclassified
Upon Removal of Enclosure

DERIVED FROM: NSA/CSSPM 1-52
DATED: 23NOV04
DECLASSIFY ON: 20291123

1. (U) INSPECTOR GENERAL ACTIVITIES

a. (~~C//SI~~) During this quarter, the Office of Inspector General (OIG) reviewed various intelligence activities of the National Security Agency/Central Security Service (NSA/CSS) to determine whether they were conducted in accordance with applicable statutes, Executive Orders (EOs), Attorney General (AG) procedures, and Department of Defense (DoD) and internal directives. With few exceptions, the issues presented were routine and indicated that the operating elements understand the restrictions on NSA/CSS activities.

b. (~~U//FOUO~~) Along with inspectors from the [redacted] the NSA
OIG completed a joint inspection of [redacted]
[redacted] The inspection team found that some personnel who did not have access to the Sensitive Compartmented Information Facility (SCIF) had not received initial intelligence oversight training. NSA OIG will monitor this deficiency through correction.

c. (~~U//FOUO~~) The OIG conducted an inspection of the NSA/CSS Representative Pacific (NCRPAC). Three Intelligence Oversight (IO) training weaknesses were documented and quickly rectified. USSID SP0018 (formerly USSID 18) training was added to the training program, recording keeping was automated and the web-based training was standardized for all NCPAC divisions.

d. (~~U//FOUO~~) A special study of the NSA/CSS [redacted] revealed deficient training accountability. Only 61% of the [redacted] workforce had received the required IO training in 2004, and as of the study publication, training compliance has risen to 84% for 2005. The [redacted] lacks a formal tracking and follow-up system to ensure 100% training compliance. NSA OIG will monitor this deficiency through correction.

e. (~~U//FOUO~~) A follow-up inspection of the [redacted] and NSA/CSS Representative [redacted] found that the training and documentation weaknesses cited in our 13 September 2004 report have been strengthened. Training and documentation procedures have been standardized and managed by an appointed IO Program Manager.

Derived From: NSA/CSSM 1-52

Dated: 20041123

Declassify On: 20300706

2. (U) GENERAL COUNSEL ACTIVITIES

(C//SI) The NSA Office of General Counsel (OGC) reviewed various intelligence activities of the NSA/CSS to determine whether they were conducted in accordance with applicable statutes, EOs, AG procedures, and DoD and internal directives. The OGC advised Agency elements on a number of questions, including the collection and dissemination of communications of or concerning U.S. persons (USP); the reporting of possible violations of federal criminal law contained in SIGINT product; the testing of electronic equipment; and the applicability of the Foreign Intelligence Surveillance Act (FISA). With few exceptions, the issues presented were routine and indicated that the operating elements understand the restrictions on NSA/CSS activities. The OGC did not file any reports with the Intelligence Oversight Board during this quarter.

3. (U) SIGINT ACTIVITIES

a. (S//SI) [redacted]

(1) (U) [redacted]

a. (TS//SI) [redacted]

[Large redacted block of text]

b. (S//SI) [redacted]

(2) (U) [redacted]

a. (S//SI//NF) [redacted]

[Redacted block of text]

(b)(1)
(b)(3)-50 USC 403
(b)(3)-18 USC 798
(b)(3)-P.L. 86-36

(b)(3)-P.L. 86-36

P.L. 86-36

(b)(3)-P.L. 86-36

(b)(1)
(b)(3)-P.L. 86-36

(b)(3)-P.L. 86-36

(b)(3)-P.L. 86-36

~~TOP SECRET//COMINT//NOFORN//20300706~~

[Redacted]

(C)

[1] (U//FOUO)

(b)(1)
(b)(3)-P.L. 86-36

[Redacted]

a. (TS//SI)

[Redacted]

(b)(3)-P.L. 86-36

(b)(1)
(b)(3)-60 USC 403
(b)(3)-18 USC 795
(b)(3)-P.L. 86-36

b. (S//SI)

[Redacted]

(b)(1)
(b)(3)-P.L. 86-36

c. (TS//SI)

[Redacted]

(b)(3)-P.L. 86-36

(b)(3)-P.L. 86-36

(b)(1)
(b)(3)-60 USC 403
(b)(3)-18 USC 795
(b)(3)-P.L. 86-36

[2] (TS//SI)

[Redacted]

(b)(3)-P.L. 86-36

[3] (TS//SI)

[Redacted]

(b)(3)-P.L. 86-36

~~TOP SECRET//COMINT//NOFORN//20300706~~

[Redacted]

[4] ~~(TS//SI)~~

[Redacted]

(b)(3)-P.L. 86-36

[Redacted]

(b)(1)
(b)(3)-50 USC 403
(b)(3)-18 USC 798
(b)(3)-P.L. 86-36

~~(S//SI)~~

[5] ~~(U//FOUO)~~

[Redacted]

[Redacted]

(b)(3)-P.L. 86-36

[6] ~~(S//SI)~~

[Redacted]

[Redacted]

(b)(3)-P.L. 86-36

(b)(1)
(b)(3)-50 USC 403
(b)(3)-P.L. 86-36
(b)(3)-18 USC 798

(b)(3)-P.L. 86-36

[7] ~~(S//SI)~~

[Redacted]

[Redacted]

(b)(1)
(b)(3)-P.L. 86-36

b. ~~(U//FOUO)~~

[Redacted]

(b)(3)-P.L. 86-36

(1) (U)

[Redacted]

~~(S//SI)~~

[Redacted]

(b)(3)-P.L. 86-36

(b)(1)
(b)(3)-P.L. 86-36

[Redacted]

(b)(3)-P.L. 86-36

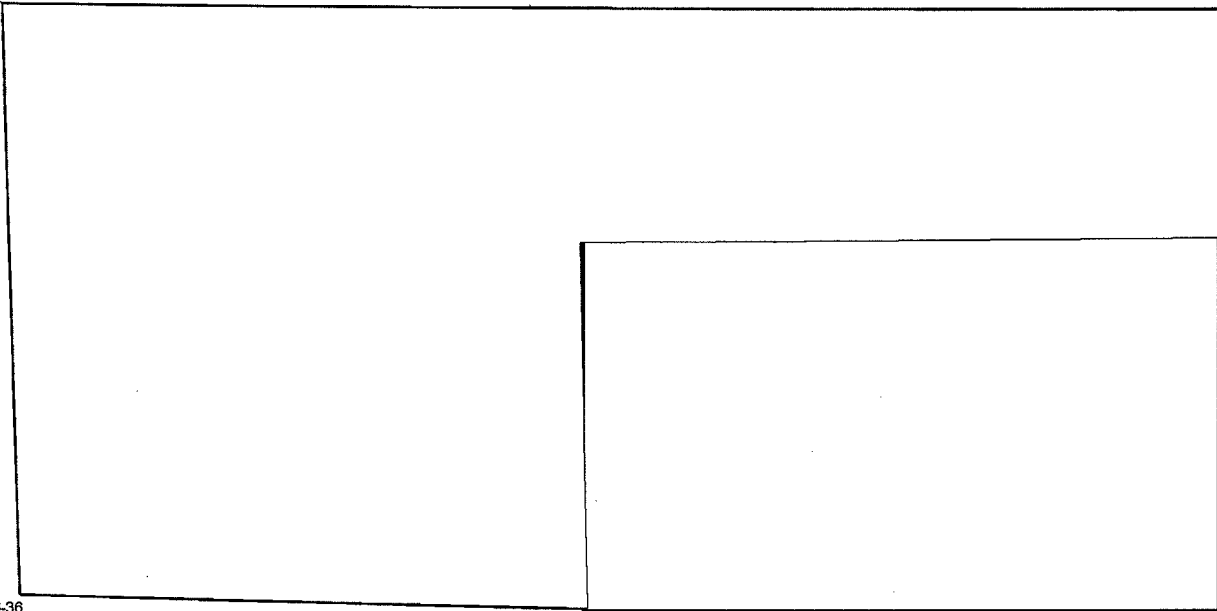

(b)(3)-P.L. 86-36

(2) (U)



(b)(1)
(b)(3)-P.L. 86-36

a. (S//SI)

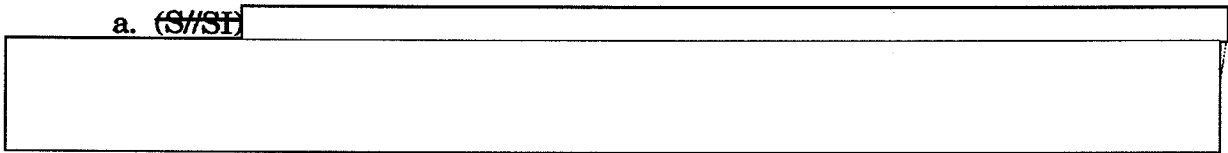

(b)(1)
(b)(3)-50 USC 403
(b)(3)-P.L. 86-36

b. (TS//SI)

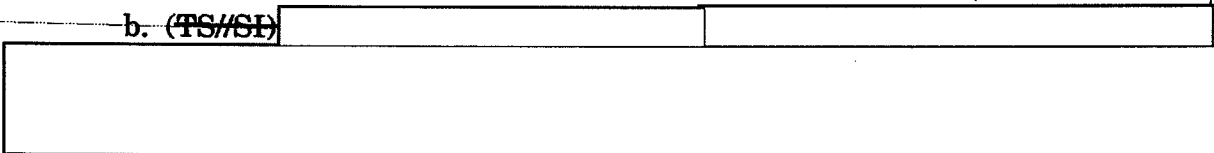

(b)(3)-P.L. 86-36

c. (S//SI//NF)

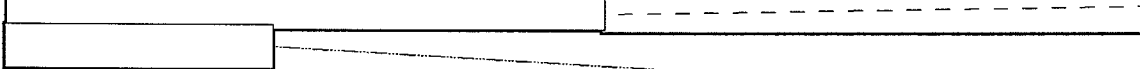
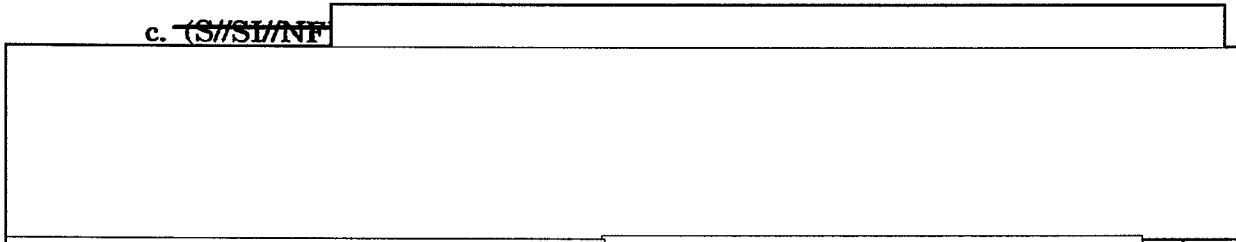

(b)(1)
(b)(3)-50 USC 403
(b)(3)-P.L. 86-36
(b)(3)-18 USC 798

(3) (U)

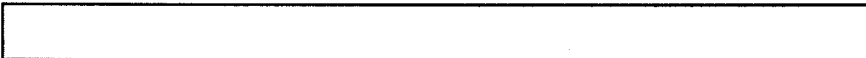

(b)(3)-P.L. 86-36

a. (S//SI)

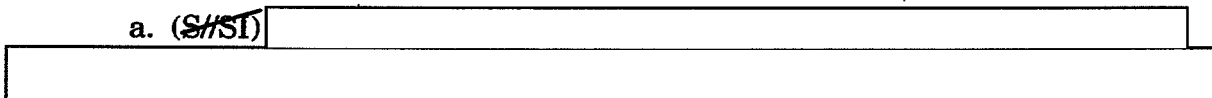

(b)(3)-P.L. 86-36

(b)(3)-P.L. 86-36

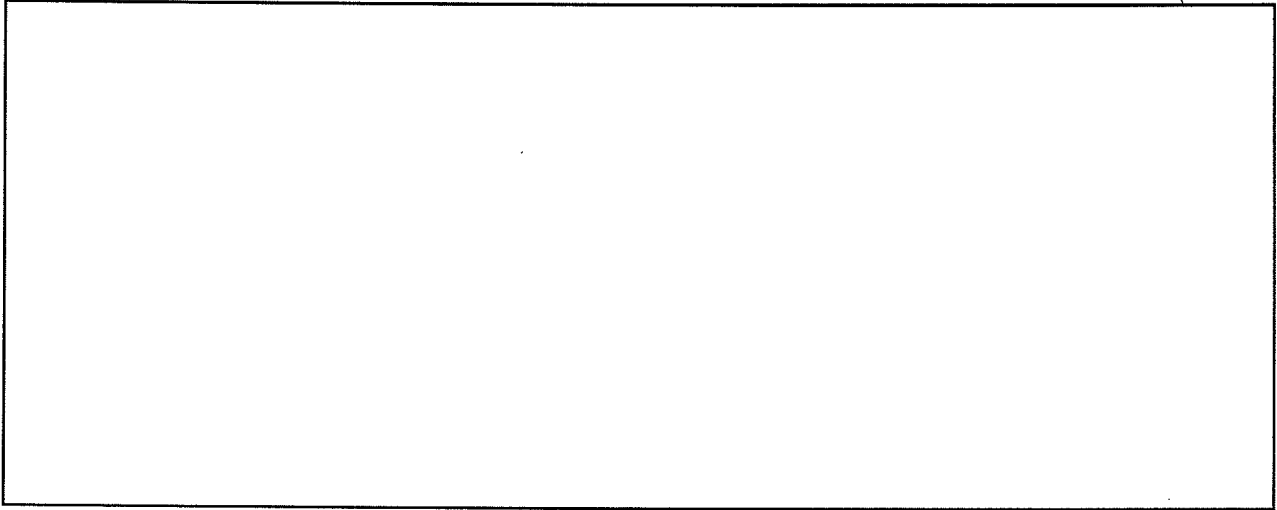

b. (TS//SI)

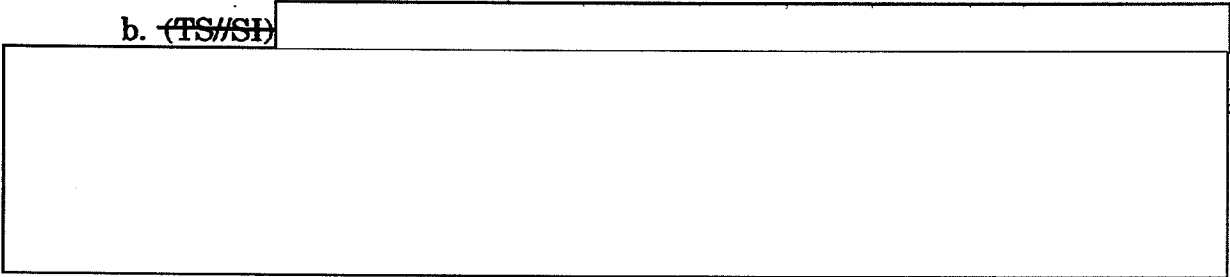

(1)
(3)-P.L. 86-36

c. (TS//SI)

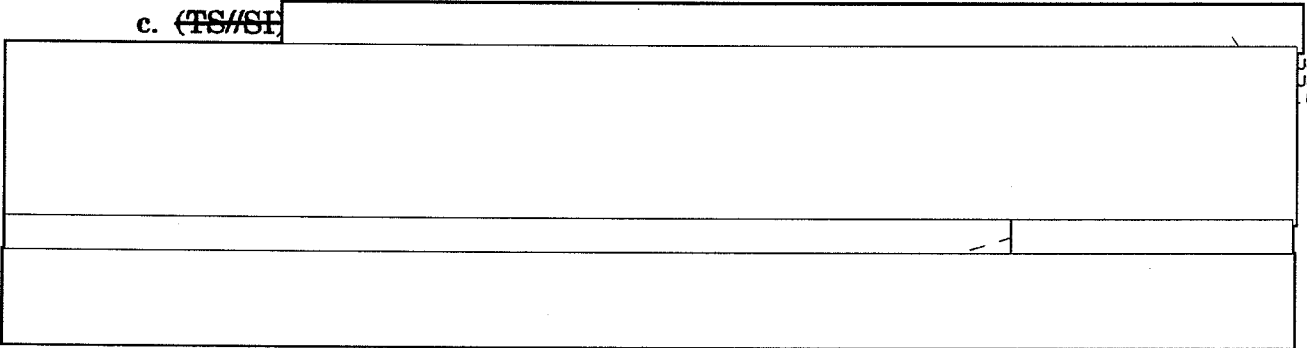

JSC 403
JSC 798
86-36

4. (U) Other Activities

a. (U//FOUO)

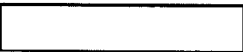

(b)(3)-P.L. 86-36

(b)(1)
(b)(3)-50 USC 403
(b)(3)-P.L. 86-36
(b)(3)-48 USC 798

(1) (TS//SI//NF)

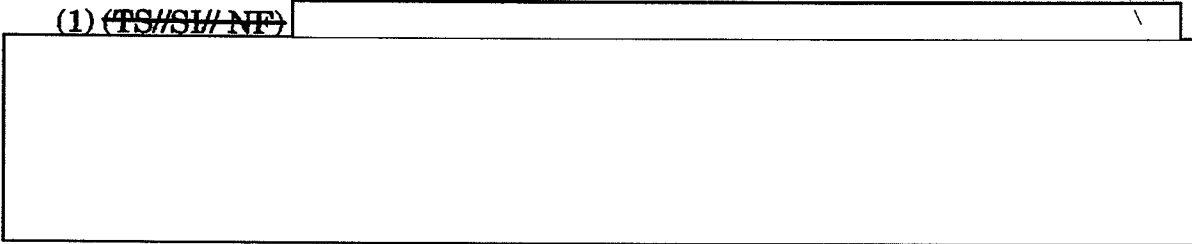

(b)(3)-P.L. 86-36

[Redacted]

(b)(1)
(b)(3)-50 USC 403
(b)(3)-P.L. 86-36

(2) (T//SI//NF)

[Redacted]

(1)
(3)-50 USC 403
(3)-P.L. 86-36
(3)-18 USC 798

(b)(3)-P.L. 86-36

(b)(3)-P.L. 86-36
(b)(1)
(b)(3)-50 USC 403

c. (U//FOUO)

[Redacted]

(TS//SI)

[Redacted]

(b)(1)
(b)(3)-P.L. 86-36

d. (U) Assistance to Law Enforcement

(b)(3)-P.L. 86-36

(S//SI)

[Redacted]

e. (U) Working Aids

(U//FOUO) The SID Office of Oversight and Compliance maintains [Redacted] on its web page for use by the NSA/CSS Enterprise. The E.O., NSA/CSS Policy Number 1-23, DoD Regulation 5240.1-R, and USSID SP0018 are also available on-line.

SECURITY CLASSIFICATION

NSA STAFF PROCESSING FORM

TO DIRECTOR	EXREG CONTROL NUMBER 46179	KCC CONTROL NUMBER IG-10573-05
THRU D/DIR <i>[Signature]</i> , D SECRETARIAT	ACTION <input type="checkbox"/> APPROVAL <input checked="" type="checkbox"/> SIGNATURE <input type="checkbox"/> INFORMATION	EXREG SUSPENSE KCC SUSPENSE ELEMENT SUSPENSE
SUBJECT (U//FOUO) Quarterly Report to the Intelligence Oversight Board on NSA Activities—Fourth Quarter FY05		
DISTRIBUTION		

SUMMARY

PURPOSE: (U//FOUO) To forward to the Intelligence Oversight Board (IOB) of the President's Foreign Intelligence Advisory Board, via the Assistant to the Secretary of Defense for Intelligence Oversight (ATSD(IO)), NSA's quarterly report on its intelligence activities.

BACKGROUND: (U//FOUO) Executive Order 12333 and Executive Order 12863 require Intelligence Community agency heads and Intelligence Community General Counsels and Inspectors General, respectively, to report to the IOB on a quarterly basis concerning intelligence activities that they have reason to believe may be unlawful or contrary to Executive Order or Presidential Directive. The enclosed memorandum covers all reportable activities known to the Inspector General and General Counsel. Per PIOB letter of 6 August 1982, Agency heads are responsible for reporting separately any additional reportable activities known to them, unless the President has specifically instructed that the Board is not to be informed. The Director's signature signifies that no other activities that require reporting are known to him.

RECOMMENDATION: (U) Director sign the enclosed memorandum.

This document may be declassified and marked "UNCLASSIFIED//For Official Use Only" upon removal of enclosure(s)

Approved for Release by NSA on 06-01-2009, FOIA Case # 49107

(b) (3) - P.L. 86-36

COORDINATION/APPROVAL					
OFFICE	NAME AND DATE	SECURE PHONE	OFFICE	NAME AND DATE	SECURE PHONE
GC	Robert L. Deitz <i>[Signature]</i> 10/7/2005	5548s	DoS		963-3201
AGC(O)	<i>[Signature]</i>	3121s			
IG	Joel F. Brenner <i>[Signature]</i>	3544s			
D/IG	<i>[Signature]</i>	3544s			
AIG(IO)		3544s			
ORIGINATOR			ORG. D11	PHONE (Secure) 963-2984	DATE PREPARED 22 November 2005

~~TOP SECRET//COMINT//NOFORN//2 J1123~~

NATIONAL SECURITY AGENCY
 CENTRAL SECURITY SERVICE
 FORT GEORGE G. MEADE, MARYLAND 20755-6000

14 December 2005

MEMORANDUM FOR THE CHAIRMAN, INTELLIGENCE OVERSIGHT BOARD

THRU: Assistant to the Secretary of Defense (Intelligence Oversight)

SUBJECT: (~~U//FOUO~~) Report to the Intelligence Oversight Board on NSA
 Activities - INFORMATION MEMORANDUM

(~~U//FOUO~~) Except as previously reported to you or the President, or otherwise stated in the enclosure, we have no reason to believe that any intelligence activities of the National Security Agency during the quarter ending 30 September 2005 were unlawful or contrary to Executive Order or Presidential Directive, and thus required to be reported pursuant to Section 1.7.(d) of Executive Order 12333.

(~~U//FOUO~~) The Inspector General and the General Counsel continue to exercise oversight of Agency activities by means of inspections, surveys, training, review of directives and guidelines, and advice and counsel. These activities and other data requested by the Board or members of the staff of the Assistant to the Secretary of Defense (Intelligence Oversight) are described in the enclosure.

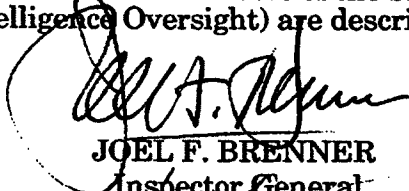
 JOEL F. BRENNER
 Inspector General

 ROBERT L. DEITZ
 General Counsel

(~~U//FOUO~~) I concur in the report of the Inspector General and the General Counsel and hereby make it our combined report.

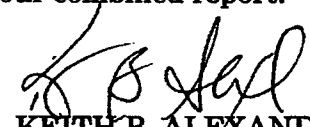
 KEITH B. ALEXANDER
 Lieutenant General, U. S. Army
 Director, NSA/Chief, CSS

Encl:

Quarterly Report with NSA/CSS Policy 1-23

This Memorandum is Unclassified
 Upon Removal of Enclosure

DERIVED FROM: NSA/CSSPM 1-52
 DATED: 23NOV04
 DECLASSIFY ON: 20291123

~~TOP SECRET//COMINT//NOFORN//20291123~~

1. (U) INSPECTOR GENERAL ACTIVITIES

a. ~~(C//SI)~~ During this quarter, the Office of Inspector General (OIG) reviewed various intelligence activities of the National Security Agency/Central Security Service (NSA/CSS) to determine whether they were conducted in accordance with applicable statutes, Executive Orders (EOs), Attorney General (AG) procedures, and Department of Defense (DoD) and internal directives. With few exceptions, the issues presented were routine and indicated that the operating elements understand the restrictions on NSA/CSS activities.

(b)(3)-P.L. 86-36

b. ~~(U//FOUO)~~ The inspection of the [redacted] conducted in August 2004 was closed with both intelligence oversight (IO) findings rectified. Reporting feedback was provided and IO program processes were documented to ensure program sustainability.

2. (U) GENERAL COUNSEL ACTIVITIES

~~(C//SI)~~ The NSA/CSS Office of General Counsel (OGC) reviewed various intelligence activities of the NSA/CSS to determine whether they were conducted in accordance with applicable statutes, EOs, AG procedures, and DoD and internal directives. The OGC advised Agency elements on a number of questions, including the collection and dissemination of communications of or concerning U.S. persons (USP); the reporting of possible violations of federal criminal law contained in signals intelligence (SIGINT) product; the testing of electronic equipment, and the applicability of the Foreign Intelligence Surveillance Act (FISA). With few exceptions, the issues presented were routine and indicated that the operating elements understand the restrictions on NSA/CSS activities. The OGC directed the briefing of employees

[redacted]
[redacted] The OGC did not file any reports with the Intelligence Oversight Board during this quarter.

(b)(1)
(b)(3)-50 USC 403
(b)(3)-P.L. 86-36

(b)(3)-P.L. 86-36

3. (U) SIGINT ACTIVITIES

a. ~~(S//SI)~~ [redacted]

(1) (U) [redacted]

(b)(1)
(b)(3)-P.L. 86-36

a. ~~(TS//SI)~~ [redacted]

Derived From: NSA/CSSM 1-52
Dated: 20041123
Declassify On: 20291123

[Redacted]

[Redacted]

[Redacted]

[Redacted]

(b)(3)-P.L. 86-36

(b)(1)
(b)(3)-P.L. 86-36

b. (S//SI)

[Redacted]

(2) (U)

[Redacted]

(b)(1)
(b)(3)-P.L. 86-36

(b)(1)
(b)(3)-50 USC 403
(b)(3)-18 USC 798
(b)(3)-P.L. 86-36

a. (S//SI//NF)

[Redacted]

[Redacted]

[Redacted]

[Redacted]

[Redacted]

[Redacted]

[Redacted]

[Redacted]

(b)(3)-P.L. 86-36

(b)(3)-P.L. 86-36

b. (U//FOUO)

[Redacted]

[Redacted]

[Redacted]

[Redacted]

[Redacted]

[Redacted]

[Redacted]

[Redacted]

[Redacted]

(b)(1)
(b)(3)-P.L. 86-36

b. (TS//SI)

[Redacted]

[Redacted]

[Redacted]

[Redacted]

[Redacted]

(b)(3)-P.L. 86-36

(b)(3)-P.L. 86-36

[Redacted]

b. (U//FOUO) [Redacted]

(1) (U) [Redacted]

(b)(3)-P.L. 86-36

(S//SI)

[Redacted]

(b)(1)
(b)(3)-P.L. 86-36

[Redacted]

(b)(3)-P.L. 86-36

(2) (U) [Redacted]

a. (S//SI) [Redacted]

[Redacted]

b. (TS//SI) [Redacted]

[Redacted]

(b)(1)
(b)(3)-50 USC 403
(b)(3)-P.L. 86-36

(b)(3)-P.L. 86-36

(3) (U)

[Redacted]

(b)(3)-P.L. 86-36

a. (S//SI)

[Redacted]

(b)(3)-P.L. 86-36

4. (U) Other Activities

a. (U//FOUO)

[Redacted]

(b)(3)-P.L. 86-36

(b)(1)
(b)(3)-50 USC 403
(b)(3)-P.L. 86-36
(b)(3)-18 USC 798

(1) (TS//SI//NF)

[Redacted]

the

(2) (TS//SI//NF)

[Redacted]

~~TOP SECRET//COMINT//NOFORN//MR~~

[Redacted]

(b)(1)
(b)(3)-50 USC 403
(b)(3)-P.L. 88-36
(b)(3)-18 USC 798

(a) ~~(TS//SI//NF)~~

[Redacted]

(b) ~~(TS//SI//NF)~~

[Redacted]

(c) ~~(TS//SI//NF)~~

[Redacted]

~~TOP SECRET//COMINT//NOFORN//MR~~

(d) (TS//SI//NF)

[Redacted]

c. (U//FOUO)

[Redacted]

(b)(3)-P.L. 86-36

(b)(1)
(b)(3)-50 USC 403
(b)(3)-18 USC 798
(b)(3)-P.L. 86-36

(TS//SI)

[Redacted]

d. (U) Assistance to Law Enforcement

(b)(1)
(b)(3)-50 USC 403
(b)(3)-P.L. 86-36
(b)(3)-18 USC 798

(S//SI)

[Redacted]

(b)(3)-P.L. 86-36

e. (U) Working Aids

(U//FOUO) The SID Office of Oversight and Compliance maintains [Redacted]

[Redacted] on its web page for use by the NSA/CSS Enterprise. The E.O., NSA/CSS Policy Number 1-23, DoD Regulation 5240.1-R, and USSID SP0018 are also available on-line.

NSA STAFF PROCESSING FORM

TO DIRECTOR	EXREG CONTROL NUMBER 129769	KCC CONTROL NUMBER IG-10600-06
THRU D/DIR	ACTION <input type="checkbox"/> APPROVAL <input checked="" type="checkbox"/> SIGNATURE <input type="checkbox"/> INFORMATION	EXREG SUSPENSE
SUBJECT (U//FOUO) Quarterly Report to the Intelligence Oversight Board on NSA Activities—First Quarter FY06		KCC SUSPENSE
DISTRIBUTION		ELEMENT SUSPENSE

SUMMARY

PURPOSE: (U//FOUO) To forward to the Intelligence Oversight Board (IOB) of the President's Foreign Intelligence Advisory Board, via the Assistant to the Secretary of Defense for Intelligence Oversight (ATSD(IO)), NSA's quarterly report on its intelligence activities.

BACKGROUND: (U//FOUO) Executive Order 12333 and Executive Order 12863 require Intelligence Community agency heads and Intelligence Community General Counsels and Inspectors General, respectively, to report to the IOB on a quarterly basis concerning intelligence activities that they have reason to believe may be unlawful or contrary to Executive Order or Presidential Directive. The enclosed memorandum covers all reportable activities known to the Inspector General and General Counsel. Per PIOB letter of 6 August 1982, Agency heads are responsible for reporting separately any additional reportable activities known to them, unless the President has specifically instructed that the Board is not to be informed. The Director's signature signifies that no other activities that require reporting are known to him.

RECOMMENDATION: (U) Director sign the enclosed memorandum.

Approved for Release by NSA on 06-01-2009, FOIA Case #49107

This document may be declassified and marked "UNCLASSIFIED//For Official Use Only" upon removal of enclosure(s)

(b) (3) - P.L. 86-36

COORDINATION/APPROVAL					
OFFICE	NAME AND DATE	SECURE PHONE	OFFICE	NAME AND DATE	SECURE PHONE
GC	Robert L. Deitz <i>[Signature]</i> 2/12/06	5548s	DOS	<i>[Signature]</i> 2/24	3201
AGC(O)	<i>[Signature]</i>	3121s			
IG	Joel F. Brenner <i>[Signature]</i>	3544s			
D/IG		3544s			
AIG(IO)	<i>[Signature]</i> 2/13/06	3544s			
ORIGINATOR			ORG. D11	PHONE (Secure) 963-2984	DATE PREPARED 10 February 2006



NATIONAL SECURITY AGENCY
CENTRAL SECURITY SERVICE
FORT GEORGE G. MEADE, MARYLAND 20755-6000

28 February 2006

MEMORANDUM FOR THE CHAIRMAN, INTELLIGENCE OVERSIGHT BOARD

THRU: Assistant to the Secretary of Defense (Intelligence Oversight)

SUBJECT: ~~(U//FOUO)~~ Report to the Intelligence Oversight Board on NSA
Activities - INFORMATION MEMORANDUM

~~(U//FOUO)~~ Except as previously reported to you or the President, or otherwise stated in the enclosure, we have no reason to believe that any intelligence activities of the National Security Agency during the quarter ending 31 December 2005 were unlawful or contrary to Executive Order or Presidential Directive, and thus required to be reported pursuant to Section 1.7.(d) of Executive Order 12333.

~~(U//FOUO)~~ The Inspector General and the General Counsel continue to exercise oversight of Agency activities by means of inspections, surveys, training, review of directives and guidelines, and advice and counsel. These activities and other data requested by the Board or members of the staff of the Assistant to the Secretary of Defense (Intelligence Oversight) are described in the enclosure.

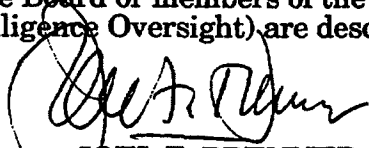
JOEL F. BRENNER
Inspector General

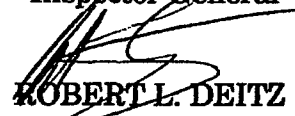
ROBERT L. DEITZ
General Counsel

~~(U//FOUO)~~ I concur in the report of the Inspector General and the General Counsel and hereby make it our combined report.

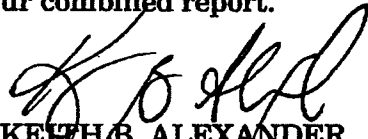
KEITH B. ALEXANDER
Lieutenant General, U. S. Army
Director, NSA/Chief, CSS

Encl:
Quarterly Report

This Memorandum is Unclassified
Upon Removal of Enclosure

DERIVED FROM: NSA/CSSPM 1-52
DATED: 23NOV04
DECLASSIFY ON: 20291123

1. (U) INSPECTOR GENERAL ACTIVITIES

a. ~~(C//SI)~~ During this quarter, the Office of Inspector General (OIG) reviewed various intelligence activities of the National Security Agency/Central Security Service (NSA/CSS) to determine whether they were conducted in accordance with applicable statutes, Executive Orders (E.O.s), Attorney General (AG) procedures, and Department of Defense (DoD) and internal directives. With few exceptions, the issues presented were routine and indicated that the operating elements understand the restrictions on NSA/CSS activities.

b. (U//FOUO) [redacted] the OIG has begun a special study of the access to Signals Intelligence (SIGINT) by [redacted]. The objectives of the special study include determining whether [redacted] that receive SIGINT have the proper authorization to receive SIGINT, have been provided guidance on how to properly handle and use SIGINT, and have adhered to the authority of E.O. 12333 and related directives regarding awareness, protections, and reporting of U.S. person information. The study results will be reported upon completion.

c. (U//FOUO) [redacted]

d. (U//FOUO) [redacted]

e. ~~(C)~~ (U//FOUO) Along with inspectors from [redacted] the NSA OIG completed a joint inspection of the [redacted]

(b)(3)-P.L. 88-36
(b)(1)
(b)(3)-50 USC 403

Derived From: NSA/CSSM 1-52
Dated: 20041123
Declassify On: 20291123

(b)(1)
(b)(3)-P.L. 86-36
(b)(3)-50 USC 403

[Redacted]

Other weaknesses were found in training and program management. NSA/CSS OIG will monitor the deficiencies through correction.

f. (U//FOUO) As reported in the third quarter fiscal year 2005 (report dated 17 may 2005), inspectors from [Redacted]

(b)(3)-P.L. 86-36

[Redacted] the NSA OIG conducted a joint inspection of the [Redacted] Action has been completed to rectify the weakness in its training program, which has been amended to provide intelligence oversight training for personnel who did not have access to the Sensitive Compartmented Information Facility.

(b)(3)-P.L. 86-36

2. (U) GENERAL COUNSEL ACTIVITIES

(C//SI) The NSA/CSS OGC reviewed various intelligence activities of the NSA/CSS to determine whether they were conducted in accordance with applicable statutes, EOs, AG procedures, and DoD and internal directives. The OGC advised Agency elements on a number of questions, including the collection and dissemination of communications of, or concerning U.S. persons; the reporting of possible violations of federal criminal law contained in SIGINT product; the testing of electronic equipment, and the applicability of the Foreign Intelligence Surveillance Act (FISA). With few exceptions, the issues presented were routine and indicated that the operating elements understand the restrictions on NSA/CSS activities.

3. (U) SIGINT ACTIVITIES

a. (S//SI) [Redacted]

(1) (U) [Redacted]

(b)(3)-P.L. 86-36

a. (TS//SI) [Redacted]

(b)(1)-P.L. 86-36

[Redacted]

(b)(1)
(b)(3)-50 USC 403
(b)(3)-18 USC 798
(b)(3)-P.L. 86-36

(b)(3)-P.L. 86-36

b. (S//SI)

[Redacted]

(2) (U)

[Redacted]

(b)(1)
(b)(3)-P.L. 86-36

a. (S//SI/NF)

[Redacted]

[1] (TS//SI/NF)

[Redacted]

[2] (C//SI)

[Redacted]

b. (U//FOUO)

[Redacted]

(b)(3)-P.L. 86-36

(b)(1)
(b)(3)-50 USC 403
(b)(3)-18 USC 798
(b)(3)-P.L. 86-36

(1) (U)

[Redacted]

(a) (S//SI)

[Redacted]

(b)(1)
(b)(3)-P.L. 86-36

(b) (S//SI)

[Redacted]

(b)(1)
(b)(3)-P.L. 86-36

(b)(3)-P.L. 86-36

(b)(1)
(b)(3)-50 USC 403
(b)(3)-P.L. 86-36

(b)(1)
(b)(3)-P.L. 86-36
(b)(3)-50 USC 403

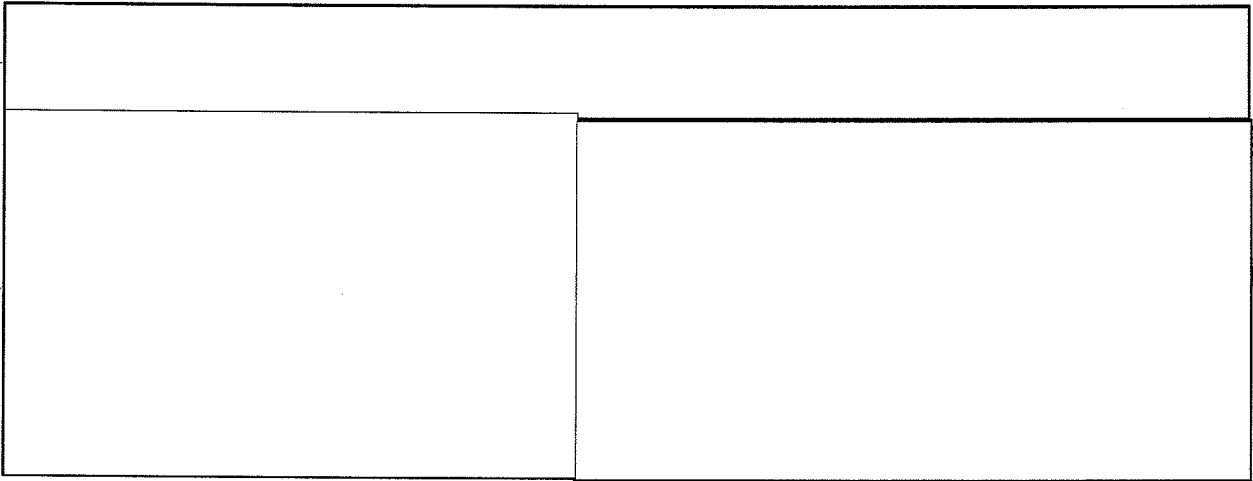

(b)(3)-P.L. 86-36

(b)(1)
(b)(3)-P.L. 86-36

(b)(1)
(b)(3)-50 USC 403
(b)(3)-P.L. 86-36

(2) (U) [Redacted]

(b)(3)-P.L. 86-36

a. (S//SI) [Redacted]

(b)(3)-P.L. 86-36

b. (TS//SI) [Redacted]

c. (TS//SI//NF) [Redacted]

(b)(1)
(b)(3)-50 USC 403
(b)(3)-P.L. 86-36
(b)(3)-18 USC 798

(3) (U) [Redacted]

(b)(3)-P.L. 86-36

(S//SI) [Redacted]

(b)(3)-P.L. 86-36

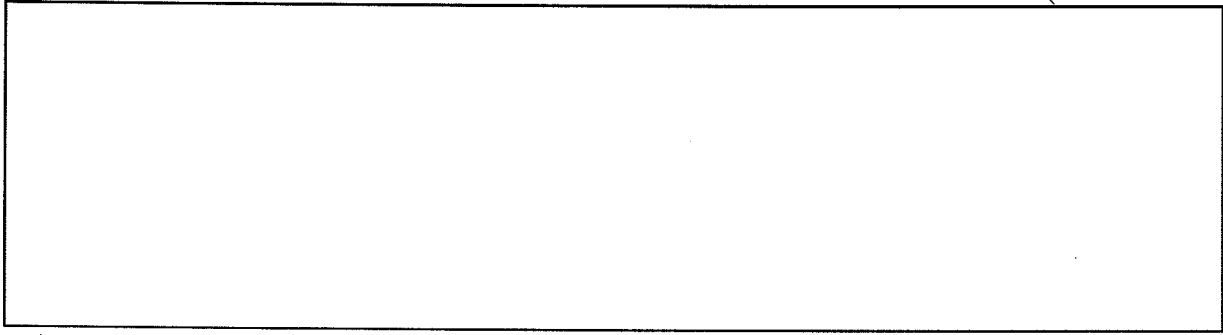

4. (U) Other Activities

a. (U//FOUO)



(b)(3)-P.L. 86-36

(b)(1)
(b)(3)-50 USC 403
(b)(3)-P.L. 86-36
(b)(3)-18 USC 798

(1) (TS//SI//NF)

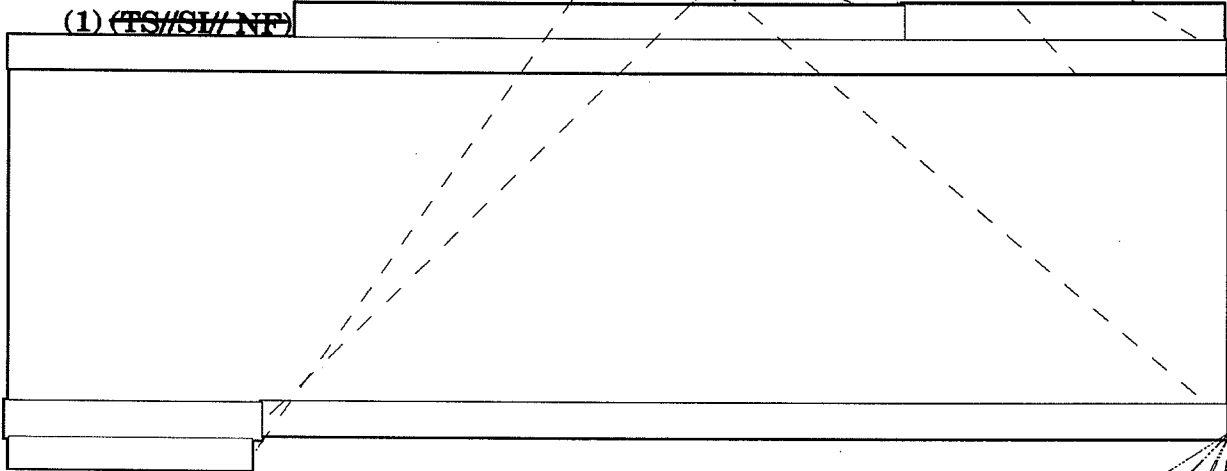

(b)(1)
(b)(3)-50 USC 403
(b)(3)-P.L. 86-36
(b)(3)-18 USC 798

(2) (TS//SI//NF)

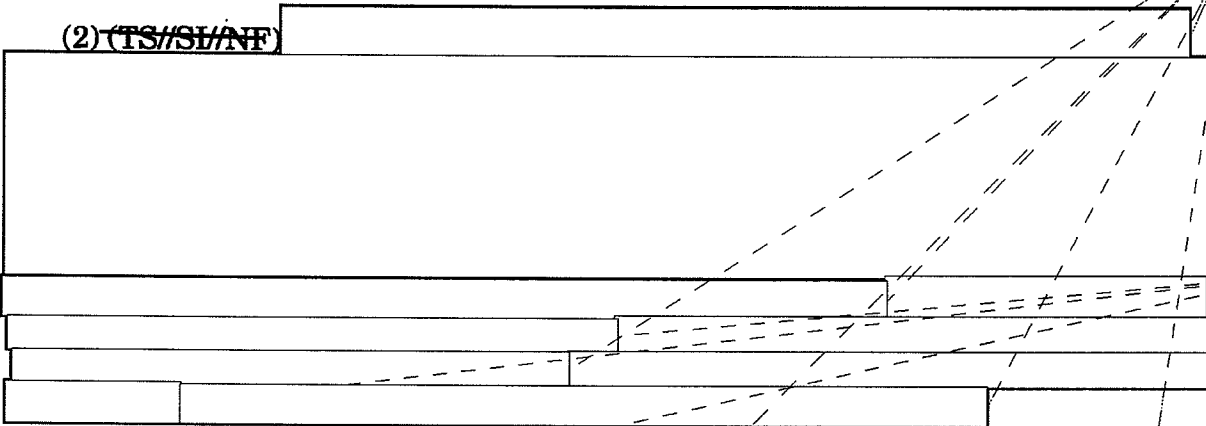

(b)(3)-P.L. 86-36

(3) (TS//SI//NF)

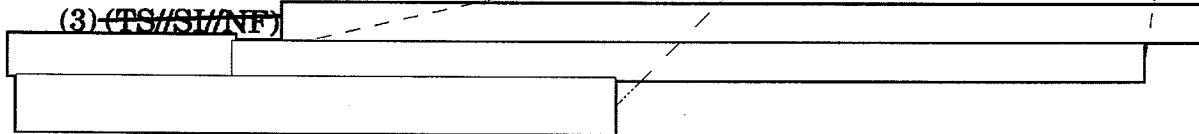

(b)(1)
50 USC 403
(b)(3)-P.L. 86-36
(b)(1) 50 USC 798

(b)(3)-P.L. 86-36

(a) (TS//SI//NF)

[Redacted text block (a)]

(b)(1)
(b)(3)-P.L. 86-36

(b) (TS//SI//NF)

[Redacted text block (b)]

(c) (TS//SI//NF)

[Redacted text block (c)]

(d) (TS//SI//NF)

[Redacted text block (d)]

(b)(3)-P.L. 86-36

(b)(1)
(b)(3)-P.L. 86-36

(4) (TS//SI//NF)

[Redacted text block (4)]

(5) (TS//SI//NF)

[Redacted text block (5)]

[Redacted]

(b)(3)-P.L. 86-36

b. (U//FOUO)

[Redacted]

(b)(1)
(b)(3)-50 USC 403
(b)(3)-P.L. 86-36
(b)(3)-18 USC 798

~~(S)~~

[Redacted]

(b)(1)
(b)(3)-P.L. 86-36

c. (U//FOUO)

[Redacted]

~~(TS//SI//NF)~~

[Redacted]

(b)(3)-P.L. 86-36

d. (U) Assistance to Law Enforcement

~~(S//SI)~~

[Redacted]

(b)(3)-P.L. 86-36

(b)(3)-P.L. 86-36

e. (U) Working Aids

(1) (U//FOUO) The SID Office of Oversight and Compliance maintains [Redacted] on its web page for use by the NSA/CSS Enterprise. The E.O., NSA/CSS Policy Number 1-23, DoD Regulation 5240.1-R, and USSID SP0018 are also available on-line.

(2) (U//FOUO) The NSA/CSS NTOC created and implemented Standard Operating Procedures (SOP) governing SIGINT and Information Assurance activities for the NTOC [Redacted]. The SOP contains handling and reporting procedures governing the NTOC activities that affect U. S. Persons.