



FAA FORM 8130-6, APPLICATION FOR U.S. AIRWORTHINESS CERTIFICATE

Form Approved
O.M.B. No. 2120-0018
Exp. date: 12/31/2010

 U.S. Department of Transportation Federal Aviation Administration		APPLICATION FOR U.S. AIRWORTHINESS CERTIFICATE		INSTRUCTIONS - Print or type. Do not write in shaded areas; these are for FAA use only. Submit original only to an authorized FAA Representative. If additional space is required, use attachment. For special flight permits complete Sections II, VI and VII as applicable.																																																																																																																																																																										
I. AIRCRAFT DESIGNATION	1. REGISTRATION MARK	2. AIRCRAFT BUILDER'S NAME (Make)	3. AIRCRAFT MODEL DESIGNATION	4. YR. MFR	FAA CODING																																																																																																																																																																									
	N6542B	Blackwater Airships, LLC	Polar 400	2007																																																																																																																																																																										
	5. AIRCRAFT SERIAL NO.	6. ENGINE BUILDER'S NAME (Make)	7. ENGINE MODEL DESIGNATION																																																																																																																																																																											
	400-001	Thielert Aircraft Engines	Centurian 4.0																																																																																																																																																																											
II. CERTIFICATION REQUESTED	8. NUMBER OF ENGINES	9. PROPELLER BUILDER'S NAME (Make)	10. PROPELLER MODEL DESIGNATION	11. AIRCRAFT IS (Check if applicable)																																																																																																																																																																										
	1 (One)	MT-Propeller GmbH	MTV-6-A-CR(H)/CRRD175-05	IMPORT																																																																																																																																																																										
APPLICATION IS HEREBY MADE FOR: (Check applicable items)																																																																																																																																																																														
<table border="1"> <tr> <td>A</td> <td>1</td> <td>STANDARD AIRWORTHINESS CERTIFICATE (Indicate Category)</td> <td>NORMAL</td> <td>UTILITY</td> <td>ACROBATIC</td> <td>TRANSPORT</td> <td>COMMUTER</td> <td>BALLOON</td> <td>OTHER</td> </tr> <tr> <td>B</td> <td></td> <td>SPECIAL AIRWORTHINESS CERTIFICATE (Check appropriate items)</td> <td colspan="7"></td> </tr> <tr> <td rowspan="15"></td> <td>7</td> <td>PRIMARY</td> <td colspan="7"></td> </tr> <tr> <td>9</td> <td>LIGHT-SPORT (Indicate Class)</td> <td>AIRPLANE</td> <td>POWER-PARACHUTE</td> <td>WEIGHT-SHIFT-CONTROL</td> <td>GLIDER</td> <td>LIGHTER THAN AIR</td> <td colspan="3"></td> </tr> <tr> <td>2</td> <td>LIMITED</td> <td colspan="7"></td> </tr> <tr> <td rowspan="2">5</td> <td rowspan="2">PROVISIONAL (Indicate Class)</td> <td>1</td> <td>CLASS I</td> <td colspan="6"></td> </tr> <tr> <td>2</td> <td>CLASS II</td> <td colspan="6"></td> </tr> <tr> <td rowspan="4">3</td> <td rowspan="4">RESTRICTED (Indicate operation(s) to be conducted)</td> <td>1</td> <td>AGRICULTURE AND PEST CONTROL</td> <td>2</td> <td>AERIAL SURVEY</td> <td>3</td> <td>AERIAL ADVERTISING</td> <td colspan="3"></td> </tr> <tr> <td>4</td> <td>FOREST (Wildlife Conservation)</td> <td>5</td> <td>PATROLLING</td> <td>6</td> <td>WEATHER CONTROL</td> <td colspan="3"></td> </tr> <tr> <td>0</td> <td>OTHER (Specify)</td> <td colspan="5"></td> </tr> <tr> <td>4</td> <td rowspan="4">EXPERIMENTAL (Indicate operation(s) to be conducted)</td> <td>1</td> <td>RESEARCH AND DEVELOPMENT</td> <td>2</td> <td>AMATEUR BUILT</td> <td>3</td> <td>EXHIBITION</td> <td colspan="3"></td> </tr> <tr> <td>4</td> <td>AIR RACING</td> <td>5</td> <td>CREW TRAINING</td> <td>6</td> <td>MARKET SURVEY</td> <td colspan="3"></td> </tr> <tr> <td>0</td> <td>TO SHOW COMPLIANCE WITH THE CFR</td> <td>7</td> <td>OPERATING (Primary Category) KIT BUILT AIRCRAFT</td> <td colspan="4"></td> </tr> <tr> <td>8</td> <td>OPERATING LIGHT-SPORT</td> <td>8A</td> <td>Existing Aircraft without an airworthiness certificate & do not meet § 103.1</td> <td colspan="4"></td> </tr> <tr> <td rowspan="6">8</td> <td rowspan="6">SPECIAL FLIGHT PERMIT (Indicate operation(s) to be conducted, then complete Section VI or VII as applicable on reverse side)</td> <td>1</td> <td>FERRY FLIGHT FOR REPAIRS, ALTERATIONS, MAINTENANCE, OR STORAGE</td> <td colspan="4"></td> </tr> <tr> <td>2</td> <td>EVACUATION FROM AREA OF IMPENDING DANGER</td> <td colspan="4"></td> </tr> <tr> <td>3</td> <td>OPERATION IN EXCESS OF MAXIMUM CERTIFICATED TAKE-OFF WEIGHT</td> <td colspan="4"></td> </tr> <tr> <td>4</td> <td>DELIVERING OR EXPORTING</td> <td>5</td> <td>PRODUCTION FLIGHT TESTING</td> <td colspan="3"></td> </tr> <tr> <td>6</td> <td>CUSTOMER DEMONSTRATION FLIGHTS</td> <td colspan="4"></td> </tr> <tr> <td>6</td> <td>MULTIPLE AIRWORTHINESS CERTIFICATE (check ABOVE "Restricted Operation" and "Standard" or "Limited" as applicable)</td> <td colspan="4"></td> </tr> </table>						A	1	STANDARD AIRWORTHINESS CERTIFICATE (Indicate Category)	NORMAL	UTILITY	ACROBATIC	TRANSPORT	COMMUTER	BALLOON	OTHER	B		SPECIAL AIRWORTHINESS CERTIFICATE (Check appropriate items)									7	PRIMARY								9	LIGHT-SPORT (Indicate Class)	AIRPLANE	POWER-PARACHUTE	WEIGHT-SHIFT-CONTROL	GLIDER	LIGHTER THAN AIR				2	LIMITED								5	PROVISIONAL (Indicate Class)	1	CLASS I							2	CLASS II							3	RESTRICTED (Indicate operation(s) to be conducted)	1	AGRICULTURE AND PEST CONTROL	2	AERIAL SURVEY	3	AERIAL ADVERTISING				4	FOREST (Wildlife Conservation)	5	PATROLLING	6	WEATHER CONTROL				0	OTHER (Specify)						4	EXPERIMENTAL (Indicate operation(s) to be conducted)	1	RESEARCH AND DEVELOPMENT	2	AMATEUR BUILT	3	EXHIBITION				4	AIR RACING	5	CREW TRAINING	6	MARKET SURVEY				0	TO SHOW COMPLIANCE WITH THE CFR	7	OPERATING (Primary Category) KIT BUILT AIRCRAFT					8	OPERATING LIGHT-SPORT	8A	Existing Aircraft without an airworthiness certificate & do not meet § 103.1					8	SPECIAL FLIGHT PERMIT (Indicate operation(s) to be conducted, then complete Section VI or VII as applicable on reverse side)	1	FERRY FLIGHT FOR REPAIRS, ALTERATIONS, MAINTENANCE, OR STORAGE					2	EVACUATION FROM AREA OF IMPENDING DANGER					3	OPERATION IN EXCESS OF MAXIMUM CERTIFICATED TAKE-OFF WEIGHT					4	DELIVERING OR EXPORTING	5	PRODUCTION FLIGHT TESTING				6	CUSTOMER DEMONSTRATION FLIGHTS					6	MULTIPLE AIRWORTHINESS CERTIFICATE (check ABOVE "Restricted Operation" and "Standard" or "Limited" as applicable)				
A	1	STANDARD AIRWORTHINESS CERTIFICATE (Indicate Category)	NORMAL	UTILITY	ACROBATIC	TRANSPORT	COMMUTER	BALLOON	OTHER																																																																																																																																																																					
B		SPECIAL AIRWORTHINESS CERTIFICATE (Check appropriate items)																																																																																																																																																																												
	7	PRIMARY																																																																																																																																																																												
	9	LIGHT-SPORT (Indicate Class)	AIRPLANE	POWER-PARACHUTE	WEIGHT-SHIFT-CONTROL	GLIDER	LIGHTER THAN AIR																																																																																																																																																																							
	2	LIMITED																																																																																																																																																																												
	5	PROVISIONAL (Indicate Class)	1	CLASS I																																																																																																																																																																										
			2	CLASS II																																																																																																																																																																										
	3	RESTRICTED (Indicate operation(s) to be conducted)	1	AGRICULTURE AND PEST CONTROL	2	AERIAL SURVEY	3	AERIAL ADVERTISING																																																																																																																																																																						
			4	FOREST (Wildlife Conservation)	5	PATROLLING	6	WEATHER CONTROL																																																																																																																																																																						
			0	OTHER (Specify)																																																																																																																																																																										
			4	EXPERIMENTAL (Indicate operation(s) to be conducted)	1	RESEARCH AND DEVELOPMENT	2	AMATEUR BUILT	3	EXHIBITION																																																																																																																																																																				
	4	AIR RACING	5		CREW TRAINING	6	MARKET SURVEY																																																																																																																																																																							
	0	TO SHOW COMPLIANCE WITH THE CFR	7		OPERATING (Primary Category) KIT BUILT AIRCRAFT																																																																																																																																																																									
	8	OPERATING LIGHT-SPORT	8A		Existing Aircraft without an airworthiness certificate & do not meet § 103.1																																																																																																																																																																									
	8	SPECIAL FLIGHT PERMIT (Indicate operation(s) to be conducted, then complete Section VI or VII as applicable on reverse side)	1	FERRY FLIGHT FOR REPAIRS, ALTERATIONS, MAINTENANCE, OR STORAGE																																																																																																																																																																										
			2	EVACUATION FROM AREA OF IMPENDING DANGER																																																																																																																																																																										
			3	OPERATION IN EXCESS OF MAXIMUM CERTIFICATED TAKE-OFF WEIGHT																																																																																																																																																																										
4			DELIVERING OR EXPORTING	5	PRODUCTION FLIGHT TESTING																																																																																																																																																																									
6			CUSTOMER DEMONSTRATION FLIGHTS																																																																																																																																																																											
6			MULTIPLE AIRWORTHINESS CERTIFICATE (check ABOVE "Restricted Operation" and "Standard" or "Limited" as applicable)																																																																																																																																																																											
III. OWNER'S CERTIFICATION	A. REGISTERED OWNER (As shown on certificate of aircraft registration)		IF DEALER, CHECK HERE →																																																																																																																																																																											
	NAME Blackwater Airships, LLC		ADDRESS PO Box 1029, Moyock NC 27958-1029																																																																																																																																																																											
	B. AIRCRAFT CERTIFICATION BASIS (Check applicable blocks and complete items as indicated)																																																																																																																																																																													
	AIRCRAFT SPECIFICATION OR TYPE CERTIFICATE DATA SHEET (Give No. and Revision No.) N/A		AIRWORTHINESS DIRECTIVES (Check if all applicable AD's are complied with and give the number of the last AD SUPPLEMENT available in the biweekly series as of the date of application) N/A																																																																																																																																																																											
	AIRCRAFT LISTING (Give page number(s)) N/A		SUPPLEMENTAL TYPE CERTIFICATE (List number of each STC incorporated) N/A																																																																																																																																																																											
C. AIRCRAFT OPERATION AND MAINTENANCE RECORDS																																																																																																																																																																														
CHECK IF RECORDS IN COMPLIANCE WITH 14 CFR Section 91.417		TOTAL AIRFRAME HOURS 299.0		EXPERIMENTAL ONLY (Enter hours flown since last certificate issued or renewed) 299.0																																																																																																																																																																										
D. CERTIFICATION - I hereby certify that I am the registered owner (or his agent) of the aircraft described above, that the aircraft is registered with the Federal Aviation Administration in accordance with Title 49 of the United States Code 44101 et seq. and applicable Federal Aviation Regulations, and that the aircraft has been inspected and is airworthy and eligible for the airworthiness certificate requested.																																																																																																																																																																														
DATE OF APPLICATION April 15, 2010		NAME AND TITLE (Print or type) Alan Ram (Vice President)		SIGNATURE 																																																																																																																																																																										
IV. INSPECTION AGENCY VERIFICATION	A. THE AIRCRAFT DESCRIBED ABOVE HAS BEEN INSPECTED AND FOUND AIRWORTHY BY: (Complete the section only if 14 CFR part 21.163(d) applies)																																																																																																																																																																													
	2	14 CFR part 121 CERTIFICATE HOLDER (Give Certificate No.)	3	CERTIFICATED MECHANIC (Give Certificate No.)	6	CERTIFICATED REPAIR STATION (Give Certificate No.)																																																																																																																																																																								
	5	AIRCRAFT MANUFACTURER (Give name or firm)																																																																																																																																																																												
DATE		TITLE		SIGNATURE																																																																																																																																																																										
V. FAA REPRESENTATIVE CERTIFICATION	(Check ALL applicable block items A and B)																																																																																																																																																																													
	A. I find that the aircraft described in Section I or VII meets requirements for			THE CERTIFICATE REQUESTED																																																																																																																																																																										
	B. Inspection for a special permit under Section VII was conducted by:			AMENDMENT OR MODIFICATION OF CURRENT AIRWORTHINESS CERTIFICATE																																																																																																																																																																										
				4																																																																																																																																																																										
DATE MAY 10, 2010		DISTRICT OFFICE Atlanta MIDO		DESIGNEE'S SIGNATURE AND NO. J. Henson. DARE 501107CE																																																																																																																																																																										
				FAA INSPECTOR'S SIGNATURE																																																																																																																																																																										



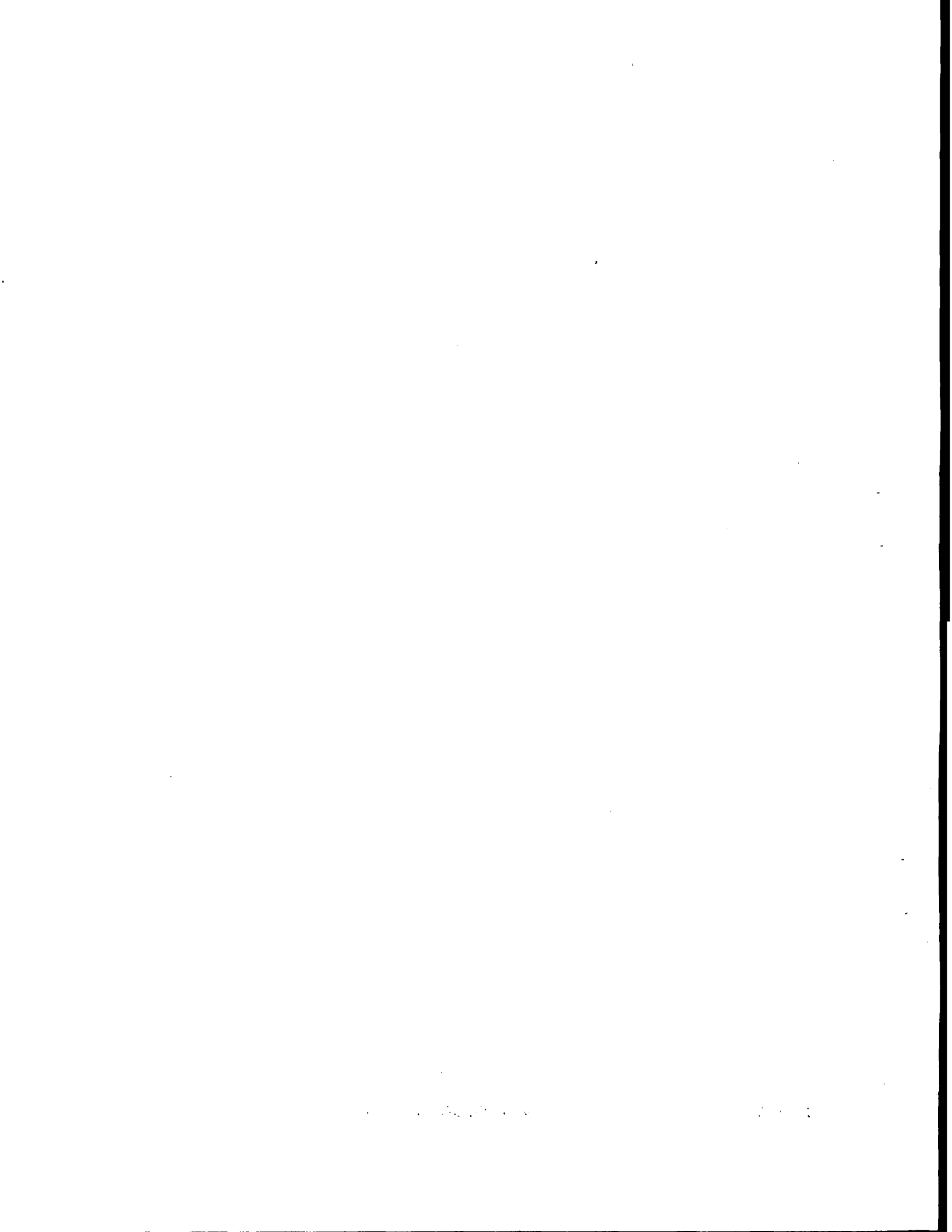
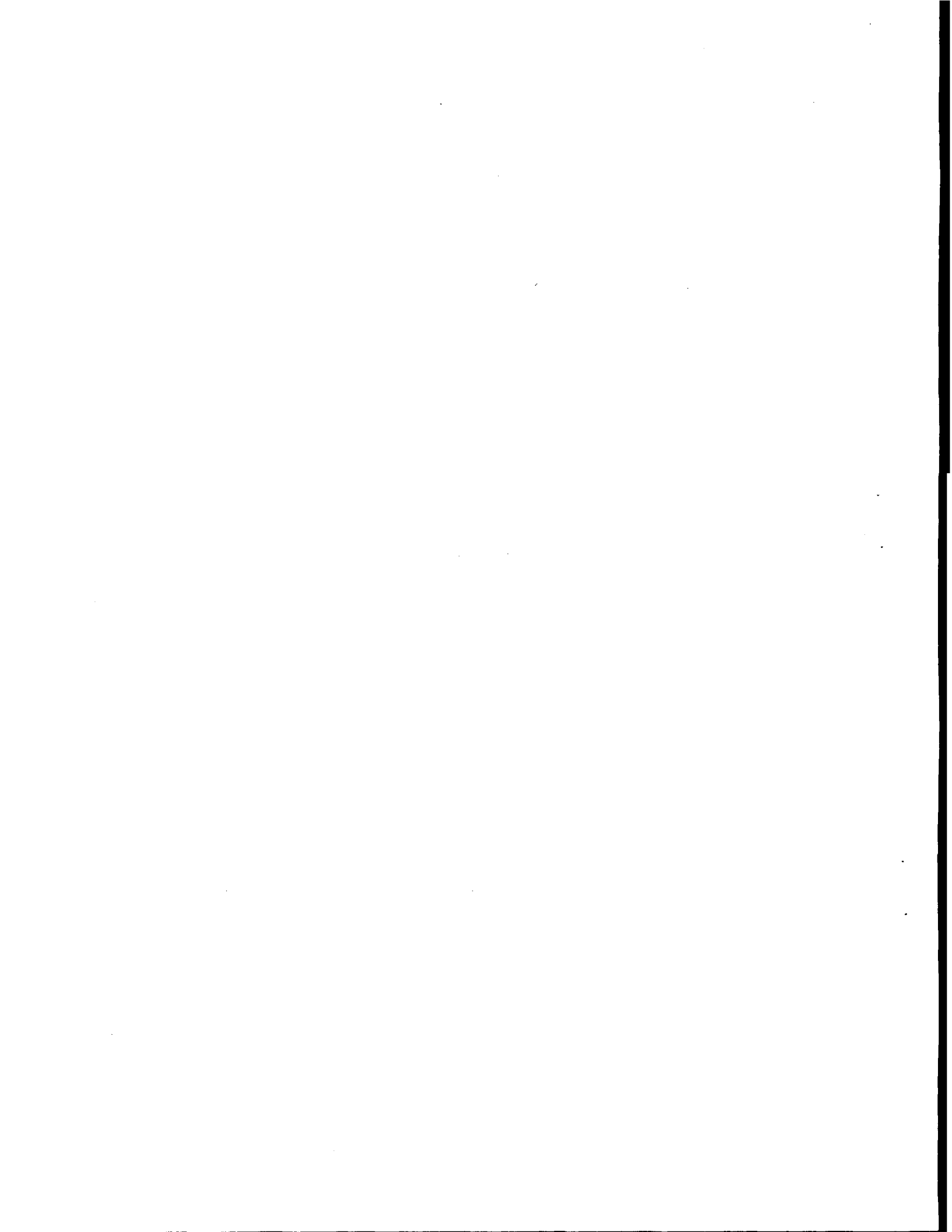

UNITED STATES OF AMERICA
DEPARTMENT OF TRANSPORTATION - FEDERAL AVIATION ADMINISTRATION
SPECIAL AIRWORTHINESS CERTIFICATE

A	CATEGORY/DESIGNATION EXPERIMENTAL	
	PURPOSE RESEARCH AND DEVELOPMENT	
B	MANU-FACTURER	NAME N/A
		ADDRESS N/A
C	FLIGHT	FROM N/A
		TO N/A
D	N- 6542B	SERIAL NO. 400-01
	BUILDER BLACKWATER AIRSHIPS LLC	MODEL POLAR 400
	DATE OF ISSUANCE MAY 10, 2010	EXPIRY NOV 9, 2010
E	OPERATING LIMITATIONS DATED MAY 10, 2010 ARE A PART OF THIS CERTIFICATE	
	SIGNATURE OF FAA REPRESENTATIVE  John Hankinson	DESIGNATION OR OFFICE NO. DARF501107CE

Any alteration, reproduction or misuse of this certificate may be punishable by a fine not exceeding \$1,000 or imprisonment not exceeding 3 years, or both. THIS CERTIFICATE MUST BE DISPLAYED IN THE AIRCRAFT IN ACCORDANCE WITH APPLICABLE FEDERAL AVIATION REGULATIONS.

A	This airworthiness certificate is issued under the authority of the Federal Aviation Act of 1958 and the Federal Aviation Regulations (FAR).
B	This airworthiness certificate authorizes the manufacturer named on the reverse side to conduct production flight tests, and only production flight tests, of aircraft registered in his name. No person may conduct production flight tests under this certificate: (1) Carrying persons or property for compensation or hire; and/or (2) Carrying persons not essential to the purpose of the flight.
C	This airworthiness certificate authorizes the flight specified on the reverse side for the purpose shown in Block A.
D	This airworthiness certificate certifies that, as of the date of issuance, the aircraft to which issued has been inspected and found to meet the requirements of the applicable FAR. The aircraft does not meet the requirements of the applicable comprehensive and detailed airworthiness code as provided by Annex 8 to the Convention On International Civil Aviation. No person may operate the aircraft described on the reverse side: (1) except in accordance with the applicable FAR and in accordance with conditions and limitations which may be prescribed by the Administrator as part of this certificate; (2) over any foreign country without the special permission of that country.
E	Unless sooner surrendered, suspended, or revoked, this airworthiness certificate is effective for the duration and under the conditions prescribed in FAR Part 21, Section 21.181 or 21.217.

UNITED STATES OF AMERICA
 DEPARTMENT OF TRANSPORTATION - FEDERAL AVIATION ADMINISTRATION
SPECIAL AIRWORTHINESS CERTIFICATE

A	CATEGORY/DESIGNATION	EXPERIMENTAL	
	PURPOSE	RESEARCH AND DEVELOPMENT	
B	MANU-FACTURER	NAME	N/A
		ADDRESS	N/A
C	FLIGHT	FROM	N/A
		TO	N/A
D	N- 6542B		SERIAL NO. 400-01
	BUILDER BLACKWATER AIRSHIPS LLC		MODEL POLAR 400
E	DATE OF ISSUANCE NOV 9, 2009		EXPIRY MAY 8, 2010
	OPERATING LIMITATIONS DATED		ARE A PART OF THIS CERTIFICATE
	SIGNATURE OF FAA REPRESENTATIVE		DESIGNATION OR OFFICE NO.
J HANKINSON <i>J. Hankinson</i>		DARE501107CE	

Any alteration, reproduction or misuse of this certificate may be punishable by a fine not exceeding \$1,000 or imprisonment not exceeding 3 years, or both. THIS CERTIFICATE MUST BE DISPLAYED IN THE AIRCRAFT IN ACCORDANCE WITH APPLICABLE FEDERAL AVIATION REGULATIONS.

A	This airworthiness certificate is issued under the authority of the Federal Aviation Act of 1958 and the Federal Aviation Regulations (FAR).
B	This airworthiness certificate authorizes the manufacturer named on the reverse side to conduct production flight tests, and only production flight tests, of aircraft registered in his name. No person may conduct production flight tests under this certificate: (1) Carrying persons or property for compensation or hire; and/or (2) Carrying persons not essential to the purpose of the flight.
C	This airworthiness certificate authorizes the flight specified on the reverse side for the purpose, shown in Block A.
D	This airworthiness certificate certifies that, as of the date of issuance, the aircraft to which issued has been inspected and found to meet the requirements of the applicable FAR. The aircraft does not meet the requirements of the applicable comprehensive and detailed airworthiness code as provided by Annex 8 to the Convention On International Civil Aviation. No person may operate the aircraft described on the reverse side: (1) except in accordance with the applicable FAR and in accordance with conditions and limitations which may be prescribed by the Administrator as part of this certificate; (2) over any foreign country without the special permission of that country.
E	Unless sooner surrendered, suspended, or revoked, this airworthiness certificate is effective for the duration and under the conditions prescribed in FAR Part 21, Section 21.181 or 21.217.



U.S. Department
of Transportation

**Federal Aviation
Administration**

**SPECIAL
EXPERIMENTAL
RESEARCH and DEVELOPMENT
OPERATING LIMITATIONS**

MAKE: Blackwater Airships, LLC

MODEL: Polar 400

SERIAL NUMBER: 400-001

REG. NUMBER: N6542B

Date Issued: May 10, 2010

Expiration Date: Nov 9, 2010

- 1) No person may operate this aircraft unless Form 8130-7 is displayed at the cockpit entrance and visible to flight crew members.
- 2) No person may operate this aircraft for other than the purpose of Research and Development, to accomplish the flight operation outlined in the program letter dated April 15, 2010, which describes compliance with §21.193(d), and has been made available to the pilot in command of the aircraft. In addition, this aircraft must be operated in accordance with applicable air traffic and general operating rules of part 91, and all additional limitations herein prescribed under provisions of §91.319(e).
- 3) All flights of this aircraft must be conducted over open water or sparsely populated areas having light air traffic, within the geographic area described as follows: Within 150 nautical mile radius of the former Weeksville, NC Naval Air Station (EKV) 36°13'59.19"N, 76°08'0.01"W.
- 4) This aircraft must not be operated unless it is inspected and maintained in accordance with the manufacturers recommendations. The owner/operator must select, establish, identify, and use an inspection program as set forth in §91.409(e), (f), (g) and (h). This inspection program must be recorded in the aircraft maintenance records.
- 5) The pilot in command of this aircraft must hold an appropriate category/class rating. If required for the type of aircraft to be flown, the pilot in command also must hold either an appropriate type rating or a letter of authorization issued by an FAA Flight Standards Operations Inspector.
- 6) This aircraft is to be operated under VFR, day and/or night.
- 7) No person may operate this aircraft for carrying persons or property for compensation or hire.
- 8) No person may be carried in this aircraft during flight unless that person is essential to the purpose of the flight.
- 9) The pilot in command of this aircraft must advise each passenger of the experimental nature of this aircraft, and explain that it does not meet the certification requirements of a standard certificated aircraft.

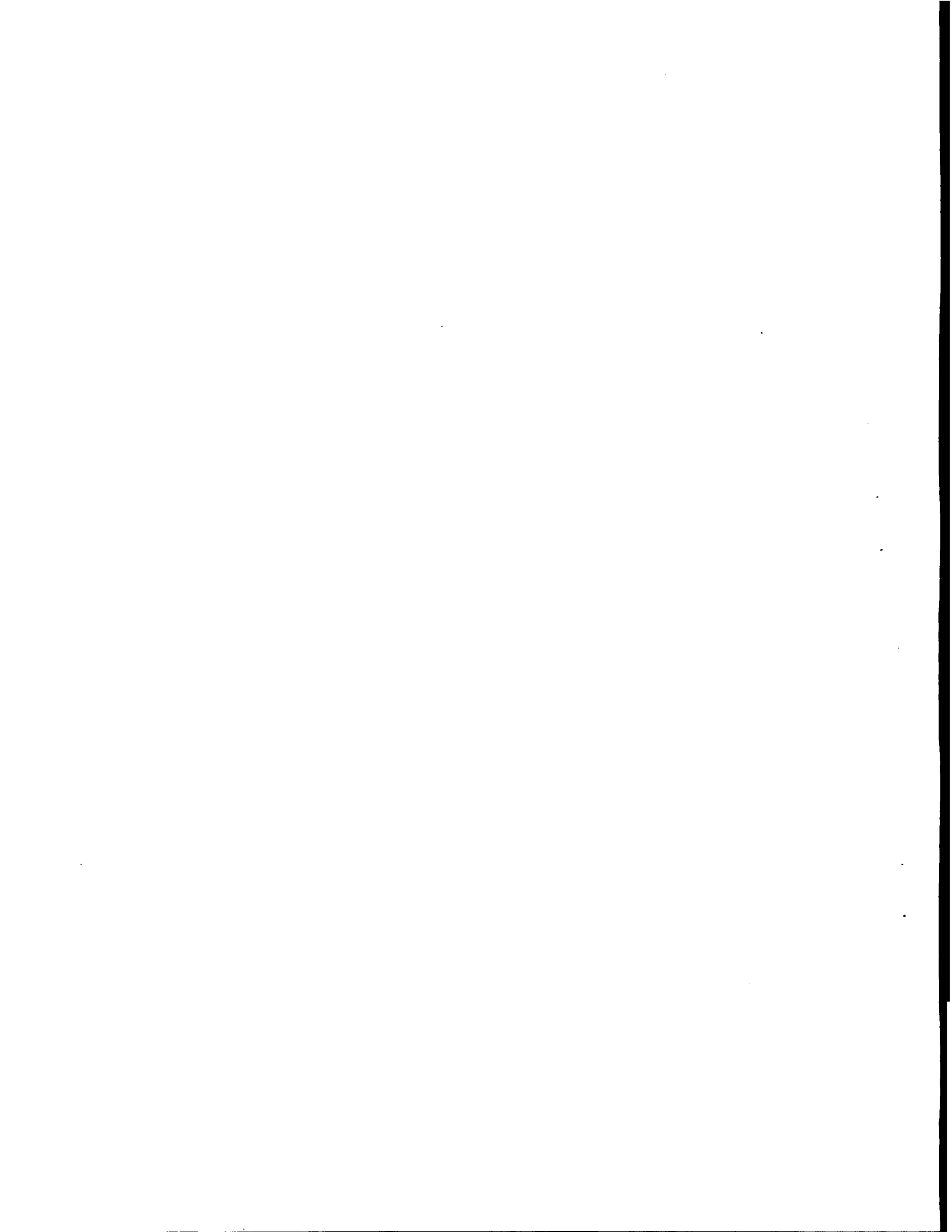

- 10) This aircraft must contain the placards, markings, etc. required by §91.9(c).
- 11) This aircraft is prohibited from aerobatic flight, that is, an intentional maneuver involving an abrupt change in the aircraft's attitude, an abnormal attitude, or abnormal acceleration not necessary for normal flight.
- 12) No person may operate this aircraft unless within the preceding 12 calendar months it has had a condition inspection performed in accordance with appendix D of part 43, or other FAA approved program, and was found to be in a condition for safe operation. This inspection will be recorded in the aircraft maintenance records.
- 13) Only FAA certificated mechanics with appropriate ratings as authorized by §43.3 may perform inspections required by these operating limitations.
- 14) Inspections must be recorded in the aircraft maintenance records showing the following, or a similar worded statement: " I certify that this aircraft has been inspected on [insert date] in accordance with the scope and detail of appendix D to part 43, or other FAA approved program, and was found to be in a condition of safe operation." The entry will include the aircraft's total time-in-service, and the name, signature, certificate held by the person performing the inspection.
- 15) This aircraft must display the word "EXPERIMENTAL" in accordance with §45.23(b).
- 16) The pilot in command of this aircraft must notify air traffic control of the experimental nature of this aircraft when operating into or out of airports with operating control towers. The pilot in command must plan routing that will avoid densely populated areas and congested airways when operating VFR.
- 17) Aircraft instruments and equipment installed and used under §91.205 must be inspected and maintained in accordance with the requirements of parts 43 and 91. Any maintenance or inspection of this equipment must be recorded in the aircraft maintenance records.
- 18) Application must be made to the Atlanta MIDO for any revision to these operating limitations.
- 19) Section §47.45 requires that the FAA Aircraft Registry must be notified within 30 days of any change in the aircraft registrant's address. Such notification is to be made by submitting Form 8050-1 to AFS-750 in Oklahoma City, Oklahoma.

May 10, 2010
Date

J. Hankinson
FAA Representative

John Hankinson

DARF501107CE
Designation

These operating Limitations have been explained, are understood and accepted

May 10, 2010
Date

John M. Saffer
Pilot in Command

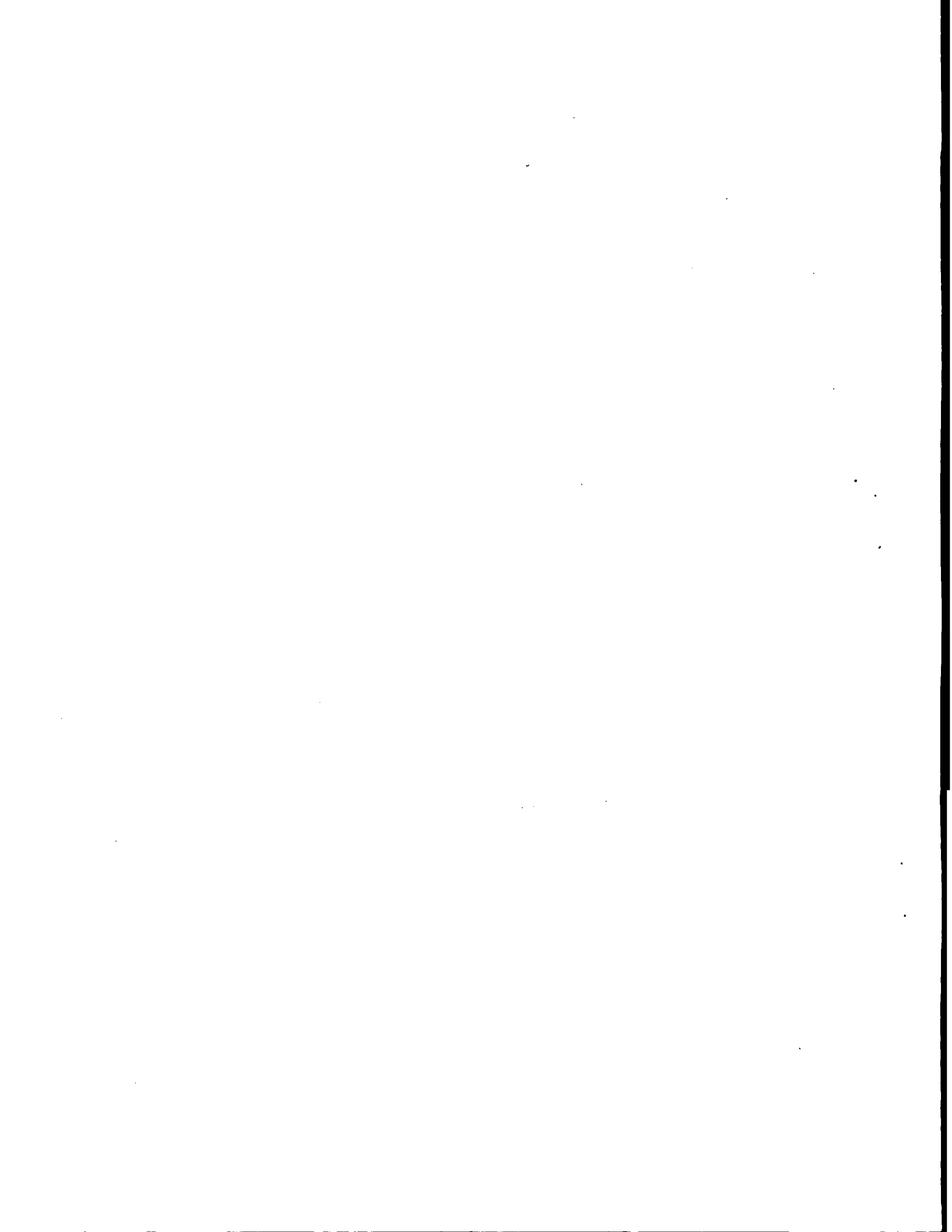

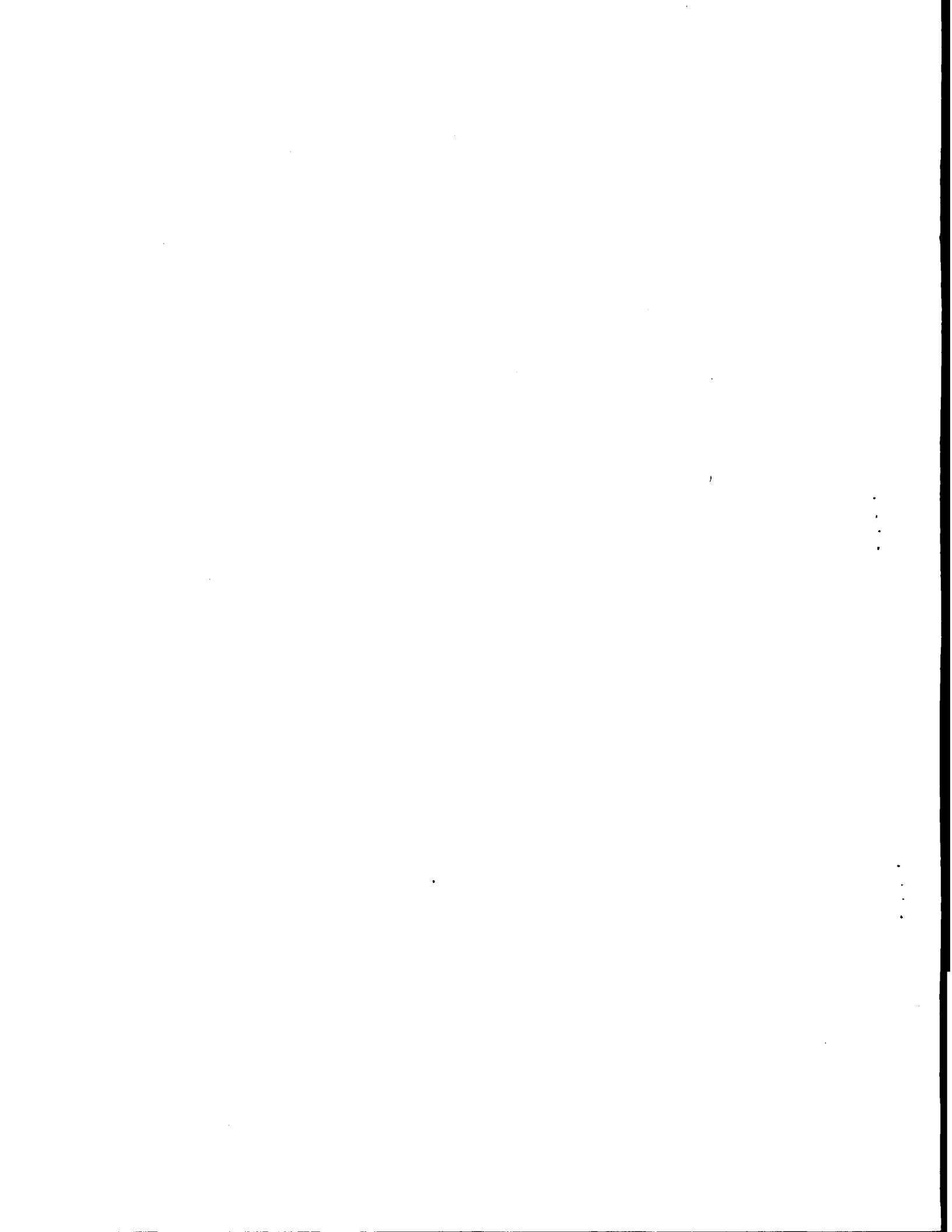

FAA FORM 8130-6, APPLICATION FOR U.S. AIRWORTHINESS CERTIFICATE

Form Approved
O.M.B. No. 2120-0018
Exp. date: 12/31/2010

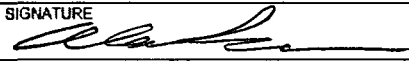
 U.S. Department of Transportation Federal Aviation Administration		APPLICATION FOR U.S. AIRWORTHINESS CERTIFICATE		INSTRUCTIONS - Print or type. Do not write in shaded areas, these are for FAA use only. Submit original only to an authorized FAA Representative. If additional space is required, use attachment. For special flight permits complete Sections II, VI and VII as applicable.								
I. AIRCRAFT DESIGNATION	1. REGISTRATION MARK	2. AIRCRAFT BUILDER'S NAME (Make)	3. AIRCRAFT MODEL DESIGNATION	4. YR. MFR.	FAA CODING							
	N6542B	Blackwater Airships, LLC	Polar 400	2007								
	5. AIRCRAFT SERIAL NO.	6. ENGINE BUILDER'S NAME (Make)	7. ENGINE MODEL DESIGNATION									
	400-001	Thielert Aircraft Engines	Centurion 4.0									
I. AIRCRAFT DESIGNATION	8. NUMBER OF ENGINES	9. PROPELLER BUILDER'S NAME (Make)	10. PROPELLER MODEL DESIGNATION	11. AIRCRAFT IS (Check if applicable)								
	1 (One)	MT-Propeller GmbH	MTV-6-A-CR(H)/CRRD175-05	IMPORT								
APPLICATION IS HEREBY MADE FOR: (Check applicable items)												
II. CERTIFICATION REQUESTED	A: 1	STANDARD AIRWORTHINESS CERTIFICATE (Indicate Category)		NORMAL	UTILITY	ACROBATIC	TRANSPORT	COMMUTER	BALLOON	OTHER		
	B: 1	SPECIAL AIRWORTHINESS CERTIFICATE (Check appropriate items)										
	7:	PRIMARY										
		9:	LIGHT-SPORT (Indicate Class)		AIRPLANE	POWER-PARACHUTE	WEIGHT-SHIFT-CONTROL	GLIDER	LIGHTER THAN AIR			
	2:	LIMITED										
	5:	PROVISIONAL (Indicate Class)		1:	CLASS I							
				2:	CLASS II							
	3:	RESTRICTED (Indicate operation(s) to be conducted)		1:	AGRICULTURE AND PEST CONTROL		2:	AERIAL SURVEY		3:	AERIAL ADVERTISING	
				4:	FOREST (Wildlife Conservation)		5:	PATROLLING		6:	WEATHER CONTROL	
				0:	OTHER (Specify)							
	4:	EXPERIMENTAL (Indicate operation(s) to be conducted)		1:	RESEARCH AND DEVELOPMENT		2:	AMATEUR BUILT		3:	EXHIBITION	
				4:	AIR RACING		5:	CREW TRAINING		6:	MARKET SURVEY	
		0:	TO SHOW COMPLIANCE WITH THE CFR		7:	OPERATING (Primary Category) KIT BUILT AIRCRAFT						
		8:	OPERATING LIGHT-SPORT		8A:	Existing Aircraft without an airworthiness certificate & do not meet § 103.1						
					8B:	Operating Light-Sport Kit-Built						
					8C:	Operating light-sport previously issued special light-sport category airworthiness certificate under § 21.100						
8:	SPECIAL FLIGHT PERMIT (Indicate operation(s) to be conducted, then complete Section VI or VII as applicable on reverse side)		1:	FERRY FLIGHT FOR REPAIRS, ALTERATIONS, MAINTENANCE, OR STORAGE								
			2:	EVACUATION FROM AREA OF IMPENDING DANGER								
			3:	OPERATION IN EXCESS OF MAXIMUM CERTIFICATED TAKE-OFF WEIGHT								
			4:	DELIVERING OR EXPORTING		5:	PRODUCTION FLIGHT TESTING					
			6:	CUSTOMER DEMONSTRATION FLIGHTS								
			6:	MULTIPLE AIRWORTHINESS CERTIFICATE (check ABOVE "Restricted Operation" and "Standard" or "Limited" as applicable)								
III. OWNER'S CERTIFICATION	A. REGISTERED OWNER (As shown on certificate of aircraft registration)		IF DEALER, CHECK HERE									
	NAME		ADDRESS									
	Blackwater Airships, LLC		PO Box 1029, Moyock NC 27958-1029									
	B. AIRCRAFT CERTIFICATION BASIS (Check applicable blocks and complete items as indicated)		AIRCRAFT SPECIFICATION OR TYPE CERTIFICATE DATA SHEET (Give No. and Revision No.)		AIRCRAFT LISTING (Give page number(s))		AIRCRAFT CERTIFICATION BASIS		AIRCRAFT LISTING (Give page number(s))			
	N/A		N/A		N/A		N/A		N/A			
C. AIRCRAFT OPERATION AND MAINTENANCE RECORDS		CHECK IF RECORDS IN COMPLIANCE WITH 14 CFR Section 91.417		TOTAL AIRFRAME HOURS		EXPERIMENTAL ONLY (Enter hours flown since last certificate issued or renewed)						
				293.0		3 293.0						
D. CERTIFICATION - I hereby certify that I am the registered owner (or his agent) of the aircraft described above, that the aircraft is registered with the Federal Aviation Administration in accordance with Title 49 of the United States Code 44101 et seq. and applicable Federal Aviation Regulations, and that the aircraft has been inspected and is airworthy and eligible for the airworthiness certificate requested.												
DATE OF APPLICATION		NAME AND TITLE (Print or type)			SIGNATURE							
October 20, 2009		Alan Ram (Vice President)										
A. THE AIRCRAFT DESCRIBED ABOVE HAS BEEN INSPECTED AND FOUND AIRWORTHY BY: (Complete the section only if 14 CFR part 21.183(d) applies.)												
2:	14 CFR part 121 CERTIFICATE HOLDER (Give Certificate No.)		3:	CERTIFICATED MECHANIC (Give Certificate No.)		6:	CERTIFICATED REPAIR STATION (Give Certificate No.)					
5:	AIRCRAFT MANUFACTURER (Give name or firm)											
DATE		TITLE			SIGNATURE							
V. FAA REPRESENTATIVE CERTIFICATION	(Check ALL applicable block items A and B)											
	A. I find that the aircraft described in Section I or VII meets requirements for				THE CERTIFICATE REQUESTED							
	B. Inspection for a special permit under Section VII was conducted by:				AMENDMENT OR MODIFICATION OF CURRENT AIRWORTHINESS CERTIFICATE							
	DATE		DISTRICT OFFICE		DESIGNEE'S SIGNATURE AND NO.		FAA INSPECTOR'S SIGNATURE					
10-9-2009		Atlanta MIDO		J. Hamilton DARE501107CE								

1900

1900

VL PRODUCTION FLIGHT TESTING	A. MANUFACTURER				
	NAME		ADDRESS		
	B. PRODUCTION BASIS (Check applicable item)				
	PRODUCTION CERTIFICATE (Give production certificate number) _____				
	TYPE CERTIFICATE ONLY				
APPROVED PRODUCTION INSPECTION SYSTEM					
C. GIVE QUANTITY OF CERTIFICATES REQUIRED FOR OPERATING NEEDS					
DATE OF APPLICATION		NAME AND TITLE (Print or Type)	SIGNATURE		
VL SPECIAL FLIGHT PERMIT PURPOSES OTHER THAN PRODUCTION FLIGHT TEST	A. DESCRIPTION OF AIRCRAFT				
	REGISTERED OWNER		ADDRESS		
	BUILDER (Make)		MODEL		
	SERIAL NUMBER		REGISTRATION MARK		
	B. DESCRIPTION OF FLIGHT				
	FROM		TO		
	VIA		DEPARTURE DATE	DURATION	
	C. CREW REQUIRED TO OPERATE THE AIRCRAFT AND ITS EQUIPMENT				
		PILOT	CO-PILOT	FLIGHT ENGINEER	OTHER (Specify)
	D. THE AIRCRAFT DOES NOT MEET THE APPLICABLE AIRWORTHINESS REQUIREMENTS AS FOLLOWS:				
	E. THE FOLLOWING RESTRICTIONS ARE CONSIDERED NECESSARY FOR SAFE OPERATION: (Use attachment if necessary)				
	F. CERTIFICATION - I hereby certify that I am the registered owner (or his agent) of the aircraft described above; that the aircraft is registered with the Federal Aviation Administration in accordance with Title 49 of the United States Code 44101 et seq., and applicable Federal Aviation Regulations; and that the aircraft has been inspected and is safe for the flight described.				
	DATE		NAME AND TITLE (Print or Type)	SIGNATURE	
VL AIRWORTHINESS DOCUMENTATION (FAA/DESIGNEE use only)	A. Operating Limitations and Markings in Compliance with 14 CFR Section 91.9, as applicable.		G. Statement of Conformity, FAA Form 8130-9 (Attach when required)		
	✓ B. Current Operating Limitations Attached		H. Foreign Airworthiness Certification for Import Aircraft (Attach when required)		
	C. Data, Drawings, Photographs, etc. (Attach when required)		I. Previous Airworthiness Certificate Issued in Accordance with 14 CFR Section 21.191 (a) CAR _____ (Original Attached)		
	✓ D. Current Weight and Balance information Available in Aircraft		✓ J. Current Airworthiness Certificate Issued in Accordance with 14 CFR Section 21.191 (a) (Copy Attached)		
	E. Major Repair and Alteration, FAA Form 337 (Attach when required)		K. Light-Sport Aircraft Statement of Compliance, FAA Form 8130-15 (Attach when required)		
	✓ F. This inspection Recorded in Aircraft Records				

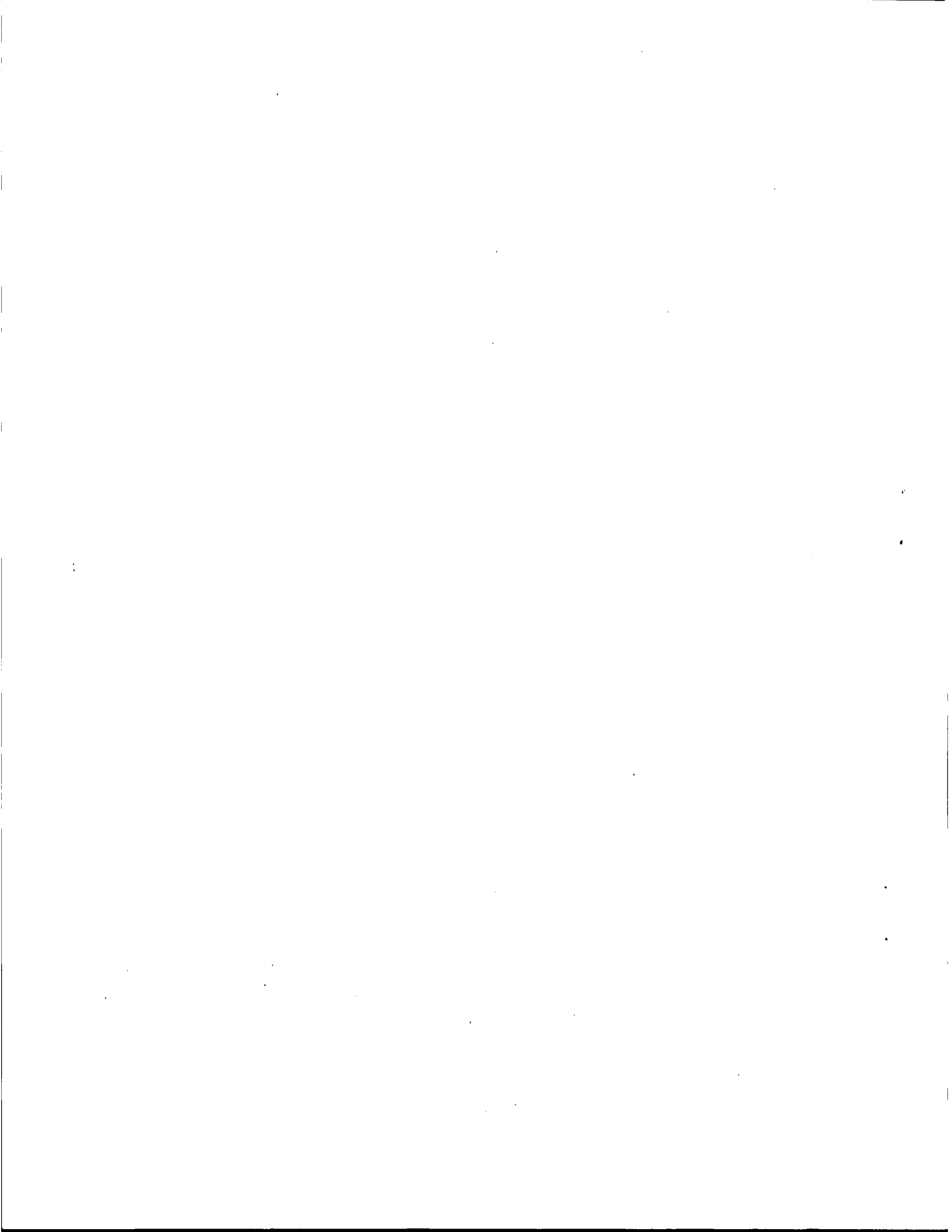

UNITED STATES OF AMERICA
DEPARTMENT OF TRANSPORTATION - FEDERAL AVIATION ADMINISTRATION
SPECIAL AIRWORTHINESS CERTIFICATE

A	CATEGORY/DESIGNATION	EXPERIMENTAL	
	PURPOSE	RESEARCH AND DEVELOPMENT	
B	MANU-FACTURER	NAME	N/A
		ADDRESS	N/A
C	FLIGHT	FROM	N/A
		TO	N/A
D	N-6542B		SERIAL NO. 400-01
	BUILDER BLACKWATER AIRSHIPS LLC		MODEL POLAR 400
E	DATE OF ISSUANCE NOV 9, 2009		EXPIRY MAY 8, 2010
	OPERATING LIMITATIONS DATED		ARE A PART OF THIS CERTIFICATE
	SIGNATURE OF FAA REPRESENTATIVE		DESIGNATION OR OFFICE NO.
	J HANKINSON <i>J. Hankinson</i>		DARF501107CE

Any alteration, reproduction or misuse of this certificate may be punishable by a fine not exceeding \$1,000 or imprisonment not exceeding 3 years, or both. THIS CERTIFICATE MUST BE DISPLAYED IN THE AIRCRAFT IN ACCORDANCE WITH APPLICABLE FEDERAL AVIATION REGULATIONS.

A	This airworthiness certificate is issued under the authority of the Federal Aviation Act of 1958 and the Federal Aviation Regulations (FAR).
B	This airworthiness certificate authorizes the manufacturer named on the reverse side to conduct production flight tests, and only production flight tests, of aircraft registered in his name. No person may conduct production flight tests under this certificate: (1) Carrying persons or property for compensation or hire; and/or (2) Carrying persons not essential to the purpose of the flight.
C	This airworthiness certificate authorizes the flight specified on the reverse side for the purpose shown in Block A.
D	This airworthiness certificate certifies that, as of the date of issuance, the aircraft to which issued has been inspected and found to meet the requirements of the applicable FAR. The aircraft does not meet the requirements of the applicable comprehensive and detailed airworthiness code as provided by Annex 8 to the Convention On International Civil Aviation. No person may operate the aircraft described on the reverse side: (1) except in accordance with the applicable FAR and in accordance with conditions and limitations which may be prescribed by the Administrator as part of this certificate; (2) over any foreign country without the special permission of that country.
E	Unless sooner surrendered, suspended, or revoked, this airworthiness certificate is effective for the duration and under the conditions prescribed in FAR Part 21, Section 21.181 or 21.217.

UNITED STATES OF AMERICA
DEPARTMENT OF TRANSPORTATION - FEDERAL AVIATION ADMINISTRATION
SPECIAL AIRWORTHINESS CERTIFICATE

A	CATEGORY/DESIGNATION EXPERIMENTAL	
	PURPOSE RESEARCH AND DEVELOPMENT	
B	MANU-FACTURER	NAME N/A ADDRESS N/A
C	FLIGHT	FROM N/A TO N/A
D	N-6542B BUILDER BLACKWATER AIRSHIPS LLC	SERIAL NO. 400-001 MODEL POLAR 400
	DATE OF ISSUANCE JULY 10, 2009	EXPIRY NOV 9, 2009
E	OPERATING LIMITATIONS DATED JUL 10, 2009 ARE A PART OF THIS CERTIFICATE	
	SIGNATURE OF FAA REPRESENTATIVE <i>J. Hankinson</i> J. HANKINSON	DESIGNATION OR OFFICE NO. DARF501107CE

Any alteration, reproduction or misuse of this certificate may be punishable by a fine not exceeding \$1,000 or imprisonment not exceeding 3 years, or both. THIS CERTIFICATE MUST BE DISPLAYED IN THE AIRCRAFT IN ACCORDANCE WITH APPLICABLE FEDERAL AVIATION REGULATIONS.

A	This airworthiness certificate is issued under the authority of the Federal Aviation Act of 1958 and the Federal Aviation Regulations (FAR).
B	This airworthiness certificate authorizes the manufacturer named on the reverse side to conduct production flight tests, and only production flight tests, of aircraft registered in his name. No person may conduct production flight tests under this certificate: (1) Carrying persons or property for compensation or hire; and/or (2) Carrying persons not essential to the purpose of the flight.
C	This airworthiness certificate authorizes the flight specified on the reverse side for the purpose shown in Block A.
D	This airworthiness certificate certifies that, as of the date of issuance, the aircraft to which issued has been inspected and found to meet the requirements of the applicable FAR. The aircraft does not meet the requirements of the applicable comprehensive and detailed airworthiness code as provided by Annex 8 to the Convention On International Civil Aviation. No person may operate the aircraft described on the reverse side: (1) except in accordance with the applicable FAR and in accordance with conditions and limitations which may be prescribed by the Administrator as part of this certificate; (2) over any foreign country without the special permission of that country.
E	Unless sooner surrendered, suspended, or revoked, this airworthiness certificate is effective for the duration and under the conditions prescribed in FAR Part 21, Section 21.181 or 21.217.



U.S. Department
of Transportation
**Federal Aviation
Administration**

**SPECIAL
EXPERIMENTAL
RESEARCH and DEVELOPMENT
OPERATING LIMITATIONS**

MAKE: Blackwater Airships, LLC

MODEL: Polar 400

SERIAL NUMBER: 400-001

REG. NUMBER: N6542B

Date Issued: November 9, 2009

Expiration Date: May 8, 2010

- 1) No person may operate this aircraft unless Form 8130-7 is displayed at the cockpit entrance and visible to flight crew members.
- 2) No person may operate this aircraft for other than the purpose of Research and Development, to accomplish the flight operation outlined in the program letter dated October 20, 2009, which describes compliance with §21.193(d), and has been made available to the pilot in command of the aircraft. In addition, this aircraft must be operated in accordance with applicable air traffic and general operating rules of part 91, and all additional limitations herein prescribed under provisions of §91.319(e).
- 3) All flights of this aircraft must be conducted over open water or sparsely populated areas having light air traffic, within the geographic area described as follows: Within 150 nautical mile radius of the former Weeksville, NC Naval Air Station (EKV) 36°13'59.19"N, 76°08'0.01"W.
- 4) This aircraft must not be operated unless it is inspected and maintained in accordance with the manufacturers recommendations. The owner/operator must select, establish, identify, and use an inspection program as set forth in §91.409(e), (f), (g) and (h). This inspection program must be recorded in the aircraft maintenance records.
- 5) The pilot in command of this aircraft must hold an appropriate category/class rating. If required for the type of aircraft to be flown, the pilot in command also must hold either an appropriate type rating or a letter of authorization issued by an FAA Flight Standards Operations Inspector.
- 6) This aircraft is to be operated under VFR, day and/or night.
- 7) No person may operate this aircraft for carrying persons or property for compensation or hire.
- 8) No person may be carried in this aircraft during flight unless that person is essential to the purpose of the flight.
- 9) The pilot in command of this aircraft must advise each passenger of the experimental nature of this aircraft, and explain that it does not meet the certification requirements of a standard certificated aircraft.



- 10) This aircraft must contain the placards, markings, etc. required by §91.9(c).
- 11) This aircraft is prohibited from aerobatic flight, that is, an intentional maneuver involving an abrupt change in the aircraft's attitude, an abnormal attitude, or abnormal acceleration not necessary for normal flight.
- 12) No person may operate this aircraft unless within the preceding 12 calendar months it has had a condition inspection performed in accordance with appendix D of part 43, or other FAA approved program, and was found to be in a condition for safe operation. This inspection will be recorded in the aircraft maintenance records.
- 13) Only FAA certificated mechanics with appropriate ratings as authorized by §43.3 may perform inspections required by these operating limitations.
- 14) Inspections must be recorded in the aircraft maintenance records showing the following, or a similar worded statement: " I certify that this aircraft has been inspected on [insert date] in accordance with the scope and detail of appendix D to part 43, or other FAA approved program, and was found to be in a condition of safe operation." The entry will include the aircraft's total time-in-service, and the name, signature, certificate held by the person performing the inspection.
- 15) This aircraft must display the word "EXPERIMENTAL" in accordance with §45.23(b).
- 16) The pilot in command of this aircraft must notify air traffic control of the experimental nature of this aircraft when operating into or out of airports with operating control towers. The pilot in command must plan routing that will avoid densely populated areas and congested airways when operating VFR.
- 17) Aircraft instruments and equipment installed and used under §91.205 must be inspected and maintained in accordance with the requirements of parts 43 and 91. Any maintenance or inspection of this equipment must be recorded in the aircraft maintenance records.
- 18) Application must be made to the Atlanta MIDO for any revision to these operating limitations.
- 19) Section §47.45 requires that the FAA Aircraft Registry must be notified within 30 days of any change in the aircraft registrant's address. Such notification is to be made by submitting Form 8050-1 to AFS-750 in Oklahoma City, Oklahoma.

November 9, 2009
Date

J. Hankinson
FAA Representative

John Hankinson

DARF501107CE
Designation

These operating Limitations have been explained, are understood and accepted

November 9, 2009
Date

JM Fadd
Pilot in Command

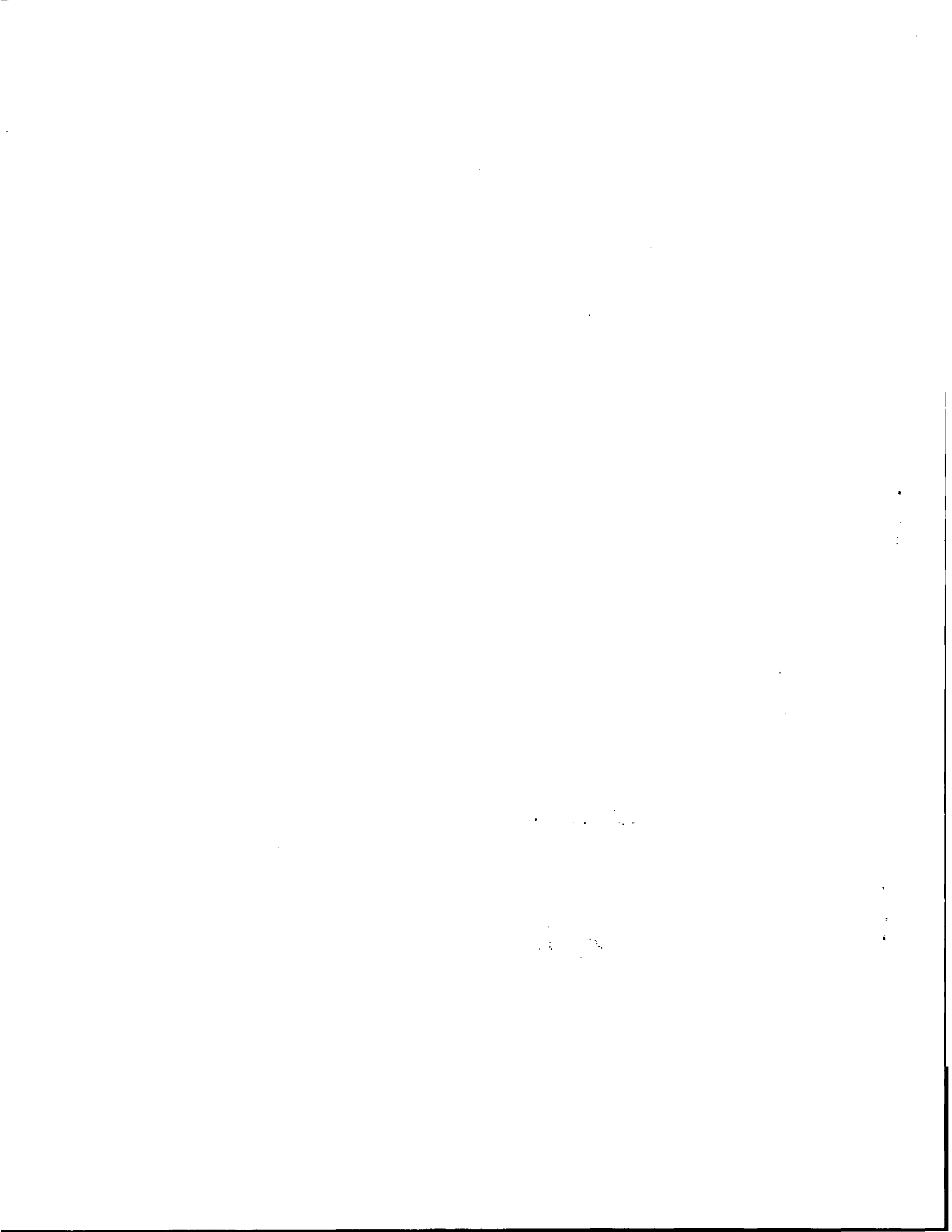

FNAME

REVDATE

USER

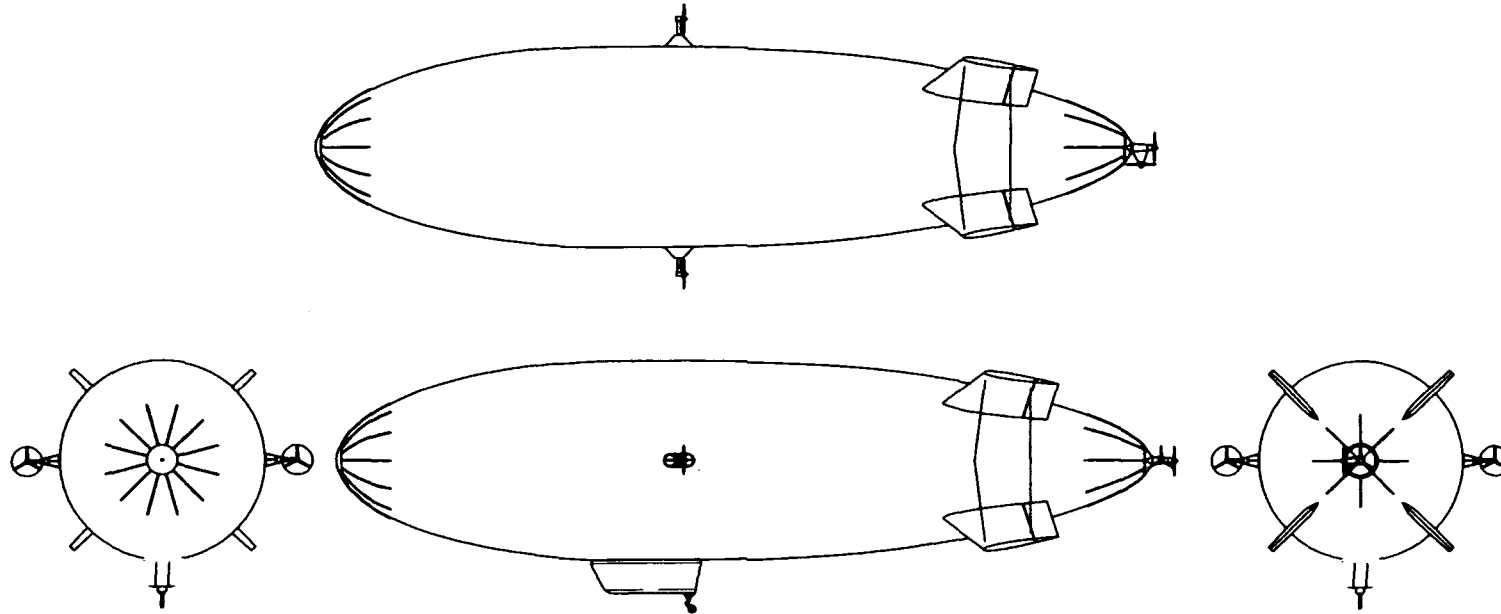

REVISIONS				
ZONE	REV	DESCRIPTION	DATE	APPROVED
	A	INITIAL RELEASE	07-08-07	-



ITEM	QTY.	PART NUMBER	DESCRIPTION	REMARKS
CAD DWG.		DO NOT SCALE DRAWING		
UNLESS OTHERWISE SPECIFIED		BLACKWATER AIRSHIPS LLC		
ALL DIMENSIONS ARE IN INCHES		ELIZABETH CITY, NORTH CAROLINA 27909		
TOLERANCES		DESCRIPTION		
ANGLES -0° 30'		POLAR 400 GA		
FRACTION 21/64		SIZE PART NO.		
DECIMALS		D 400-00-008		
X .25		REV. A		
XX .005		SHT. 1/A		
XXX .0005		SCALE: N.T.S.		
DIMENSIONS AND TOLERANCES APPLY AFTER PLATING		APPROVED NAME		
REMOVE ALL BURRS AND SHARP EDGES		DATE D H Y		

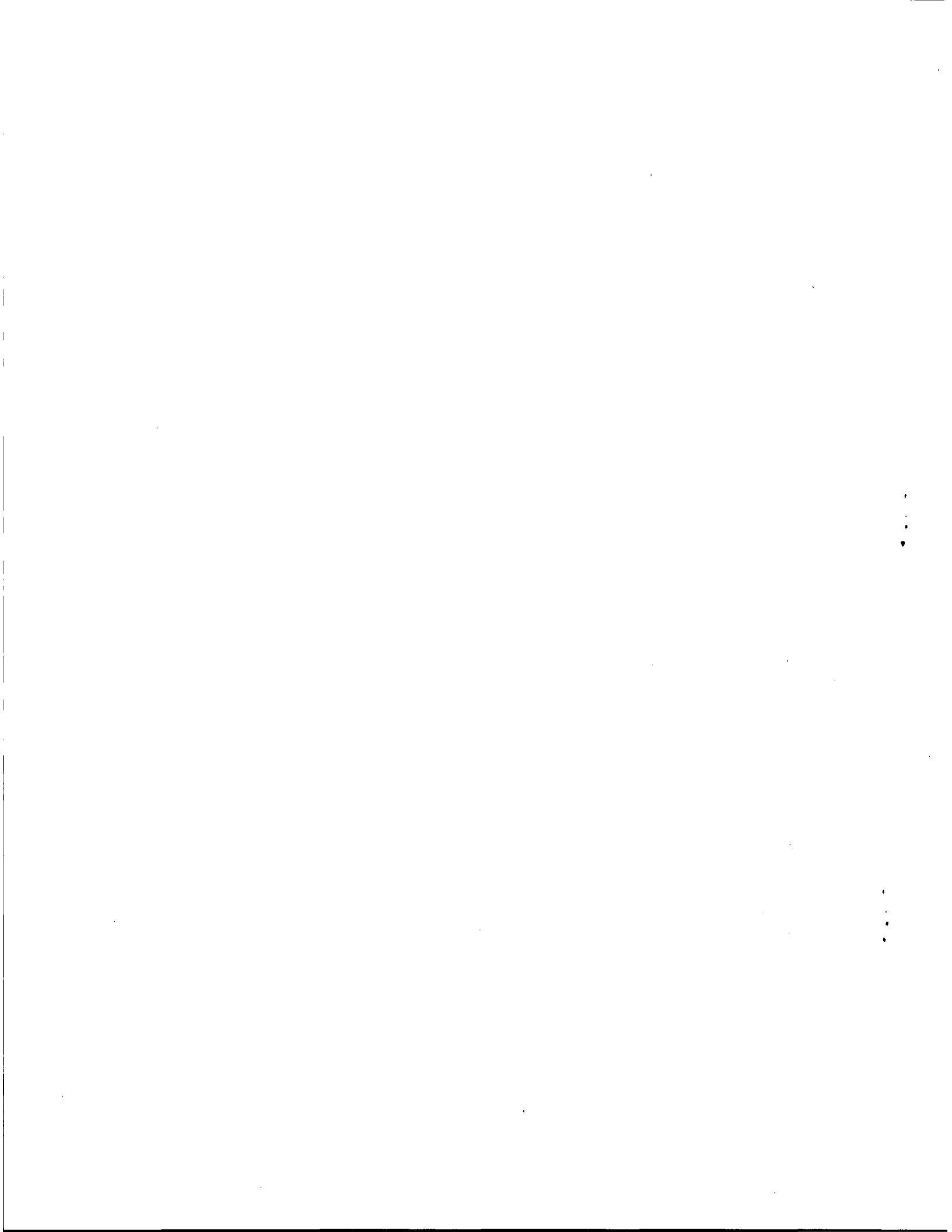

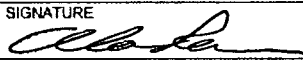

FAA FORM 8130-6, APPLICATION FOR U.S. AIRWORTHINESS CERTIFICATE

Form Approved O.M.B. No. 2120-0018 Exp. date: 12/31/2010

 <p>U.S. Department of Transportation Federal Aviation Administration</p>		<p>APPLICATION FOR U.S. AIRWORTHINESS CERTIFICATE</p>		<p>INSTRUCTIONS - Print or type. Do not write in shaded areas; these are for FAA use only. Submit original only to an authorized FAA Representative. If additional space is required, use attachment. For special flight permits complete Sections II, VI and VII as applicable.</p>												
I. AIRCRAFT DESIGNATION	1. REGISTRATION MARK	2. AIRCRAFT BUILDER'S NAME (Make)	3. AIRCRAFT MODEL DESIGNATION	4. YR. MFR	FAA CODING											
	N6542B	Blackwater Airships, LLC	Polar 400	2007												
	5. AIRCRAFT SERIAL NO.	6. ENGINE BUILDER'S NAME (Make)	7. ENGINE MODEL DESIGNATION													
	400-001	Thielert Aircraft Engines	Centurian 4.0													
8. NUMBER OF ENGINES	9. PROPELLER BUILDER'S NAME (Make)	10. PROPELLER MODEL DESIGNATION		11. AIRCRAFT IS (Check if applicable)												
1 (One)	MT-Propeller GmbH	MTV-6-A-CR(H)/CRRD175-05		IMPORT												
APPLICATION IS HEREBY MADE FOR: (Check applicable items)																
<table border="1"> <tr> <td>A</td> <td>1</td> <td>STANDARD AIRWORTHINESS CERTIFICATE (Indicate Category)</td> <td>NORMAL</td> <td>UTILITY</td> <td>ACROBATIC</td> <td>TRANSPORT</td> <td>COMBUSTER</td> <td>BALLOON</td> <td>OTHER</td> </tr> </table>							A	1	STANDARD AIRWORTHINESS CERTIFICATE (Indicate Category)	NORMAL	UTILITY	ACROBATIC	TRANSPORT	COMBUSTER	BALLOON	OTHER
A	1	STANDARD AIRWORTHINESS CERTIFICATE (Indicate Category)	NORMAL	UTILITY	ACROBATIC	TRANSPORT	COMBUSTER	BALLOON	OTHER							
B SPECIAL AIRWORTHINESS CERTIFICATE (Check appropriate items)																
7. PRIMARY																
9. LIGHT-SPORT (Indicate Class)																
2. LIMITED																
5. PROVISIONAL (Indicate Class)																
3. RESTRICTED (Indicate operation(s) to be conducted)																
4. EXPERIMENTAL (Indicate operation(s) to be conducted)																
8. SPECIAL FLIGHT PERMIT (Indicate operation(s) to be conducted, then complete Section VI or VII as applicable on reverse side)																
C 6. MULTIPLE AIRWORTHINESS CERTIFICATE (check ABOVE "Restricted Operation" and "Standard" or "Limited" as applicable)																
III. OWNER'S CERTIFICATION																
A. REGISTERED OWNER (As shown on certificate of aircraft registration) IF DEALER, CHECK HERE																
NAME: Blackwater Airships, LLC ADDRESS: PO Box 1029, Moyock NC 27958-1029																
B. AIRCRAFT CERTIFICATION BASIS (Check applicable blocks and complete items as indicated)																
AIRCRAFT SPECIFICATION OR TYPE CERTIFICATE DATA SHEET (Give No. and Revision No.): N/A AIRWORTHINESS DIRECTIVES (Check if all applicable AD's are compiled with and give the number of the last AD SUPPLEMENT available in the biweekly series as of the date of application): N/A																
AIRCRAFT LISTING (Give page number(s)): N/A SUPPLEMENTAL TYPE CERTIFICATE (List number of each STC incorporated): N/A																
C. AIRCRAFT OPERATION AND MAINTENANCE RECORDS																
CHECK IF RECORDS IN COMPLIANCE WITH 14 CFR Section 91.417: TOTAL AIRFRAME HOURS: 155.0 EXPERIMENTAL ONLY (Enter hours flown since last certificate issued or renewed): 155.0																
D. CERTIFICATION - I hereby certify that I am the registered owner (or his agent) of the aircraft described above, that the aircraft is registered with the Federal Aviation Administration in accordance with Title 49 of the United States Code 44101 et seq. and applicable Federal Aviation Regulations, and that the aircraft has been inspected and is airworthy and eligible for the airworthiness certificate requested.																
DATE OF APPLICATION: June 29, 2009 NAME AND TITLE (Print or type): Alan Ram (Vice President) SIGNATURE: 																
IV. INSPECTION AGENCY VERIFICATION																
A. THE AIRCRAFT DESCRIBED ABOVE HAS BEEN INSPECTED AND FOUND AIRWORTHY BY: (Complete the section only if 14 CFR part 21.163(d) applies)																
2. 14 CFR part 121 CERTIFICATE HOLDER (Give Certificate No.): 3. CERTIFICATED MECHANIC (Give Certificate No.): 6. CERTIFICATED REPAIR STATION (Give Certificate No.):																
5. AIRCRAFT MANUFACTURER (Give name or firm):																
DATE: TITLE: SIGNATURE:																
V. FAA REPRESENTATIVE CERTIFICATION																
(Check ALL applicable block items A and B)																
A. I find that the aircraft described in Section I or VII meets requirements for THE CERTIFICATE REQUESTED																
B. Inspection for a special permit under Section VII was conducted by: FAA INSPECTOR: CERTIFICATE HOLDER UNDER: 14 CFR part 65: 14 CFR part 121 OR 135: 14 CFR part 145:																
DATE: DISTRICT OFFICE: DESIGNEE'S SIGNATURE AND NO.: FAA INSPECTOR'S SIGNATURE:																
July 10, 2009 Atlanta MIDO 4.  DAAFS01107CE 1.																

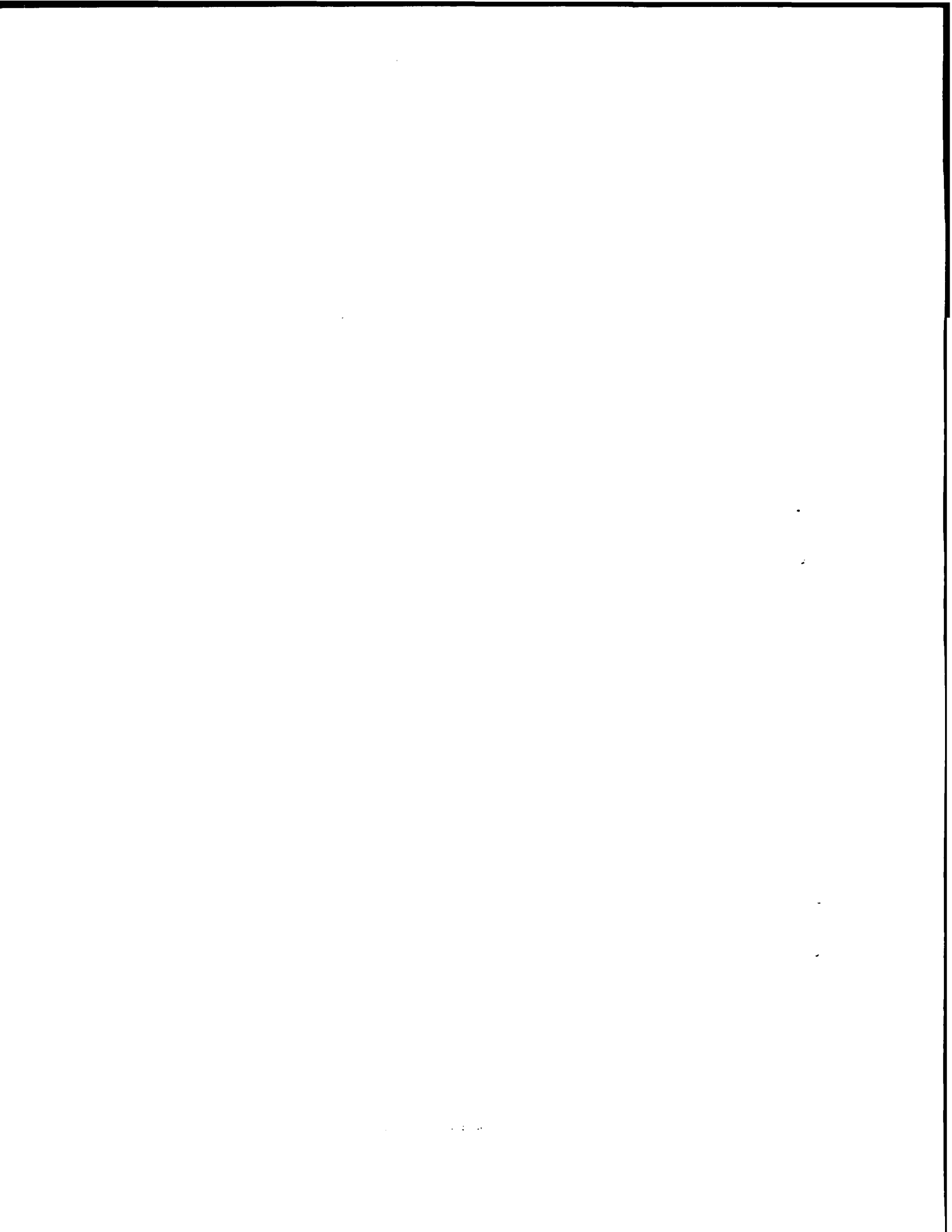

VI. PRODUCTION FLIGHT TESTING	A. MANUFACTURER							
	NAME	ADDRESS						
	B. PRODUCTION BASIS <i>(Check applicable item)</i>							
	<input type="checkbox"/>	PRODUCTION CERTIFICATE <i>(Give production certificate number)</i> _____						
	<input type="checkbox"/>	TYPE CERTIFICATE ONLY						
<input type="checkbox"/>	APPROVED PRODUCTION INSPECTION SYSTEM							
C. GIVE QUANTITY OF CERTIFICATES REQUIRED FOR OPERATING NEEDS								
DATE OF APPLICATION	NAME AND TITLE <i>(Print or Type)</i>	SIGNATURE						
VII. SPECIAL FLIGHT PERMIT PURPOSES OTHER THAN PRODUCTION FLIGHT TEST	A. DESCRIPTION OF AIRCRAFT							
	REGISTERED OWNER	ADDRESS						
	BUILDER <i>(Make)</i>	MODEL						
	SERIAL NUMBER	REGISTRATION MARK						
	B. DESCRIPTION OF FLIGHT							
	CUSTOMER DEMONSTRATION FLIGHTS <input type="checkbox"/> <i>(Check if applicable)</i>							
	FROM	TO						
	VIA	DEPARTURE DATE	DURATION					
	C. CREW REQUIRED TO OPERATE THE AIRCRAFT AND ITS EQUIPMENT							
	<input type="checkbox"/>	PILOT	<input type="checkbox"/>	CO-PILOT	<input type="checkbox"/>	FLIGHT ENGINEER	<input type="checkbox"/>	OTHER <i>(Specify)</i>
	D. THE AIRCRAFT DOES NOT MEET THE APPLICABLE AIRWORTHINESS REQUIREMENTS AS FOLLOWS:							
E. THE FOLLOWING RESTRICTIONS ARE CONSIDERED NECESSARY FOR SAFE OPERATION: <i>(Use attachment if necessary)</i>								
F. CERTIFICATION – I hereby certify that I am the registered owner (or his agent) of the aircraft described above; that the aircraft is registered with the Federal Aviation Administration in accordance with Title 49 of the United States Code 44101 <u>et seq.</u> , and applicable Federal Aviation Regulations; and that the aircraft has been inspected and is safe for the flight described.								
DATE	NAME AND TITLE <i>(Print or Type)</i>					SIGNATURE		
VIII. AIRWORTHINESS DOCUMENTATION <i>(FAA/DESIGNEE use only)</i>	<input type="checkbox"/> A. Operating Limitations and Markings in Compliance with 14 CFR Section 91.9, as applicable.				<input type="checkbox"/> G. Statement of Conformity, FAA Form 8130-9 <i>(Attach when required)</i>			
	<input checked="" type="checkbox"/> B. Current Operating Limitations Attached				<input type="checkbox"/> H. Foreign Airworthiness Certification for Import Aircraft <i>(Attach when required)</i>			
	<input type="checkbox"/> C. Data, Drawings, Photographs, etc. <i>(Attach when required)</i>				<input checked="" type="checkbox"/> I. Previous Airworthiness Certificate Issued in Accordance with 14 CFR Section <u>21.191 (a)</u> CAR _____ <i>(Original Attached)</i>			
	<input checked="" type="checkbox"/> D. Current Weight and Balance Information Available in Aircraft				<input checked="" type="checkbox"/> J. Current Airworthiness Certificate Issued in Accordance with 14 CFR Section <u>21.191 (a)</u> _____ <i>(Copy Attached)</i>			
	<input type="checkbox"/> E. Major Repair and Alteration, FAA Form 337 <i>(Attach when required)</i>				<input checked="" type="checkbox"/> K. Light-Sport Aircraft Statement of Compliance, FAA Form 8130-15 <i>(Attach when required)</i>			
	<input checked="" type="checkbox"/> F. This inspection Recorded in Aircraft Records							

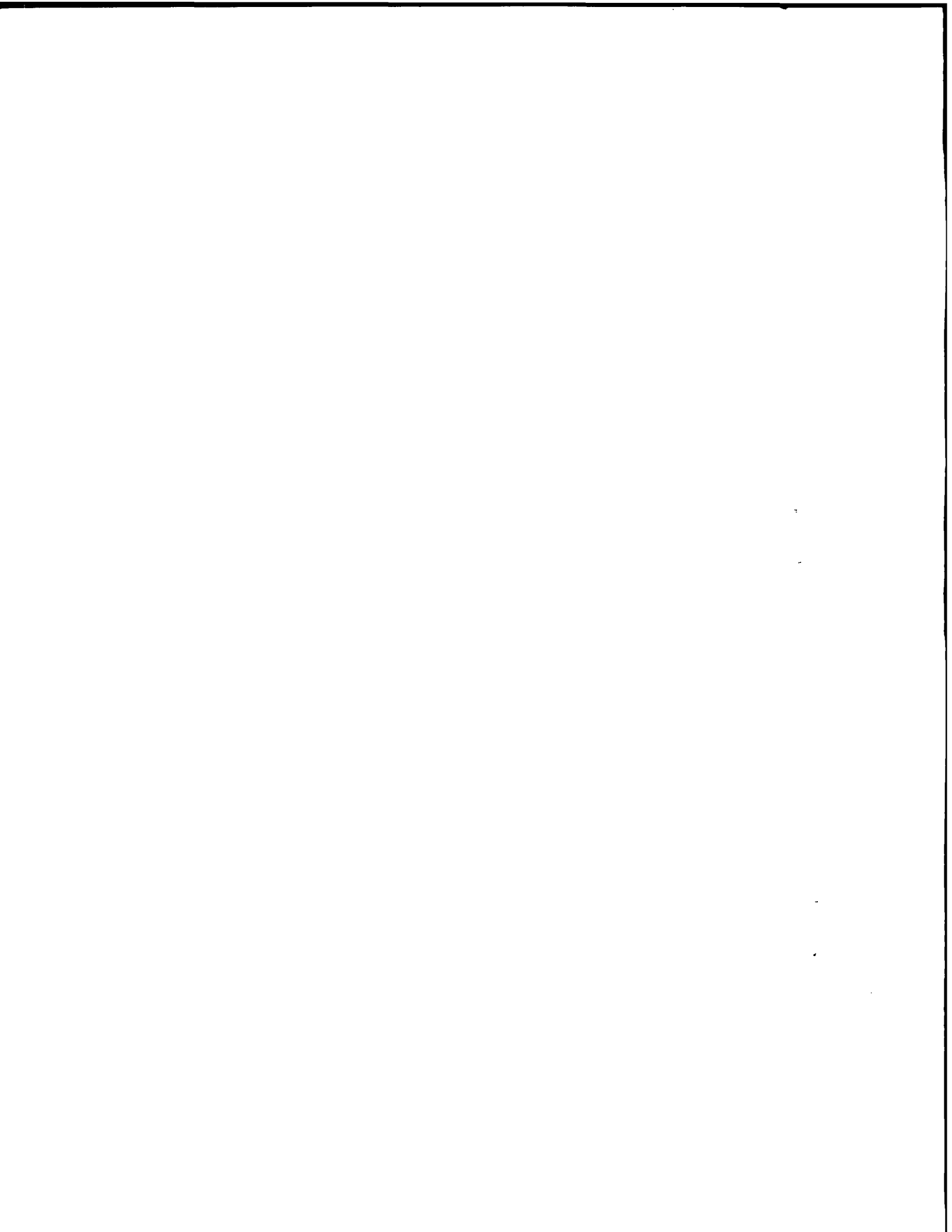

UNITED STATES OF AMERICA
DEPARTMENT OF TRANSPORTATION - FEDERAL AVIATION ADMINISTRATION
SPECIAL AIRWORTHINESS CERTIFICATE

A	CATEGORY/DESIGNATION	EXPERIMENTAL	
	PURPOSE	RESEARCH AND DEVELOPMENT	
B	MANU-FACTURER	NAME	N/A
		ADDRESS	N/A
C	FLIGHT	FROM	N/A
		TO	N/A
D	N-	6542B	SERIAL NO. 400-001
	BUILDER	BLACKWATER AIRSHIPS LLC	MODEL POLAR 400
E	DATE OF ISSUANCE JULY 10, 2009		EXPIRY NOV 9, 2009
	OPERATING LIMITATIONS DATED JUL 10, 2009 ARE A PART OF THIS CERTIFICATE		
SIGNATURE OF FAA REPRESENTATIVE		DESIGNATION OR OFFICE NO.	
 J. HANKINSON		DARF501107CE	

Any alteration, reproduction or misuse of this certificate may be punishable by a fine not exceeding \$1,000 or imprisonment not exceeding 3 years, or both. THIS CERTIFICATE MUST BE DISPLAYED IN THE AIRCRAFT IN ACCORDANCE WITH APPLICABLE FEDERAL AVIATION REGULATIONS.

A	This airworthiness certificate is issued under the authority of the Federal Aviation Act of 1958 and the Federal Aviation Regulations (FAR).
B	This airworthiness certificate authorizes the manufacturer named on the reverse side to conduct production flight tests, and only production flight tests, of aircraft registered in his name. No person may conduct production flight tests under this certificate: (1) Carrying persons or property for compensation or hire; and/or (2) Carrying persons not essential to the purpose of the flight.
C	This airworthiness certificate authorizes the flight specified on the reverse side for the purpose shown in Block A.
D	This airworthiness certificate certifies that, as of the date of issuance, the aircraft to which issued has been inspected and found to meet the requirements of the applicable FAR. The aircraft does not meet the requirements of the applicable comprehensive and detailed airworthiness code as provided by Annex 8 to the Convention On International Civil Aviation. No person may operate the aircraft described on the reverse side: (1) except in accordance with the applicable FAR and in accordance with conditions and limitations which may be prescribed by the Administrator as part of this certificate; (2) over any foreign country without the special permission of that country.
E	Unless sooner surrendered, suspended, or revoked, this airworthiness certificate is effective for the duration and under the conditions prescribed in FAR Part 21, Section 21.181 or 21.217.

UNITED STATES OF AMERICA
 DEPARTMENT OF TRANSPORTATION - FEDERAL AVIATION ADMINISTRATION
SPECIAL AIRWORTHINESS CERTIFICATE

A	CATEGORY/DESIGNATION	EXPERIMENTAL	
	PURPOSE	RESEARCH AND DEVELOPMENT	
B	MANUFACTURER	NAME	N/A
		ADDRESS	N/A
C	FLIGHT	FROM	N/A
		TO	N/A
D	N-	6542B	SERIAL NO. 400-003
	BUILDER	BLACKHATER AIRSHIPS LLC	MODEL POLAR 400
E	DATE OF ISSUANCE	SEPT 5, 2008	EXPIRY SEPT 4, 2009
	OPERATING LIMITATIONS DATED SEPT 5, 2008 ARE A PART OF THIS CERTIFICATE		
	SIGNATURE OF FAA REPRESENTATIVE		DESIGNATION OR OFFICE NO.
		J. HANKINSON <i>J. Hankinson</i>	DARF501107CE

Any alteration, reproduction or misuse of this certificate may be punishable by a fine not exceeding \$1,000 or imprisonment not exceeding 3 years, or both. THIS CERTIFICATE MUST BE DISPLAYED IN THE AIRCRAFT IN ACCORDANCE WITH APPLICABLE FEDERAL AVIATION REGULATIONS.

A	This airworthiness certificate is issued under the authority of the Federal Aviation Act of 1958 and the Federal Aviation Regulations (FAR).
B	This airworthiness certificate authorizes the manufacturer named on the reverse side to conduct production flight tests, and only production flight tests, of aircraft registered in his name. No person may conduct production flight tests under this certificate: (1) Carrying persons or property for compensation or hire; and/or (2) Carrying persons not essential to the purpose of the flight.
C	This airworthiness certificate authorizes the flight specified on the reverse side for the purpose shown in Block A.
D	This airworthiness certificate certifies that, as of the date of issuance, the aircraft to which issued has been inspected and found to meet the requirements of the applicable FAR. The aircraft does not meet the requirements of the applicable comprehensive and detailed airworthiness code as provided by Annex 8 to the Convention On International Civil Aviation. No person may operate the aircraft described on the reverse side: (1) except in accordance with the applicable FAR and in accordance with conditions and limitations which may be prescribed by the Administrator as part of this certificate; (2) over any foreign country without the special permission of that country.
E	Unless sooner surrendered, suspended, or revoked, this airworthiness certificate is effective for the duration and under the conditions prescribed in FAR Part 21, Section 21.181 or 21.217.



U.S. Department
of Transportation
**Federal Aviation
Administration**

**SPECIAL
EXPERIMENTAL
RESEARCH and DEVELOPMENT
OPERATING LIMITATIONS**

MAKE: Blackwater Airships, LLC

MODEL: Polar 400

SERIAL NUMBER: 400-001

REG. NUMBER: N6542B

Date Issued: July 10, 2009

Expiration Date: November 9, 2009

- 1) No person may operate this aircraft unless Form 8130-7 is displayed at the cockpit entrance and visible to flight crew members
- 2) No person may operate this aircraft for other than the purpose of Research and Development, to accomplish the flight operation outlined in the program letter dated June 29, 2009, which describes compliance with §21.193(d), and has been made available to the pilot in command of the aircraft. In addition, this aircraft must be operated in accordance with applicable air traffic and general operating rules of part 91, and all additional limitations herein prescribed under provisions of §91.319(e).
- 3) All flights of this aircraft may only be conducted over open water or sparsely populated areas having light air traffic, within the geographical areas described as follows: Within 150 NM radius of the former Weeksville, NC Naval Air Station (EKV) (N 36°13'59.19", W 76°08'0.01") and 15 NM radius of Lakehurst NJ Naval Air Engineering Station (former Naval Air Station (NEL) (N 40° 01' 57", W 74° 20' 29"). The aircraft shall be able to transit between these two geographical areas utilizing the most direct route, but shall have the necessary operational flexibility to circumnavigate weather, populated areas, hazards, etc.
- 4) This aircraft must not be operated unless it is inspected and maintained in accordance with the manufacturers recommendations. The owner/operator must select, establish, identify, and use an inspection program. This inspection program must be recorded in the aircraft maintenance records.
- 5) The pilot in command of this aircraft must hold an appropriate category/class rating. If required for the type of aircraft to be flown, the pilot in command also must hold either an appropriate type rating or a letter of authorization issued by an FAA Flight Standards Operations Inspector.
- 6) This aircraft is to be operated under VFR, day and/or night.
- 7) No person may operate this aircraft for carrying persons or property for compensation or hire.
- 8) No person may be carried in this aircraft during flight unless that person is essential to the purpose of the flight.
- 9) The pilot in command of this aircraft must advise each passenger of the experimental nature of this aircraft, and explain that it does not meet the certification requirements of a standard certificated aircraft.
- 10) This aircraft must contain the placards, markings, etc. required by §91.9(c).

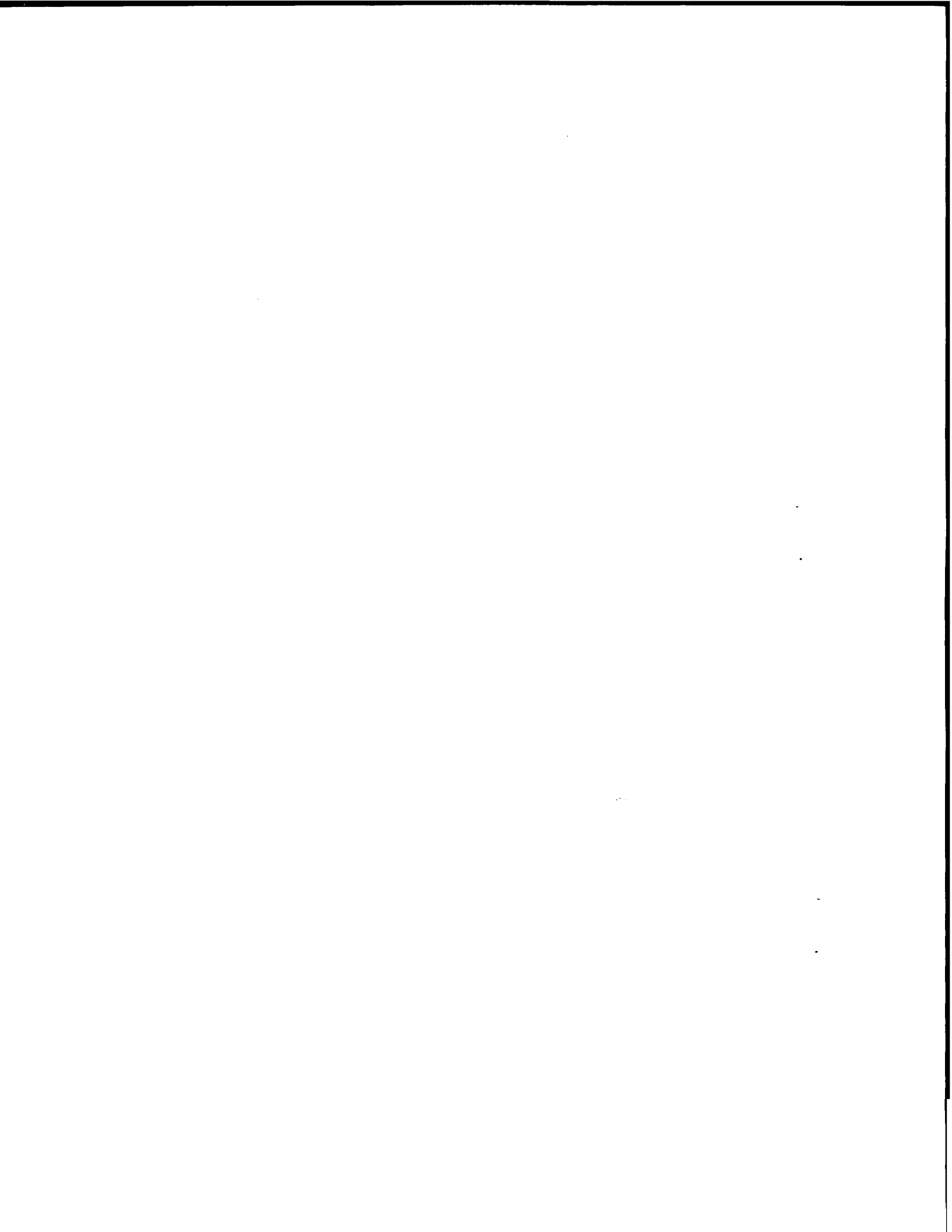

- 11) This aircraft is prohibited from aerobatic flight, that is, an intentional maneuver involving an abrupt change in the aircraft's attitude, an abnormal attitude, or abnormal acceleration not necessary for normal flight.
- 12) No person may operate this aircraft unless within the preceding 12 calendar months it has had a condition inspection performed in accordance with appendix D of part 43, or other FAA approved program, and was found to be in a condition for safe operation. This inspection will be recorded in the aircraft maintenance records.
- 13) Only FAA certificated mechanics with appropriate ratings as authorized by §43.3 may perform inspections required by these operating limitations.
- 14) Inspections must be recorded in the aircraft maintenance records showing the following, or a similar worded statement: "I certify that this aircraft has been inspected on [insert date] in accordance with the scope and detail of appendix D to part 43, or other FAA approved program, and was found to be in a condition of safe operation." The entry will include the aircraft's total time-in-service, and the name, signature, certificate held by the person performing the inspection.
- 15) This aircraft must display the word "EXPERIMENTAL" in accordance with §45.23(b).
- 16) The pilot in command of this aircraft must notify air traffic control of the experimental nature of this aircraft when operating into or out of airports with operating control towers. The pilot in command must plan routing that will avoid densely populated areas and congested airways when operating VFR.
- 17) Aircraft instruments and equipment installed and used under §91.205 must be inspected and maintained in accordance with the requirements of parts 43 and 91. Any maintenance or inspection of this equipment must be recorded in the aircraft maintenance records.
- 18) Application must be made to the Atlanta MIDO for any revision to these operating limitations.
- 19) Section §47.45 requires that the FAA Aircraft Registry must be notified within 30 days of any change in the aircraft registrant's address. Such notification is to be made by submitting Form 8050-1 to AFS-750 in Oklahoma City, Oklahoma.

July 10, 2009
Date



FAA Representative

John Hankinson

DARF501107CE
Designation

These operating Limitations have been explained, are understood and accepted

July 10, 2009
Date

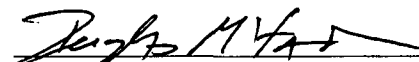
Pilot in Command

July 10, 2009
Date



Pilot in Command



FNAME

REVDATE

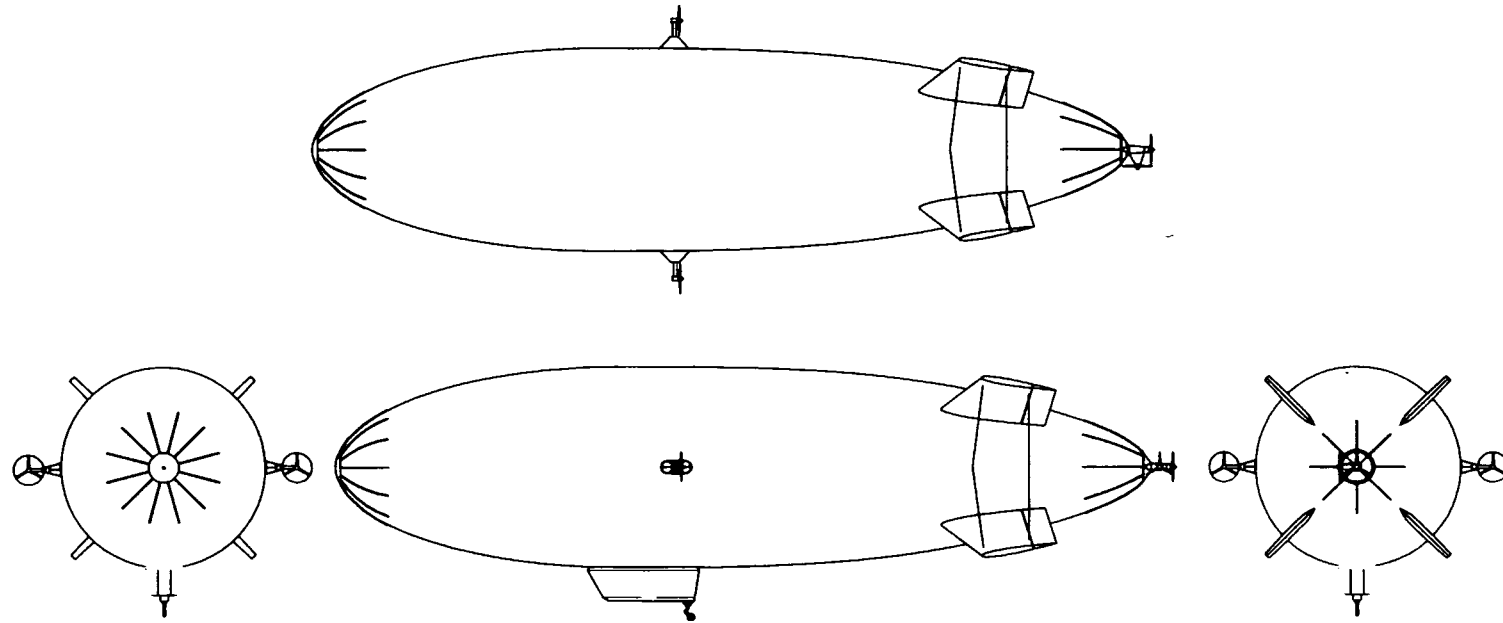
USER



REVISIONS				
ZONE	REV	DESCRIPTION	DATE	APPROVED
	A	INITIAL RERLEASE	07-08-07	-

ITEM	QTY.	PART NUMBER	DESCRIPTION	REMARKS
CAD DWG. DO NOT SCALE DRAWING				
UNLESS OTHERWISE SPECIFIED		BLACKWATER AIRSHIPS LLC		
ALL DIMENSIONS ARE IN INCHES		ELIZABETH CITY, NORTH CAROLINA 27909		
TOLERANCE				
ANGLES -1° 30'				
FRACTION 1/16"		DESCRIPTION		
DECIMALS		POLAR 400 GA		
X 1:1		MATERIAL NOTED		REV.
XX 1:20		DRAWN BY R HANCKSON		A
XXX 1:100		DATE 07-08-07		
XXXX 1:500		APPROVED		
DIMENSIONS AND TOLERANCES APPLY AFTER PLATING		DATE		
REMOVE ALL BURRS AND SHARP EDGES		D N Y		SHR
		SCALE:		1/1
		N.T.S.		

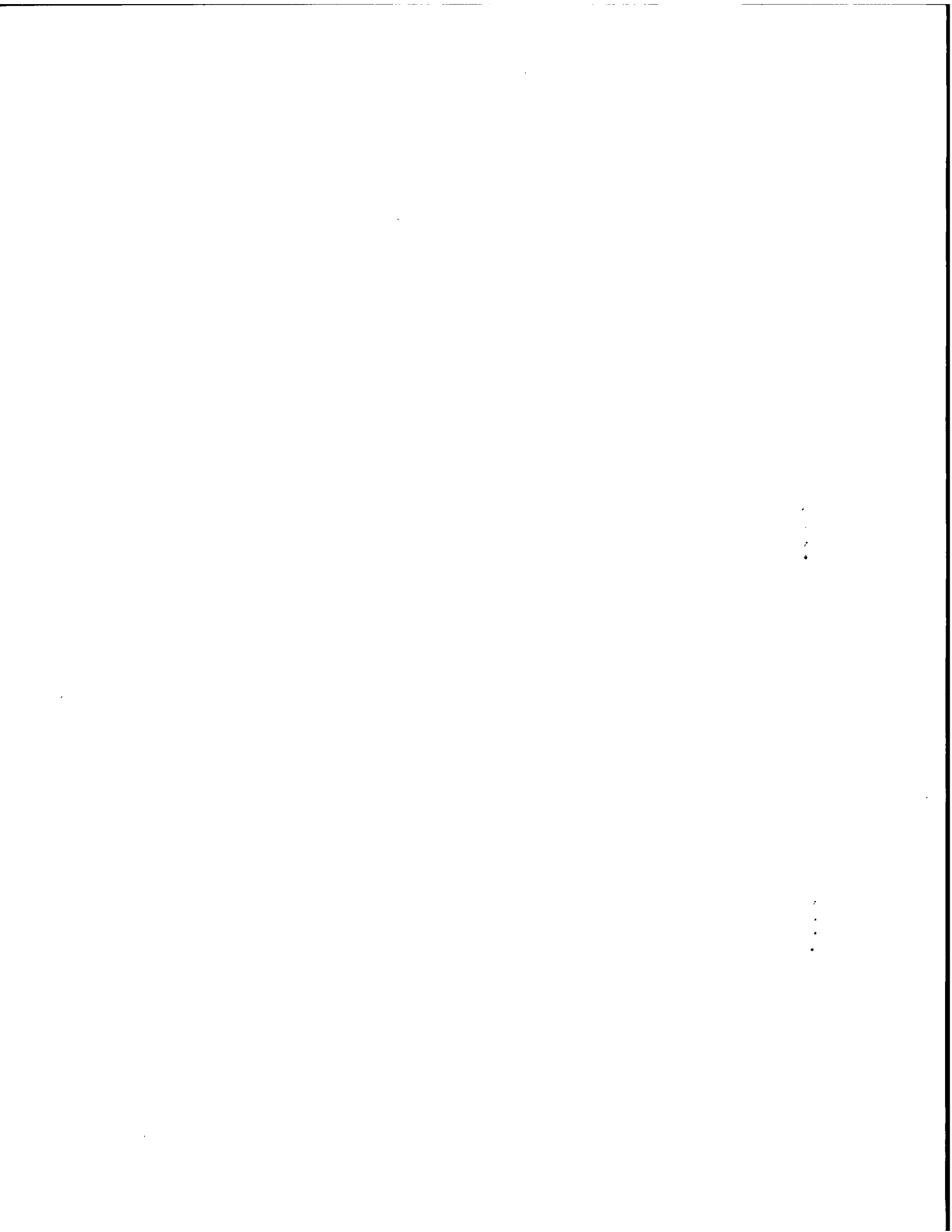

FAA FORM 8130-6, APPLICATION FOR U.S. AIRWORTHINESS CERTIFICATE

Form Approved O.M.B. No. 2120-0018
09/30/2007

Accepted NV Nov/06/2008

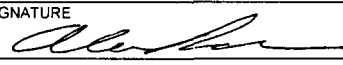
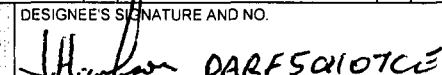
 U.S. Department of Transportation Federal Aviation Administration	<h2 style="margin: 0;">APPLICATION FOR U.S. AIRWORTHINESS CERTIFICATE</h2>	INSTRUCTIONS - Print or type. Do not write in shaded areas; these are for FAA use only. Submit original only to an authorized FAA Representative. If additional space is required, use attachment. For special flight permits complete Sections II, VI and VII as applicable.			
I. AIRCRAFT DESIGNATION	1. REGISTRATION MARK N6542B	2. AIRCRAFT BUILDER'S NAME (Make) Blackwater Airships, LLC	3. AIRCRAFT MODEL DESIGNATION Polar 400	4. YR. MFR. 2007	FAA CODING
	5. AIRCRAFT SERIAL NO. 400-001	6. ENGINE BUILDER'S NAME (Make) Thielert Aircraft Engines	7. ENGINE MODEL DESIGNATION Centurion 4.0		
	8. NUMBER OF ENGINES 1 (One)	9. PROPELLER BUILDER'S NAME (Make) MT-Propeller GmbH	10. PROPELLER MODEL DESIGNATION MTV-6-A-CR(H)/CRRD175-05		11. AIRCRAFT IS (Check if applicable) <input type="checkbox"/> EXPORT <input checked="" type="checkbox"/> IMPORT
II. CERTIFICATION REQUESTED	APPLICATION IS HEREBY MADE FOR: (Check applicable items)				
	<input type="checkbox"/> A. 1. STANDARD AIRWORTHINESS CERTIFICATE (Indicate Category)		<input type="checkbox"/> NORMAL	<input type="checkbox"/> UTILITY	<input type="checkbox"/> ACROBATIC
	<input checked="" type="checkbox"/> B. SPECIAL AIRWORTHINESS CERTIFICATE (Check appropriate items)				
	7. PRIMARY				
	9. LIGHT-SPORT (Indicate Class)		<input type="checkbox"/> AIRPLANE	<input type="checkbox"/> POWER-PARACHUTE	<input type="checkbox"/> WEIGHT-SHIFT-CONTROL
	2. LIMITED				
	5. PROVISIONAL (Indicate Class)		<input type="checkbox"/> 1. CLASS I		
			<input type="checkbox"/> 2. CLASS II		
	3. RESTRICTED (Indicate operation(s) to be conducted)		<input type="checkbox"/> 1. AGRICULTURE AND PEST CONTROL	<input type="checkbox"/> 2. AERIAL SURVEY	<input type="checkbox"/> 3. AERIAL ADVERTISING
			<input type="checkbox"/> 4. FOREST (Wildlife Conservation)	<input type="checkbox"/> 5. PATROLLING	<input type="checkbox"/> 6. WEATHER CONTROL
			<input type="checkbox"/> 0. OTHER (Specify)		
	4. EXPERIMENTAL (Indicate operation(s) to be conducted)		<input checked="" type="checkbox"/> 1. RESEARCH AND DEVELOPMENT	<input type="checkbox"/> 2. AMATEUR BUILT	<input type="checkbox"/> 3. EXHIBITION
			<input type="checkbox"/> 4. AIR RACING	<input type="checkbox"/> 5. CREW TRAINING	<input type="checkbox"/> 6. MARKET SURVEY
			<input type="checkbox"/> 0. TO SHOW COMPLIANCE WITH THE CFR	<input type="checkbox"/> 7. OPERATING (Primary Category) KIT BUILT AIRCRAFT	
			<input type="checkbox"/> 8. OPERATING LIGHT-SPORT	<input type="checkbox"/> 8A. Existing Aircraft without an airworthiness certificate & do not meet § 103.1	<input type="checkbox"/> 8B. Operating Light-Sport Kit-Built
				<input type="checkbox"/> 8C. Operating light-sport previously issued special light-sport category airworthiness certificate under § 21.190	
	8. SPECIAL FLIGHT PERMIT (Indicate operation(s) to be conducted, then complete Section VI or VII as applicable on reverse side)		<input type="checkbox"/> 1. FERRY FLIGHT FOR REPAIRS, ALTERATIONS, MAINTENANCE, OR STORAGE		
			<input type="checkbox"/> 2. EVACUATION FROM AREA OF IMPENDING DANGER		
			<input type="checkbox"/> 3. OPERATION IN EXCESS OF MAXIMUM CERTIFICATED TAKE-OFF WEIGHT		
			<input type="checkbox"/> 4. DELIVERING OR EXPORTING	<input type="checkbox"/> 5. PRODUCTION FLIGHT TESTING	
			<input type="checkbox"/> 6. CUSTOMER DEMONSTRATION FLIGHTS		
	<input type="checkbox"/> C. 6. MULTIPLE AIRWORTHINESS CERTIFICATE (check ABOVE "Restricted Operation" and "Standard" or "Limited" as applicable)				
III. OWNER'S CERTIFICATION	A. REGISTERED OWNER (As shown on certificate of aircraft registration) IF DEALER, CHECK HERE <input type="checkbox"/>				
	NAME Blackwater Airships, LLC		ADDRESS PO Box 1029, Moyock NC 27958-1029		
	B. AIRCRAFT CERTIFICATION BASIS (Check applicable blocks and complete items as indicated)				
	AIRCRAFT SPECIFICATION OR TYPE CERTIFICATE DATA SHEET (Give No. and Revision No.) N/A		AIRWORTHINESS DIRECTIVES (Check if all applicable AD's are complied with and give the number of the last AD SUPPLEMENT available in the biweekly series as of the date of application) N/A		
	AIRCRAFT LISTING (Give page number(s)) N/A		SUPPLEMENTAL TYPE CERTIFICATE (List number of each STC incorporated) N/A		
	C. AIRCRAFT OPERATION AND MAINTENANCE RECORDS				
	CHECK IF RECORDS IN COMPLIANCE WITH 14 CFR Section 91.417	TOTAL AIRFRAME HOURS 55.5	<input type="checkbox"/> 3. EXPERIMENTAL ONLY (Enter hours flown since last certificate issued or renewed) 55.5		
	D. CERTIFICATION - I hereby certify that I am the registered owner (or his agent) of the aircraft described above, that the aircraft is registered with the Federal Aviation Administration in accordance with Title 49 of the United States Code 44101 et seq. and applicable Federal Aviation Regulations, and that the aircraft has been inspected and is airworthy and eligible for the airworthiness certificate requested.				
	DATE OF APPLICATION August 28, 2008	NAME AND TITLE (Print or type) Alan Ram (Vice President)	SIGNATURE 		
IV. INSPECTION AGENCY VERIFICATION	A. THE AIRCRAFT DESCRIBED ABOVE HAS BEEN INSPECTED AND FOUND AIRWORTHY BY: (Complete the section only if 14 CFR part 21.183(d) applies)				
	<input type="checkbox"/> 2. 14 CFR part 121 CERTIFICATE HOLDER (Give Certificate No.)	<input type="checkbox"/> 3. CERTIFICATED MECHANIC (Give Certificate No.)	<input type="checkbox"/> 6. CERTIFICATED REPAIR STATION (Give Certificate No.)		
	<input type="checkbox"/> 5. AIRCRAFT MANUFACTURER (Give name or firm)				
	DATE	TITLE	SIGNATURE		
V. FAA REPRESENTATIVE CERTIFICATION	(Check ALL applicable block items A and B)				
	A. I find that the aircraft described in Section I or VII meets requirements for		THE CERTIFICATE REQUESTED		
	B. Inspection for a special permit under Section VII was conducted by:		AMENDMENT OR MODIFICATION OF CURRENT AIRWORTHINESS CERTIFICATE		
		FAA INSPECTOR	FAA DESIGNEE		
		CERTIFICATE HOLDER UNDER	<input type="checkbox"/> 14 CFR part 65	<input type="checkbox"/> 14 CFR part 121 OR 135	<input type="checkbox"/> 14 CFR part 145
	DATE 9/5/2008	DISTRICT OFFICE Atlanta MIDO	DESIGNEE'S SIGNATURE AND NO. 		FAA INSPECTOR'S SIGNATURE

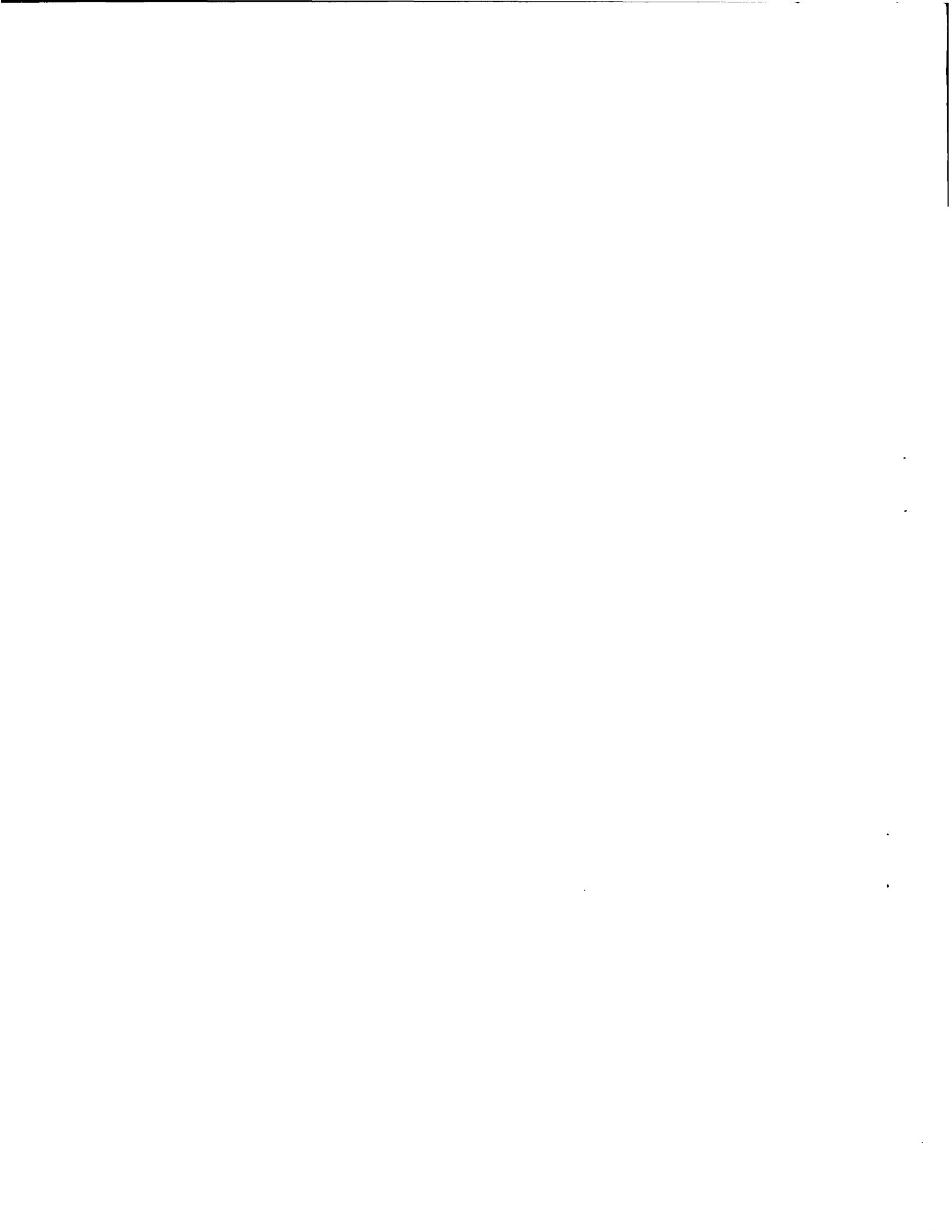

VI. PRODUCTION FLIGHT TESTING	A. MANUFACTURER				
	NAME		ADDRESS		
	B. PRODUCTION BASIS <i>(Check applicable item)</i>				
	<input type="checkbox"/> PRODUCTION CERTIFICATE <i>(Give production certificate number)</i>		<input type="checkbox"/> TYPE CERTIFICATE ONLY		
	<input type="checkbox"/> APPROVED PRODUCTION INSPECTION SYSTEM				
	C. GIVE QUANTITY OF CERTIFICATES REQUIRED FOR OPERATING NEEDS				
DATE OF APPLICATION		NAME AND TITLE <i>(Print or Type)</i>	SIGNATURE		
VII. SPECIAL FLIGHT PERMIT PURPOSES OTHER THAN PRODUCTION FLIGHT TEST	A. DESCRIPTION OF AIRCRAFT				
	REGISTERED OWNER		ADDRESS		
	BUILDER <i>(Make)</i>		MODEL		
	SERIAL NUMBER		REGISTRATION MARK		
	B. DESCRIPTION OF FLIGHT				
	FROM		TO		
	VIA		DEPARTURE DATE	DURATION	
	C. CREW REQUIRED TO OPERATE THE AIRCRAFT AND ITS EQUIPMENT				
		PILOT	CO-PILOT	FLIGHT ENGINEER	OTHER <i>(Specify)</i>
	D. THE AIRCRAFT DOES NOT MEET THE APPLICABLE AIRWORTHINESS REQUIREMENTS AS FOLLOWS:				
	E. THE FOLLOWING RESTRICTIONS ARE CONSIDERED NECESSARY FOR SAFE OPERATION: <i>(Use attachment if necessary)</i>				
F. CERTIFICATION – I hereby certify that I am the registered owner (or his agent) of the aircraft described above; that the aircraft is registered with the Federal Aviation Administration in accordance with Title 49 of the United States Code 44101 et seq. and applicable Federal Aviation Regulations; and that the aircraft has been inspected and is safe for the flight described.					
DATE		NAME AND TITLE <i>(Print or Type)</i>	SIGNATURE		
VIII. AIRWORTHINESS DOCUMENTATION (FAA-DESIGNEE use only)	A. Operating Limitations and Markings in Compliance with 14 CFR Section 91.9, as applicable.		G. Statement of Conformity, FAA Form 8130-9 <i>(Attach when required)</i>		
	<input checked="" type="checkbox"/>	B. Current Operating Limitations Attached	H. Foreign Airworthiness Certification for Import Aircraft <i>(Attach when required)</i>		
	<input checked="" type="checkbox"/>	C. Data, Drawings, Photographs, etc. <i>(Attach when required)</i>	<input checked="" type="checkbox"/>		
	<input checked="" type="checkbox"/>	D. Current Weight and Balance information Available in Aircraft	I. Previous Airworthiness Certificate Issued in Accordance with 14 CFR Section 21.191 (a) CAR _____ <i>(Original Attached)</i>		
	<input checked="" type="checkbox"/>	E. Major Repair and Alteration, FAA Form 337 <i>(Attach when required)</i>	<input checked="" type="checkbox"/>		
	<input checked="" type="checkbox"/>	F. This inspection Recorded in Aircraft Records	J. Current Airworthiness Certificate Issued in Accordance with 14 CFR Section 21.191 (a) _____ <i>(Copy Attached)</i>		
<input checked="" type="checkbox"/>		K. Light-Sport Aircraft Statement of Compliance, FAA Form 8130-15 <i>(Attach when required)</i>			

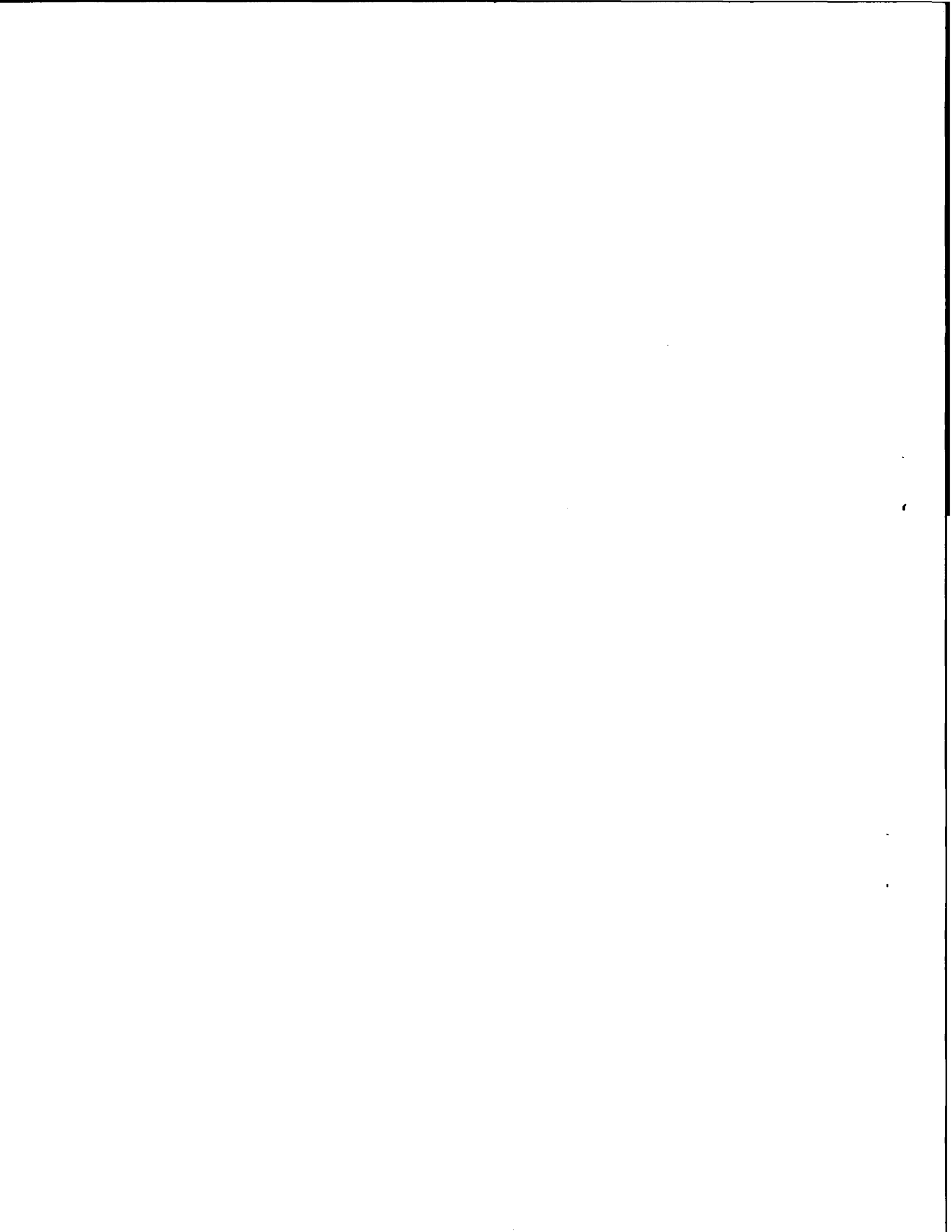

UNITED STATES OF AMERICA
 DEPARTMENT OF TRANSPORTATION - FEDERAL AVIATION ADMINISTRATION
SPECIAL AIRWORTHINESS CERTIFICATE

A	CATEGORY/DESIGNATION EXPERIMENTAL	
	PURPOSE RESEARCH AND DEVELOPMENT	
B	MANUFACTURER NAME	N/A
	ADDRESS	N/A
C	FLIGHT FROM	N/A
	TO	N/A
D	N- 6542B	SERIAL NO. 400-001
	BUILDER BLACKWATER AIRSHIP SLIC	MODEL POLAR 400
E	DATE OF ISSUANCE SEPT 5, 2008	EXPIRY SEPT 4, 2009
	OPERATING LIMITATIONS DATED SEPT 5, 2008 ARE A PART OF THIS CERTIFICATE	
	SIGNATURE OF FAA REPRESENTATIVE J. HANKINSON <i>J. Hankinson</i>	DESIGNATION OR OFFICE NO. DARF501107CE

Any alteration, reproduction or misuse of this certificate may be punishable by a fine not exceeding \$1,000 or imprisonment not exceeding 3 years, or both. THIS CERTIFICATE MUST BE DISPLAYED IN THE AIRCRAFT IN ACCORDANCE WITH APPLICABLE FEDERAL AVIATION REGULATIONS.

A	This airworthiness certificate is issued under the authority of the Federal Aviation Act of 1958 and the Federal Aviation Regulations (FAR).
B	This airworthiness certificate authorizes the manufacturer named on the reverse side to conduct production flight tests, and only production flight tests, of aircraft registered in his name. No person may conduct production flight tests under this certificate: (1) Carrying persons or property for compensation or hire; and/or (2) Carrying persons not essential to the purpose of the flight.
C	This airworthiness certificate authorizes the flight specified on the reverse side for the purpose shown in Block A.
D	This airworthiness certificate certifies that, as of the date of issuance, the aircraft to which issued has been inspected and found to meet the requirements of the applicable FAR. The aircraft does not meet the requirements of the applicable comprehensive and detailed airworthiness code as provided by Annex 8 to the Convention On International Civil Aviation. No person may operate the aircraft described on the reverse side: (1) except in accordance with the applicable FAR and in accordance with conditions and limitations which may be prescribed by the Administrator as part of this certificate; (2) over any foreign country without the special permission of that country.
E	Unless sooner surrendered, suspended, or revoked, this airworthiness certificate is effective for the duration and under the conditions prescribed in FAR Part 21, Section 21.181 or 21.217.

UNITED STATES OF AMERICA
DEPARTMENT OF TRANSPORTATION - FEDERAL AVIATION ADMINISTRATION
SPECIAL AIRWORTHINESS CERTIFICATE

A	CATEGORY/DESIGNATION	EXPERIMENTAL	
	PURPOSE	RESEARCH AND DEVELOPMENT	
B	MANUFACTURER	NAME	N/A
		ADDRESS	N/A
C	FLIGHT	FROM	N/A
		TO	N/A
D	N-6542B	SERIAL NO.	400-001
	BUILDER BLACKWATER AIRSHIPS LLC	MODEL	POLAR 400
E	DATE OF ISSUANCE	NOV 7 2007	EXPIRY NOV 6 2008
	OPERATING LIMITATIONS DATED NOV 7 2007 ARE A PART OF THIS CERTIFICATE		
SIGNATURE OF FAA REPRESENTATIVE		DESIGNATION OR OFFICE NO.	
J SHANKINSON <i>J. Shankinson</i>		DARF501107CE	

Any alteration, reproduction or misuse of this certificate may be punishable by a fine not exceeding \$1,000 or imprisonment not exceeding 3 years, or both. THIS CERTIFICATE MUST BE DISPLAYED IN THE AIRCRAFT IN ACCORDANCE WITH APPLICABLE FEDERAL AVIATION REGULATIONS.

A	This airworthiness certificate is issued under the authority of the Federal Aviation Act of 1958 and the Federal Aviation Regulations (FAR).
B	This airworthiness certificate authorizes the manufacturer named on the reverse side to conduct production flight tests, and only production flight tests, of aircraft registered in his name. No person may conduct production flight tests under this certificate: (1) Carrying persons or property for compensation or hire; and/or (2) Carrying persons not essential to the purpose of the flight.
C	This airworthiness certificate authorizes the flight specified on the reverse side for the purpose shown in Block A.
D	This airworthiness certificate certifies that, as of the date of issuance, the aircraft to which issued has been inspected and found to meet the requirements of the applicable FAR. The aircraft does not meet the requirements of the applicable comprehensive and detailed airworthiness code as provided by Annex 8 to the Convention On International Civil Aviation. No person may operate the aircraft described on the reverse side: (1) except in accordance with the applicable FAR and in accordance with conditions and limitations which may be prescribed by the Administrator as part of this certificate; (2) over any foreign country without the special permission of that country.
E	Unless sooner surrendered, suspended, or revoked, this airworthiness certificate is effective for the duration and under the conditions prescribed in FAR Part 21, Section 21.181 or 21.217.

FNAME

REVDATE

USER

REVISIONS				
ZONE	REV	DESCRIPTION	DATE	APPROVED
	A	INITIAL RERLEASE	07-08-07	-

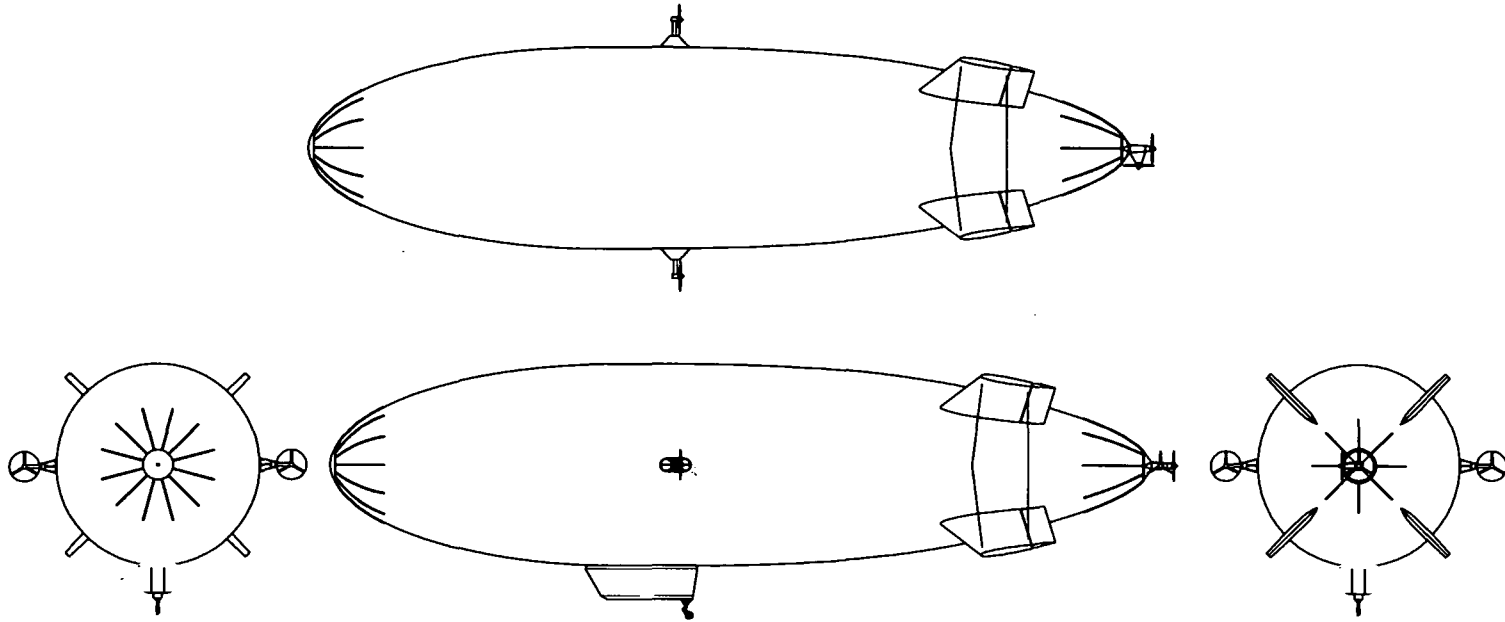

ITEM	QTY.	PART NUMBER	DESCRIPTION	REMARKS
CAD DWG. DO NOT SCALE DRAWING				
UNLESS OTHERWISE SPECIFIED ALL DIMENSIONS ARE IN INCHES TOLERANCE ANGLES ±0° 30' FRACTION ±1/64 DECIMALS .X ±.1 .XX ±.02 .XXX ±.005 .XXXX ±.0005		BLACKWATER  BLACKWATER AIRSHIPS LLC ELIZABETH CITY, NORTH CAROLINA 27909		
MATERIAL NOTED DRAWN BY R HANCKINSON DATE 07-08-07 APPROVED NAME DATE D M Y		DESCRIPTION POLAR 400 GA SIZE PART NO. D 400-00-008 SCALE: N.T.S.		REV. A SHT. 1/1





U.S. Department
of Transportation

Federal Aviation
Administration

**SPECIAL
EXPERIMENTAL
RESEARCH and DEVELOPMENT
OPERATING LIMITATIONS**

MAKE: Blackwater Airships, LLC

MODEL: Polar 400

SERIAL NUMBER: 400-001

REG. NUMBER: N6542B

Date Issued: September 5, 2008

Expiration Date: September 4, 2009

- 1) No person may operate this aircraft unless Form 8130-7 is displayed at the cockpit entrance and visible to flight crew members.
- 2) No person may operate this aircraft for other than the purpose of Research and Development, to accomplish the flight operation outlined in the program letter dated August 28, 2008, which describes compliance with §21.193(d), and has been made available to the pilot in command of the aircraft. In addition, this aircraft must be operated in accordance with applicable air traffic and general operating rules of part 91, and all additional limitations herein prescribed under provisions of §91.319(e).
- 3) All flights of this aircraft must be conducted over open water or sparsely populated areas having light air traffic, within the geographic area described as follows: Within 150 nautical mile radius of the former Weeksville, NC Naval Air Station (EKV) 36°13'59.19"N, 76°08'0.01"W.
- 4) This aircraft must not be operated unless it is inspected and maintained in accordance with the manufacturers recommendations. The owner/operator must select, establish, identify, and use an inspection program as set forth in §91.409(e), (f), (g) and (h). This inspection program must be recorded in the aircraft maintenance records.
- 5) The pilot in command of this aircraft must hold an appropriate category/class rating. If required for the type of aircraft to be flown, the pilot in command also must hold either an appropriate type rating or a letter of authorization issued by an FAA Flight Standards Operations Inspector.
- 6) This aircraft is to be operated under VFR, day and/or night.
- 7) No person may operate this aircraft for carrying persons or property for compensation or hire.
- 8) No person may be carried in this aircraft during flight unless that person is essential to the purpose of the flight.
- 9) The pilot in command of this aircraft must advise each passenger of the experimental nature of this aircraft, and explain that it does not meet the certification requirements of a standard certificated aircraft.
- 10) This aircraft must contain the placards, markings, etc. required by §91.9(c).
- 11) This aircraft is prohibited from aerobatic flight, that is, an intentional maneuver involving an abrupt change in the aircrafts attitude, an abnormal attitude, or abnormal acceleration not necessary for normal flight.

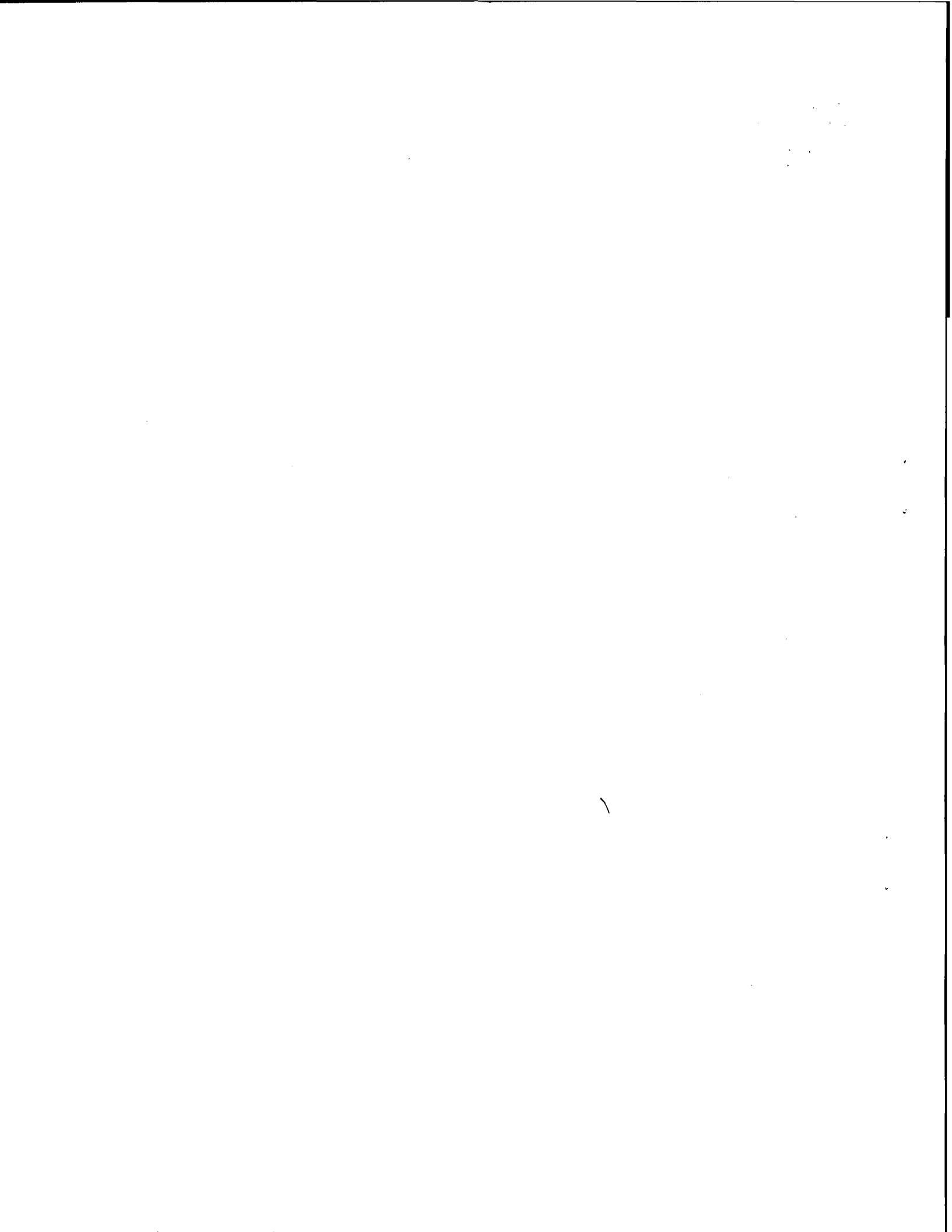

- 12) No person may operate this aircraft unless within the preceding 12 calendar months it has had a condition inspection performed in accordance with appendix D of part 43, or other FAA approved program, and was found to be in a condition for safe operation. This inspection will be recorded in the aircraft maintenance records.
- 13) Only FAA certificated mechanics with appropriate ratings as authorized by §43.3 may perform inspections required by these operating limitations.
- 14) Inspections must be recorded in the aircraft maintenance records showing the following, or a similar worded statement: "I certify that this aircraft has been inspected on [insert date] in accordance with the scope and detail of appendix D to part 43, or other FAA approved program, and was found to be in a condition of safe operation." The entry will include the aircraft's total time-in-service, and the name, signature, certificate held by the person performing the inspection.
- 15) This aircraft must display the word "EXPERIMENTAL" in accordance with §45.23(b).
- 16) The pilot in command of this aircraft must notify air traffic control of the experimental nature of this aircraft when operating into or out of airports with operating control towers. The pilot in command must plan routing that will avoid densely populated areas and congested airways when operating VFR.
- 17) Aircraft instruments and equipment installed and used under §91.205 must be inspected and maintained in accordance with the requirements of parts 43 and 91. Any maintenance or inspection of this equipment must be recorded in the aircraft maintenance records.
- 18) Application must be made to the Atlanta MIDO for any revision to these operating limitations.
- 19) Section §47.45 requires that the FAA Aircraft Registry must be notified within 30 days of any change in the aircraft registrant's address. Such notification is to be made by submitting Form 8050-1 to AFS-750 in Oklahoma City, Oklahoma.

September 5, 2008

Date

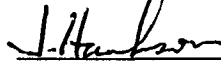

FAA Representative

John Hankinson

DARF501107CE

Designation

These operating Limitations have been explained, are understood and accepted

September 5, 2008

Date



Pilot in Command

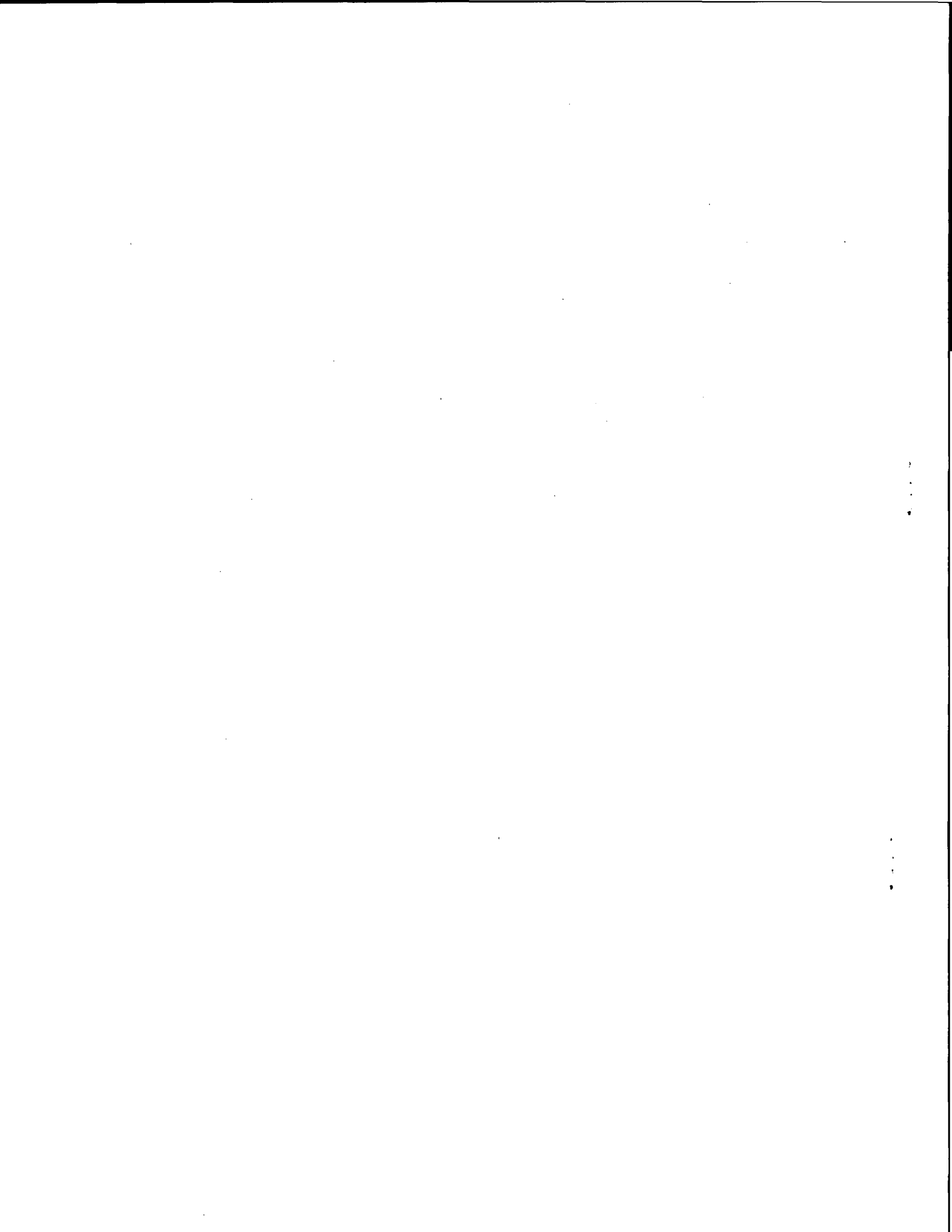

FAA FORM 8130-6, APPLICATION FOR U.S. AIRWORTHINESS CERTIFICATE

Form Approved O.M.B. No. 2120-0018
09/30/2007

Accepted KA Jul/14/2008

 U.S. Department of Transportation Federal Aviation Administration	<h2 style="margin: 0;">APPLICATION FOR U.S. AIRWORTHINESS CERTIFICATE</h2>				INSTRUCTIONS - Print or type. Do not write in shaded areas; these are for FAA use only. Submit original only to an authorized FAA Representative. If additional space is required, use attachment. For special flight permits complete Sections II, VI and VII as applicable.							
	1. REGISTRATION MARK	N6542B	2. AIRCRAFT BUILDER'S NAME (Make)	Blackwater Airships, LLC	3. AIRCRAFT MODEL DESIGNATION	Polar 400	4. YR. MFR.	2007	FAA CODING: 061001L 59304			
	5. AIRCRAFT SERIAL NO.	400-001	6. ENGINE BUILDER'S NAME (Make)	Thielert	7. ENGINE MODEL DESIGNATION	Centurian 4.0						
8. NUMBER OF ENGINES	1 (one)	9. PROPELLER BUILDER'S NAME (Make)	MT-Propeller	10. PROPELLER MODEL DESIGNATION	MTV-6-A-CR(H)/CRRD175-05							
								11. AIRCRAFT IS (Check if applicable)				
								IMPORT				
APPLICATION IS HEREBY MADE FOR: (Check applicable items)												
A	1	STANDARD AIRWORTHINESS CERTIFICATE (Indicate Category)				NORMAL	UTILITY	ACROBATIC	TRANSPORT	COMMAUTER		
B	✓	SPECIAL AIRWORTHINESS CERTIFICATE (Check appropriate items)										
II. CERTIFICATION REQUESTED	7	PRIMARY										
	9	LIGHT-SPORT (Indicate Class)		AIRPLANE	POWER-PARACHUTE	WEIGHT-SHIFT-CONTROL	GLIDER	LIGHTER THAN AIR				
	2	LIMITED										
	5	PROVISIONAL (Indicate Class)		1	CLASS I			2	CLASS II			
	3	3	RESTRICTED (Indicate operation(s) to be conducted)	1	AGRICULTURE AND PEST CONTROL		2	AERIAL SURVEY		3	AERIAL ADVERTISING	
				4	FOREST (Wildlife Conservation)		5	PATROLLING		6	WEATHER CONTROL	
				0	OTHER (Specify)							
	4	✓	EXPERIMENTAL (Indicate operation(s) to be conducted)	1	RESEARCH AND DEVELOPMENT		2	AMATEUR BUILT		3	EXHIBITION	
				4	AIR RACING		5	CREW TRAINING		6	MARKET SURVEY	
				0	TO SHOW COMPLIANCE WITH THE CFR							
	8	✓	SPECIAL FLIGHT PERMIT (Indicate operation(s) to be conducted, then complete Section VI or VII as applicable on reverse side)	1	OPERATING LIGHT-SPORT		8A	Existing Aircraft without an airworthiness certificate & do not meet § 103.1				
				8			8B	Operating Light-Sport Kit-Built				
				8			8C	Operating light-sport previously issued special light-sport category airworthiness certificate under § 21.190				
	8	✓	SPECIAL FLIGHT PERMIT (Indicate operation(s) to be conducted, then complete Section VI or VII as applicable on reverse side)	1	FERRY FLIGHT FOR REPAIRS, ALTERATIONS, MAINTENANCE, OR STORAGE							
				2	EVACUATION FROM AREA OF IMPENDING DANGER							
3				OPERATION IN EXCESS OF MAXIMUM CERTIFICATED TAKE-OFF WEIGHT								
4				DELIVERING OR EXPORTING		5	PRODUCTION FLIGHT TESTING					
6				CUSTOMER DEMONSTRATION FLIGHTS								
6				MULTIPLE AIRWORTHINESS CERTIFICATE (check ABOVE "Restricted Operation" and "Standard" or "Limited" as applicable)								
III. OWNER'S CERTIFICATION	A. REGISTERED OWNER (As shown on certificate of aircraft registration)					IF DEALER, CHECK HERE <input type="checkbox"/>						
	NAME Blackwater Airships, LLC.					ADDRESS PO Box 1029, Moyock NC 27958-1029						
	B. AIRCRAFT CERTIFICATION BASIS (Check applicable blocks and complete items as indicated)											
	AIRCRAFT SPECIFICATION OR TYPE CERTIFICATE DATA SHEET (Give No. and Revision No.) N/A					AIRWORTHINESS DIRECTIVES (Check if all applicable AD's are complied with and give the number of the last AD SUPPLEMENT available in the biweekly series as of the date of application) N/A						
	AIRCRAFT LISTING (Give page number(s)) N/A					SUPPLEMENTAL TYPE CERTIFICATE (List number of each STC incorporated) N/A						
C. AIRCRAFT OPERATION AND MAINTENANCE RECORDS												
CHECK IF RECORDS IN COMPLIANCE WITH 14 CFR Section 91.417			TOTAL AIRFRAME HOURS 0			EXPERIMENTAL ONLY (Enter hours flown since last certificate issued or renewed) 0						
D. CERTIFICATION - I hereby certify that I am the registered owner (or his agent) of the aircraft described above, that the aircraft is registered with the Federal Aviation Administration in accordance with Title 49 of the United States Code 44101 et seq. and applicable Federal Aviation Regulations, and that the aircraft has been inspected and is airworthy and eligible for the airworthiness certificate requested.												
DATE OF APPLICATION 11 October 2007			NAME AND TITLE (Print or type) Hank Steenstra (Vice President)				SIGNATURE 					
IV. INSPECTION AGENCY VERIFICATION	A. THE AIRCRAFT DESCRIBED ABOVE HAS BEEN INSPECTED AND FOUND AIRWORTHY BY: (Complete the section only if 14 CFR part 21.183(d) applies.)											
	2	14 CFR part 121 CERTIFICATE HOLDER (Give Certificate No.)		3	CERTIFICATED MECHANIC (Give Certificate No.)		6	CERTIFICATED REPAIR STATION (Give Certificate No.)				
	5	AIRCRAFT MANUFACTURER (Give name or firm)										
DATE			TITLE				SIGNATURE					
V. FAA REPRESENTATIVE CERTIFICATION	(Check ALL applicable block items A and B)				<input checked="" type="checkbox"/> THE CERTIFICATE REQUESTED <input type="checkbox"/> AMENDMENT OR MODIFICATION OF CURRENT AIRWORTHINESS CERTIFICATE							
	A. I find that the aircraft described in Section I or VII meets requirements for											
	B. Inspection for a special permit under Section VII was conducted by:				FAA INSPECTOR		FAA DESIGNEE					
					CERTIFICATE HOLDER UNDER		14 CFR part 65		14 CFR part 121 OR 135		14 CFR part 145	
DATE 11/7/2007		DISTRICT OFFICE Atlanta MIDO		DESIGNEE'S SIGNATURE AND NO. DAF501107CE				FAA INSPECTOR'S SIGNATURE				

10/10/10

VI. PRODUCTION FLIGHT TESTING	A. MANUFACTURER			
	NAME		ADDRESS	
	B. PRODUCTION BASIS <i>(Check applicable item)</i>			
	<input type="checkbox"/> PRODUCTION CERTIFICATE <i>(Give production certificate number)</i> —————→		<input type="checkbox"/> TYPE CERTIFICATE ONLY	
	<input type="checkbox"/> APPROVED PRODUCTION INSPECTION SYSTEM			
C. GIVE QUANTITY OF CERTIFICATES REQUIRED FOR OPERATING NEEDS				
DATE OF APPLICATION		NAME AND TITLE <i>(Print or Type)</i>		SIGNATURE
VII. SPECIAL FLIGHT PERMIT PURPOSES OTHER THAN PRODUCTION FLIGHT TEST	A. DESCRIPTION OF AIRCRAFT			
	REGISTERED OWNER		ADDRESS	
	BUILDER <i>(Make)</i>		MODEL	
	SERIAL NUMBER		REGISTRATION MARK	
	B. DESCRIPTION OF FLIGHT			
	FROM		TO	
	VIA		DEPARTURE DATE	DURATION
	C. CREW REQUIRED TO OPERATE THE AIRCRAFT AND ITS EQUIPMENT			
	<input type="checkbox"/> PILOT		<input type="checkbox"/> CO-PILOT	
	<input type="checkbox"/> FLIGHT ENGINEER		<input type="checkbox"/> OTHER <i>(Specify)</i>	
	D. THE AIRCRAFT DOES NOT MEET THE APPLICABLE AIRWORTHINESS REQUIREMENTS AS FOLLOWS:			
E. THE FOLLOWING RESTRICTIONS ARE CONSIDERED NECESSARY FOR SAFE OPERATION: <i>(Use attachment if necessary)</i>				
F. CERTIFICATION — I hereby certify that I am the registered owner (or his agent) of the aircraft described above; that the aircraft is registered with the Federal Aviation Administration in accordance with Title 49 of the United States Code 44101 <u>et seq.</u> , and applicable Federal Aviation Regulations; and that the aircraft has been inspected and is safe for the flight described.				
DATE		NAME AND TITLE <i>(Print or Type)</i>		SIGNATURE
VIII. AIRWORTHINESS DOCUMENTATION (FAA DESIGNEE use only)	A. Operating Limitations and Markings in Compliance with 14 CFR Section 91.9, as applicable.		G. Statement of Conformity, FAA Form 8130-9 <i>(Attach when required)</i>	
	✓ B. Current Operating Limitations Attached		H. Foreign Airworthiness Certification for Import Aircraft <i>(Attach when required)</i>	
	C. Data, Drawings, Photographs, etc. <i>(Attach when required)</i>		I. Previous Airworthiness Certificate Issued in Accordance with 14 CFR Section _____ CAR _____ <i>(Original Attached)</i>	
	✓ D. Current Weight and Balance Information Available in Aircraft		✓ J. Current Airworthiness Certificate Issued in Accordance with 14 CFR Section 21.191 (a) _____ <i>(Copy Attached)</i>	
	E. Major Repair and Alteration, FAA Form 337 <i>(Attach when required)</i>		K. Light-Sport Aircraft Statement of Compliance, FAA Form 8130-15 <i>(Attach when required)</i>	
	✓ F. This Inspection Recorded in Aircraft Records			

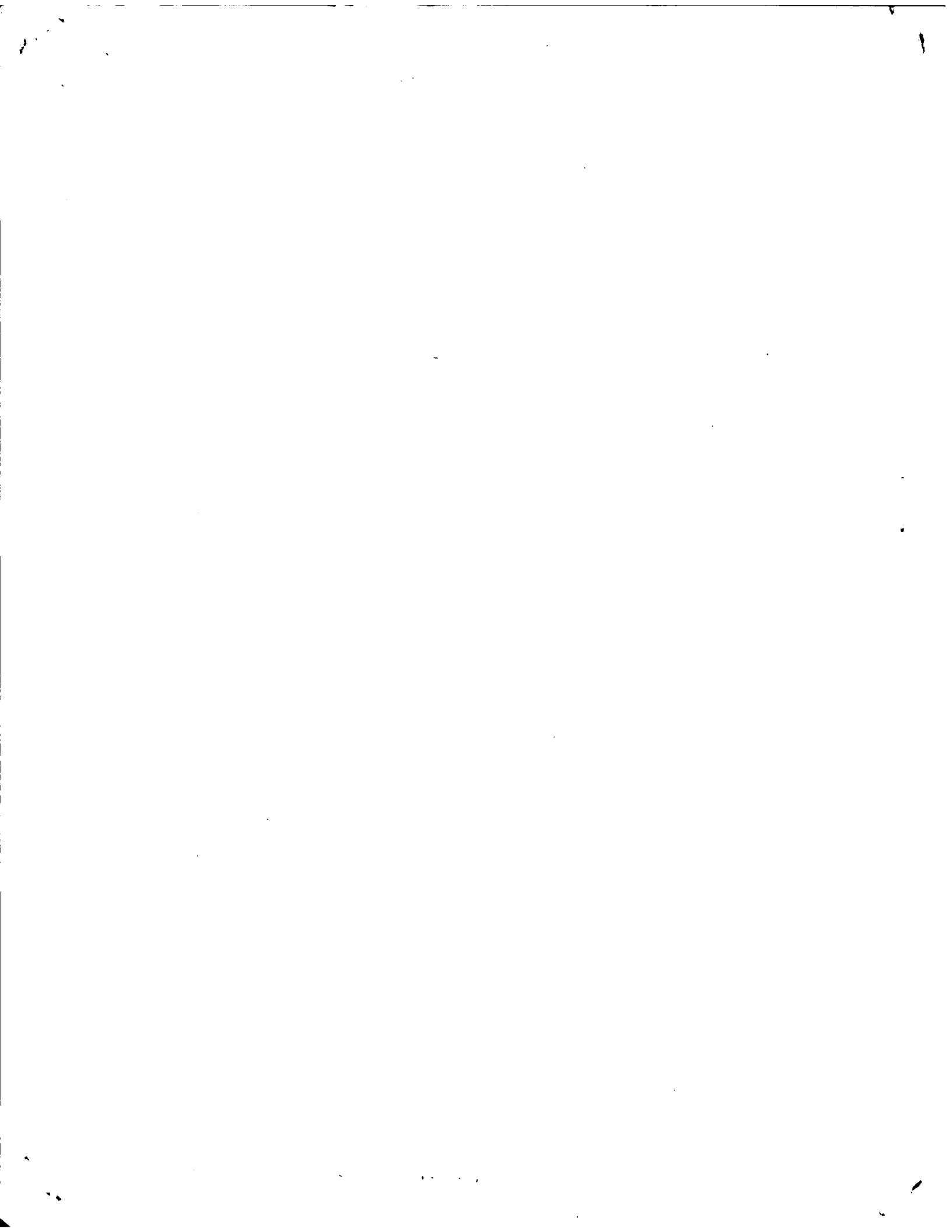

UNITED STATES OF AMERICA
DEPARTMENT OF TRANSPORTATION - FEDERAL AVIATION ADMINISTRATION
SPECIAL AIRWORTHINESS CERTIFICATE

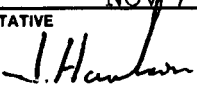
A	CATEGORY/DESIGNATION EXPERIMENTAL	
	PURPOSE RESEARCH AND DEVELOPMENT	
B	MANUFACTURER	NAME N/A
		ADDRESS N/A
C	FLIGHT	FROM N/A
		TO N/A
D	N- 6542B	SERIAL NO. 400-001
	BUILDER BLACKWATER AIRSHIPS LLC	MODEL POLAR 400
E	DATE OF ISSUANCE NOV 7 2007	EXPIRY NOV 6 2008
	OPERATING LIMITATIONS DATED NOV 7 2007 ARE A PART OF THIS CERTIFICATE	
	SIGNATURE OF FAA REPRESENTATIVE	DESIGNATION OR OFFICE NO.
	J. HANKINSON 	DARF501107CE

Any alteration, reproduction or misuse of this certificate may be punishable by a fine not exceeding \$1,000 or imprisonment not exceeding 3 years, or both. THIS CERTIFICATE MUST BE DISPLAYED IN THE AIRCRAFT IN ACCORDANCE WITH APPLICABLE FEDERAL AVIATION REGULATIONS.

A	This airworthiness certificate is issued under the authority of the Federal Aviation Act of 1958 and the Federal Aviation Regulations (FAR).
B	This airworthiness certificate authorizes the manufacturer named on the reverse side to conduct production flight tests, and only production flight tests, of aircraft registered in his name. No person may conduct production flight tests under this certificate: (1) Carrying persons or property for compensation or hire; and/or (2) Carrying persons not essential to the purpose of the flight.
C	This airworthiness certificate authorizes the flight specified on the reverse side for the purpose shown in Block A.
D	This airworthiness certificate certifies that, as of the date of issuance, the aircraft to which issued has been inspected and found to meet the requirements of the applicable FAR. The aircraft does not meet the requirements of the applicable comprehensive and detailed airworthiness code as provided by Annex 8 to the Convention On International Civil Aviation. No person may operate the aircraft described on the reverse side: (1) except in accordance with the applicable FAR and in accordance with conditions and limitations which may be prescribed by the Administrator as part of this certificate; (2) over any foreign country without the special permission of that country.
E	Unless sooner surrendered, suspended, or revoked, this airworthiness certificate is effective for the duration and under the conditions prescribed in FAR Part 21, Section 21.181 or 21.217.



U.S. Department
of Transportation

Federal Aviation
Administration

**SPECIAL
EXPERIMENTAL
RESEARCH and DEVELOPMENT
OPERATING LIMITATIONS**

MAKE: Blackwater Airships, LLC

MODEL: Polar 400

SERIAL NUMBER: 400-001

REG. NUMBER: N6542B

DATE ISSUED: Nov. 7, 2007

EXPIRATION: Nov. 6, 2008

- 1) No person may operate this aircraft unless Form 8130-7 is displayed at the cabin or cockpit entrance and visible to flight crew members.
- 2) No person may operate this aircraft for other than the purpose of Research and Development, to accomplish the flight operation outlined in the program letter dated October 1, 2007, which describes compliance with 21.193(d), and has been made available to the pilot in command of the aircraft. In addition, this aircraft must be operated in accordance with applicable air traffic and general operating rules of part 91, and all additional limitations herein prescribed under provisions of 91.319(e).
- 3) All flights of this aircraft must be conducted over open water or sparsely populated areas having light air traffic, within the geographic area described as follows: Within 50 nautical mile radius of the former Weeksville, NC Naval Air Station (EKV) 36°13'59.19"N, 76°08'0.01"W.
- 4) This aircraft must not be operated unless it is inspected and maintained in accordance with the manufacturers recommendations. The owner/operator must select, establish, identify, and use an inspection program as set forth in 91.409(e), (f), (g) and (h). This inspection program must be recorded in the aircraft maintenance records.
- 5) The pilot in command of this aircraft must hold an appropriate category/class rating. If required for the type of aircraft to be flown, the pilot in command also must hold either an appropriate type rating or a letter of authorization issued by an FAA Flight Standards Operations Inspector.
- 6) This aircraft is to be operated under VFR, day and/or night.
- 7) No person may operate this aircraft for carrying persons or property for compensation or hire.
- 8) No person may be carried in this aircraft during flight unless that person is essential to the purpose of the flight.
- 9) The pilot in command of this aircraft must advise each passenger of the experimental nature of this aircraft, and explain that it does not meet the certification requirements of a standard certificated aircraft.
- 10) This aircraft must contain the placards, markings, etc. required by 91.9©.

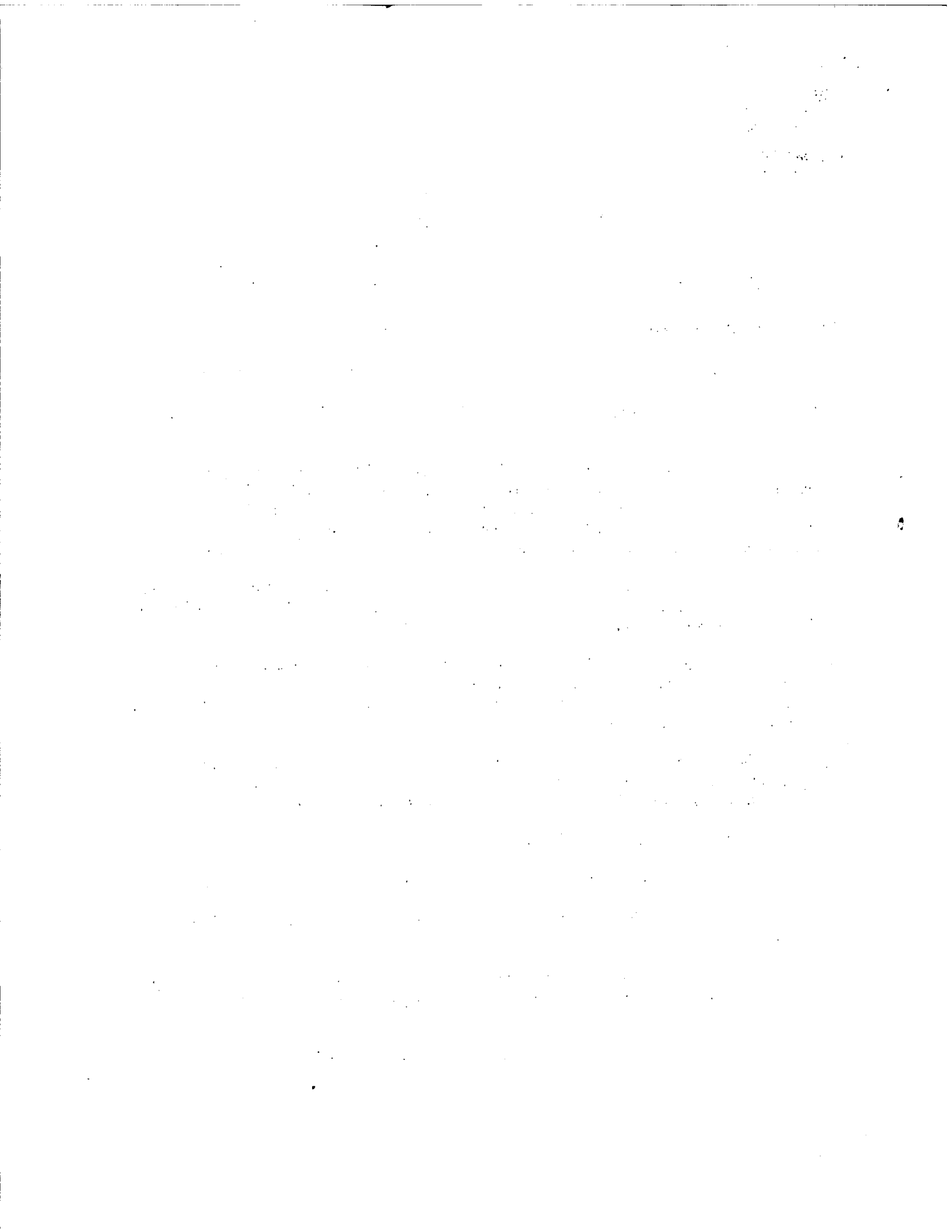

- 11) This aircraft is prohibited from aerobatic flight, that is, an intentional maneuver involving an abrupt change in the aircraft's attitude, an abnormal attitude, or abnormal acceleration not necessary for normal flight.
- 12) No person may operate this aircraft unless within the preceding 12 calendar months it has had a condition inspection performed in accordance with appendix D of part 43, or other FAA approved program, and was found to be in a condition for safe operation. This inspection will be recorded in the aircraft maintenance records.
- 13) Only FAA certificated mechanics with appropriate ratings as authorized by 43.3 may perform inspections required by these operating limitations.
- 14) Inspections must be recorded in the aircraft maintenance records showing the following, or a similar worded statement: "I certify that this aircraft has been inspected on [insert date] in accordance with the scope and detail of appendix D to part 43, or other FAA approved program, and was found to be in a condition of safe operation." The entry will include the aircraft's total time-in-service, and the name, signature, certificate held by the person performing the inspection.
- 15) This aircraft must display the word "EXPERIMENTAL" in accordance with 45.23(b).
- 16) The pilot in command of this aircraft must notify air traffic control of the experimental nature of this aircraft when operating into or out of airports with operating control towers. The pilot in command must plan routing that will avoid densely populated areas and congested airways when operating VFR.
- 17) Aircraft instruments and equipment installed and used under 91.205 must be inspected and maintained in accordance with the requirements of parts 43 and 91. Any maintenance or inspection of this equipment must be recorded in the aircraft maintenance records.
- 18) Application must be made to the Atlanta MIDO for any revision to these operating limitations.
- 19) Section 47.45 requires that the FAA Aircraft Registry must be notified within 30 days of any change in the aircraft registrant's address. Such notification is to be made by submitting Form 8050-1 to AFS-750 in Oklahoma City, Oklahoma.

Nov. 7, 2007
Date

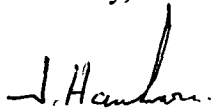

John Hankinson
FAA Representative

DARF501107CE
Designation

These operating Limitations have been explained, are understood and accepted

Nov. 7, 2007
Date

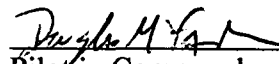

Pilot in Command

