

Keith Dann

From: Keith Dann
Sent: Wednesday, November 19, 2014 1:44 PM
To: 'Keith Dann'
Subject: Standing Strategic Planning Subcommittee Meeting

Good morning Standing Strategic Planning Subcommittee (SSPS) Members

As you know, the next SSPS meeting is scheduled for 9 AM on Tuesday, December 2, 2014, at the CHP Headquarters, 601 N. 7th Street, Sacramento, CA, 95811. Just confirming your attendance and letting you know the agenda will be forthcoming later this week.

Thanks so much and if you could please respond to this email and let me know, it would be appreciated.

Keith Dann, Assistant Bureau Chief
California Department of Justice
Bureau of Criminal Information and Analysis
Telephone: 916.227.3466
keith.dann@doj.ca.gov

California Law Enforcement Telecommunications System (CLETS)
Advisory Committee (CAC)

Standing Strategic Planning Subcommittee (SSPS)
Meeting Minutes

August 12, 2014
California Highway Patrol Headquarters, Sacramento

Present: Chair: Sam Spiegel (California Peace Officers' Association)

Julie Basco (Department of Justice)
Janelle Dickey (Department of Motor Vehicles)
Tom Bruce (California Police Chiefs' Association)
Laurie Porcari (California State Association of Counties)
Sherri Rinkel (League of California Cities)
Ashish Kakkad (California State Sheriffs' Association)
John Lemmon (California Office of Emergency Services)

Absent: Marc Shaw (California Peace Officers' Association)
Rita Lugo (California Highway Patrol)
Chris Emery (California Police Chiefs Association)

CALL TO ORDER

Chair Spiegel called the meeting to order at 9:02 a.m.

ROLL CALL

CLETS Executive Secretary Keith Dann called roll; a quorum was present.

APPROVAL OF MINUTES

A motion was made to approve the minutes from the meeting of April 30, 2014.

Motion: Julie Basco
Second: Sherri Rinkel
Vote: Approved unanimously

CHAIR'S REPORT

No report at this meeting.

CLETS STRATEGIC PLAN

SSPS member discussion of each 2009 CLETS Strategic Plan goal ensued regarding not only the progress, but whether or not the goals have current benefit to CLETS.

Goal 1

Implement mobile technology for cite-and-release (arrest) processing to increase arrests received by the Department of Justice (DOJ) by 30 percent, populate court calendars with arrest and verifying fingerprint information; complete arrest cycle and forward information to the Federal Bureau of Investigation (FBI); and allow courts to submit dispositions with fingerprints to positive link with the original arrest.

Discussion

Committee members agree to recommend to the CAC the removal of this goal from the 2009 CLETS Strategic Plan because the primary focus was the completeness of the State's criminal record repository, not CLETS.

Result

Recommendation to remove Goal 1 from the 2009 CLETS Strategic Plan was provided to the CAC. *Addendum: The CAC approved recommendation on August 12, 2014.*

Goal 2

Create an arrest and disposition interface between the DOJ and the Administrative Office of the Courts.

Discussion

Committee members agree to recommend to the CAC the removal of this goal from the 2009 CLETS Strategic Plan because the primary focus was the completeness of the State's criminal record repository, not CLETS.

Result

Recommendation to remove Goal 2 from the 2009 CLETS Strategic Plan was provided to the CAC. *Addendum: The CAC approved recommendation on August 12, 2014.*

Goal 3

Make a mobile device multi-modal for traffic citation generation and interface to traffic courts and the Department of Motor Vehicles (DMV).

Discussion

Chair Spiegel summarized previous committee discussions regarding the need to examine current technology being used for traffic citations and identify future steps necessary to incorporate fingerprints into the traffic citation process.

Result

Recommendation to reword 2009 CLETS Strategic Plan Goal 3 was provided to the CAC. *Addendum: The CAC approved recommendation on August 12, 2014.*

Action

SSPS members to reword 2009 CLETS Strategic Plan Goal 3 to include the incorporation of fingerprints into the traffic citation process.

Goal 4

Transmit "Failure to Appear" (FTA) bench warrants to DOJ and the FBI and have a fingerprint associated with the warrant for positive identification.

Discussion

Committee members discussed Goal 4, which proposes adding a fingerprint to be transmitted with the FTA. It was discussed that the SSPS may be able to address this goal with SmartJustice and a fusion between the Criminal Justice Information System (CJIS) databases and the Automated Criminal History System (ACHS). Chair Spiegel stated another way to look at Goal 4 is it expands SSPS as a user group to recommend SmartJustice enhancements.

Action

Further exploration of 2009 CLETS Strategic Plan Goal 4 is needed to determine recommendation options to be submitted to the CAC. Committee members will consider whether to integrate 2009 CLETS Strategic Plan Goal 4 with SmartJustice and a possible fusion between the CJIS databases and the ACHS.

Goal 5

Interface juvenile arrest and disposition processing with individual county juvenile courts.

Discussion

Committee members agree to recommend to the CAC the removal of this goal from the 2009 CLETS Strategic Plan because the primary focus is the completeness of the State's criminal record repository, not CLETS.

Result

Recommendation to remove 2009 CLETS Strategic Plan Goal 5 was provided to the CAC.
Addendum: The CAC approved recommendation on August 12, 2014.

Goal 6

Involve District Attorneys (DA) to close the loop on cases (disposition) upon which no charges are ultimately filed.

Discussion

Based upon the last SSPS meeting recommendation and CAC approval, Chair Spiegel notified SSPS members that on August 7, 2014, a letter requesting increased disposition reporting was mailed to the Honorable Dean D. Flippo of the California District Attorneys Association (CDAA). A copy of the letter was distributed to the members.

Result

Completed.

Goal 8

Expand Cal-Photo's capability to share photos on a national basis; and, deploy facial recognition as an investigative tool.

Discussion

Discussion ensued regarding the value of Cal-Photo as an investigative tool, the potential to receive photos from other states and ability to utilize facial recognition in the field. SSPS member Dickey indicated the DMV cannot currently meet a request to share DMV photos nationally or for use in facial recognition under current statutory and regulatory authority. SSPS member Dickey recommended that Goal 8 be removed from the 2009 CLETS Strategic Plan at this time pending further discussion between SSPS and DMV administration. However, SSPS member Kakkad and SSPS member Rinkel both expressed that this is an extremely important issue for law enforcement and should not be allowed to drop from the 2009 CLETS Strategic Plan and future considerations.

SSPS member Basco stated the NLETS (International Justice and Public Safety Network) has engaged in photo sharing with many other states and has a template in place; therefore, the technological model exists to electronically share photo information. SSPS member Basco also expressed NLETS would bring significant staff support and financial resources to assist in the implementation of a digital photo sharing system. After further discussion, it was agreed that a meeting be scheduled with the DMV Director to discuss a possible solution under current legislation and/or to propose legislative changes.

Result

Recommendation to reword 2009 CLETS Strategic Plan Goal 8, as follows, was provided to the CAC:

Representatives from the California Police Chiefs' Association, the California State Sheriffs' Association, the California Peace Officers' Association, the DOJ and the CAC or SSPS representatives will meet with the DMV Director to discuss:

- 1. Electronic, interstate exchange of drivers license and identification photos for law enforcement purposes; and,*
- 2. Facial recognition technology.*

Addendum: The CAC approved recommendation on August 12, 2014.

Action

Further discussion is needed by committee members to address 2009 CLETS Strategic Plan Goal 8 through a meeting with the aforementioned entities.

New Goal 1

Capture and share Global Positioning System (GPS) based geospatial data on offenders statewide.

Discussion

SSPS member Basco stated there is no electronic monitoring field in the Supervised Release File (SRF) at this time; however, it has been determined a field can be added to SRF into which GPS information can be added. SSPS member Basco explained that due to SRF limitations, if GPS coordinates were entered into SRF, there would be no hyperlink capability to a GPS map or a real-time locating component for investigations. Several members indicated this would still be viable with a cut and paste function to a mapping software. Member Basco also indicated this data would only be as accurate as the last data entered by the field.

Division of California Justice Information Services Director Cuong Nguyen reported on task 8 (*Determine if California probation departments are interested in entering GPS data*) from the previous meeting. Specifically, Director Nguyen expressed the field's opinion regarding the inclusion of a static GPS location into the SRF would be of very limited value. Chair Spiegel then led a discussion of what the original objective of New Goal 1 had been and whether the entry of a static GPS location would be of value to investigators attempting to identify the location of parolees at a particular point in time. SSPS member Basco suggested New Goal 1 could be joined with Goal 4 since one of the primary goals of SmartJustice is to integrate local probation information. SSPS member Basco indicated that perhaps the current data schema for SmartJustice could be expanded to include the collection of GPS data and accordingly, the committee unanimously agreed to request Goal 4 be restated to include GPS data.

Result

Recommendation to reword 2009 CLETS Strategic Plan Goal 4 to include GPS data was provided to the CAC. *Addendum: The CAC approved recommendation on August 12, 2014.*

Action

Incorporate New Goal 1 intent with 2009 CLETS Strategic Plan Goal 4, which would require further exploration by committee members regarding the inclusion of GPS data on offenders within SmartJustice.

New Goal 2

The DOJ to host a Record Management System for information sharing purposes.

Discussion

Division of California Justice Information Services Director Cuong Nguyen reported on task 9 (*Address the issue of the DOJ hosting a record management system or providing software as a service*) from the previous meeting. Specifically, Director Nguyen reported to the committee that a white paper was currently being written, which recommends the development of a records management system for law enforcement. Director Nguyen indicated that if approved by the Attorney General, the approach would be to meet with law enforcement associations to determine system requirements. Director Nguyen further explained the creation of a standardized record management system would provide the advantage of standardizing data and reducing training costs for those electing to migrate to the system.

SSPS member Bruce asked if it has been determined how many counties do not have a record management system. Director Nguyen indicated there were currently five; however, the total projected number is not known at this time. Chair Spiegel expressed many agencies with investigative units may also have an interest in a records management system which could increase the number of interested organizations.

Result

No action needed.

New Goal 3

The DOJ to provide increased outreach in the areas of reporting statistics and Agency CLETS Coordinator training

Discussion

It was agreed that training is currently available via webinars with the DOJ Client Services Program.

Result

Completed.

MEMBERS' REPORTS

SSPS member Basco notified the committee that the DOJ is blending the support and outreach functions for the DOJ's JusticeMobile and SmartJustice platforms in order to provide a more unified support structure for users. SSPS member Basco noted that the SmartJustice integration has been delayed due to extensive customization required to accommodate local data; however, the rollout of SmartJustice was moving forward and the system should be available to all large populated cities by the end of the year.

Chair Spiegel indicated that he would like for another SSPS member to consider assuming the duties of the SSPS Chair. He asked that interested persons contact him directly and that he would like to appoint a new Chair by the December meeting.

SSPS DISCUSSION/OPEN FORUM/PUBLIC COMMENT

Audience member Tam-Thao Le (DMV) reinforced comments made earlier by SSPS member Dickey concerning the limitations imposed on the DMV in releasing photographs to out-of-state agencies under current statute. SSPS member Basco indicated information would only be provided to out-of-state law enforcement agencies. Chair Spiegel then expressed that we must define access through legislation and that SSPS can assist by providing direction.

NEXT SSPS MEETING

The meeting was adjourned at 10:10 a.m. The next SSPS meeting is scheduled for December 2, 2014 at 9 a.m.

2009 CLETS Strategic Plan

Goals-Current Wording

1) ID 2

Goal #3

Make a mobile device multi-modal for traffic citation generation and interface to traffic courts and the Department of Motor Vehicles (DMV).

2) ID 3

Goal #4

Transmit "Failure to Appear" (FTA) bench warrants to DOJ and the FBI and have a fingerprint associated with the warrant for positive identification.

New Goal One

Capture and share Global Positioning System (GPS) based geospatial data on offenders statewide.

3) ID 5

Goal #8- New wording approved by CAC 08-12-2014

Representatives from the California Police Chiefs Association, the California State Sheriffs' Association, the California Police Officers' Association and the Department of Justice CLETS Advisory Committee or SSPS representatives will meet with the Department of Motor Vehicles Director to discuss:

- 1. Electronic, interstate exchange of driver license and identification photos for law enforcement purposes; and,*
- 2. Facial recognition technology.*

Department of Justice
CLETS Advisory Committee
Standing Strategic Planning Subcommittee Meeting
Agenda

California Highway Patrol
601 N. 7th Street
Sacramento, CA 95811

December 2, 2014
9:00 a.m.

1. Call to Order
2. Roll Call
3. Audience Introductions
4. VOTE: Meeting Minutes of August 12, 2014
5. 2009 CLETS Strategic Plan
6. Members' Reports
7. SSPS Discussion/Open Forum/Public Comment
8. Next SSPS Meeting/Adjourn

Standing Strategic Planning Subcommittee Tasks

In Process
 Removed



ID	Task Title/Description	Assigned To	Due Date	Priority	Status
2	Recommend rewording 2009 CLETS Strategic Plan Goal 3 to any future CLETS Strategic Plan as incorporating fingerprints into the traffic citation process so when a booking and release citation is issued, there is an associated fingerprint, which can be utilized for positive identification and for inclusion on the individual's rapsheet. (Goal 3) Presented and approved by the CAC. Task: Further discussion of rewording Goal 3 to incorporate "fingerprints" into the traffic citation process.	SSPS			✓
3	Further exploration by committee members of addressing 2009 CLETS Strategic Plan Goal 4 with SmartJustice and a fusion between the CJIS databases and the ACHS to determine recommendation options to the CAC. (Goal 4) Presented to the CAC and approved for further exploration by SSPS. Task: Further discussion of SmartJustice/CJIS Databases/ACHS is needed, but also need to incorporate New Goal 1 intent, which is to have GPS data available for offenders/registrants.	SSPS			✓
5	Determine if DMV photos can be shared nationally for investigative purposes. (Goal 8) Reworded Goal 8 presented and approved by the CAC. Task: Further discussion on LEA associations/DOJ meeting with DMV Director.	SSPS			✓
6	Determine availability of using facial recognition with Cal-Photo and California DMV photos. (Goal 8) Reworded Goal 8 presented and approved by the CAC. Task: Further discussion on LEA associations/DOJ meeting with DMV Director.	SSPS			✓

Standing Strategic Planning Subcommittee Tasks

✓ In Process
 ⊗ Removed



ID	Task Title/Description	Assigned To	Due Date	Priority	Status
7	Look at the architecture of the SRF to determine if a data field can be added that includes GPS data and a hyperlink SSPS which provides the ability to ping the location of the SRF registrant. A field can be added to SRF, which would allow GPS data to be entered; however, hyperlink capability would not be available. An alternate solution would be for the individual to cut and paste the GPS data into another application or browser. Task: Incorporate New Goal 1 intent with 2009 CLETS Strategic Plan Goal 4 (ID#2)				✓
9	Address the issue of the DOJ hosting a record management system or providing software as a service at the next CSSA and CPCA Data Sharing Committee meeting and report back to the SSPS. A white paper is being developed and once completed, DOJ will report back to the SSPS.	DOJ			✓
1	Recommend to the CAC the removal of Goals 1, 2 and 5 from 2009 CLETS Strategic Plan	DOJ			⊗
4	SSPS recommended the CAC address the issue of increased disposition reporting with the CDAA. (Goal 6) Recommendation presented to the CAC and approved. Letter sent to CDAA.	SSPS			⊗

Standing Strategic Planning Subcommittee Tasks

In Process
 Removed



ID	Task Title/Description	Assigned To	Due Date	Priority	Status
8	Determine if California probation departments are interested in entering geospatial data on offenders at the next CSAA and GPGA Data Sharing Committee meeting and report back to the SSPS.	DOJ			<input type="checkbox"/>
10	Review providing Agency GLETS Coordinator (ACC) training possibly in the format of a webinar rather than a coordinated outreach to GLETS subscribing agencies. ACC Webinar Training is currently available via the DOJ's Client Services Program. Interested agencies can email ALTSTraining@doj.ca.gov to schedule an appointment	DOJ			<input type="checkbox"/>

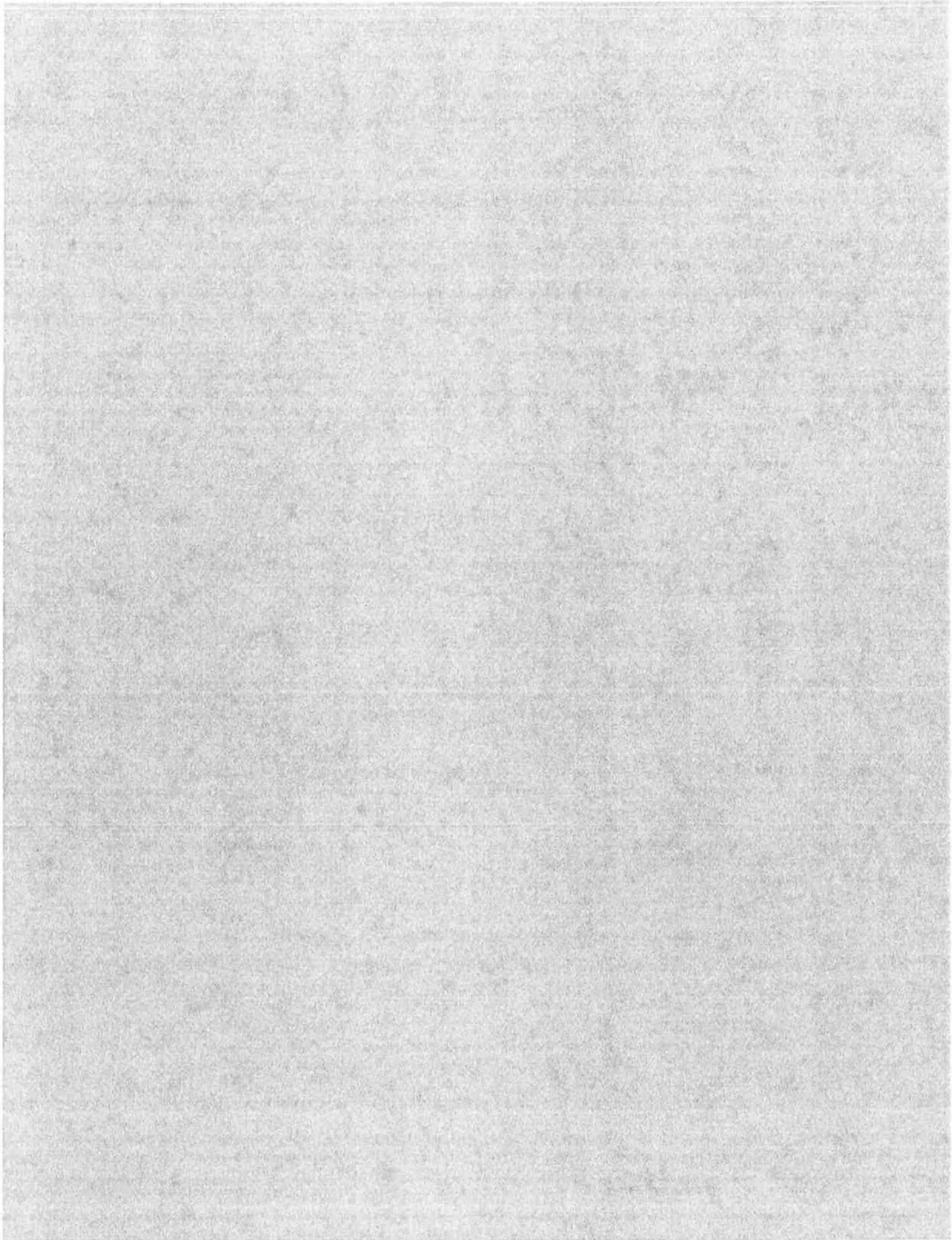



**Department of Motor Vehicles Code Citation Response
to the CLETS (Draft) Strategic Plan 2014; Goal #8**

Goal #8 Representatives from the California Police Chiefs' Association, the California State Sheriffs' Association, The California Peace Officers' Association, the DOJ and the CAC or SSPS representatives will meet with the DMV Director to discuss:

- 1. Electronic, interstate exchange of drivers' license and identification photos for law enforcement purposes; and*
- 2. Facial recognition technology*

DMV Code Citations Response to the CLETS Standing Strategic Planning Subcommittee (SSPS) request on 12/2/14

State and federal statutes and regulations address the confidentiality and release of personal information in the form of Driver License (DL) and Identification (ID) photos contained in the Department of Motor Vehicles (DMV) database.

The California Information Practices Act (IPA) (Civil Code (CC) §1798, et. seq.) imposes restrictions on the release of photos. CC §1798.1(c), states that in order to protect the privacy of individuals it is necessary that the maintenance and dissemination of personal information be subject to strict limits. CC §1798.3(a), defines personal information as any information that is maintained by an agency that identifies or describes an individual including, but not limited to his or her name, social security number, physical description, home address, home telephone number, education, financial matters, and medical or employment history. The IPA imposes a general prohibition against release of personal information; however, there are exceptions such as release to a government entity when required by state or federal law, or to a law enforcement or regulatory agency when required for an investigation of unlawful activity unless the disclosure is otherwise prohibited by law.

Vehicle Code (VC) §1810.5, authorizes law enforcement and specified government entities to access DMV records, including photos. The methods of accessing the department's records are limited by regulation.

Title 13, California Code of Regulations (CCR), Article 5, §350.10, specifies that in order to obtain information from DMV about a licensee; a government requester must provide sufficient identifying points of information including the driver's full name and date of birth or the driver's license number only (the same requirements apply to identification cards).



**Department of Motor Vehicles Code Citation Response
to the CLETS (Draft) Strategic Plan 2014; Goal #8**

VC §1808.5, establishes all records of the department relating to the physical condition of any person are confidential and not open to public inspection. This is considered applicable to a photo since it provides information relating to the physical condition of the DL/ID holder.

VC §§12800.5 and 13005.5, explicitly restrict the release of DL/ID photos. The department is prohibited, unless requested by the subject of the photo, from distributing, selling the picture or photo, or any information pertaining to the physical characteristics of the subject to any private individual or any firm, co-partnership, association or corporation. The statutes referenced in this paragraph do not directly apply to NLETS; however, provide examples of existing restrictions regarding the release of DL/ID photos.

The Federal Driver's Privacy Protection Act (DPPA) [United States Code, Title 18, §§2721-2725], prohibits generally, the disclosure of highly restricted personal information (includes photos) to any person or entity, however, there are exceptions. Photos are subject to mandatory disclosure in connection with certain federal laws pertaining to motor vehicles. In addition, the DPPA authorizes photo release in four discretionary categories.

An opinion from the California Attorney General in 1996 stated the discretionary release categories of the DPPA allow a state to authorize disclosure, however, access to the information is prohibited if the Legislature does not "affirmatively authorize" disclosure in the specified circumstances. No affirmative authorization is found in existing state statutes that would require or allow the transmission and wholesale sharing of DL/ID photos between Cal-Photo and NLETS.

All government agencies, including law enforcement requesting DMV record information must complete and submit a Government Requester Account Application (INF 1130). Each government requester is required to follow security and other requirements. In the General Security Requirements section of the form, the government requester agrees to not sell, retain, distribute, provide or transfer any record information or portion of a record acquired under the government requester account agreement, except as authorized by the department.

CCR, Title 13, Article 5, §350.42, states any use of DMV information for a purpose other than stated in the approved INF 1130 application is prohibited. Section C-9 of the INF 1130 states the agency shall not sell, retain, distribute, provide or transfer any record information or portion of the record information except as authorized by the department.

DMV executed an Inter-Agency Agreement (IAA) with DOJ to allow for access to photos in DMV files. The agreement requires DOJ to not transfer, distribute, enter into any third party agreement or otherwise provide images to any unauthorized entity or use images for any unauthorized purposes. In addition, DOJ shall not retain images for the purposes of creating a database unless specifically authorized in writing by DMV's Information Services Branch Chief.



**Department of Motor Vehicles Code Citation Response
to the CLETS (Draft) Strategic Plan 2014; Goal #8**

Currently, NLETS is authorized to obtain DL/ID photos from CLETS/Cal-Photo on a “one-in/one-out” basis for law enforcement and other government agencies authorized by statute and approved by DOJ and DMV. Authorized law enforcement and government agencies making a request for DL/ID photos through DMV, CLETS, or NLETS are required to provide identifying points of information to ensure the correct photo is provided to the requester and for tracking the release and receipt of the photo.

DMV and DOJ are required to maintain an accurate accounting of the date, nature, and purpose of each disclosure of personal information pursuant to CC §1798.25. The accounting is required to include the name, title, and business address of the person or agency to which the disclosure was made. Routine disclosures of information pertaining to crimes, offenders, and suspected offenders to law enforcement or regulatory agencies of federal, state, and local government are considered disclosures pursuant to CC §1798.24(e) for the purpose of meeting these requirements.

Accordingly, DMV in meeting its obligations to maintain an accurate accounting of each disclosure of personal information has the authority to audit DOJ for the purpose of determining compliance with statute, regulations, and other requirements contained in the IAA.

Conversely, the transmission and wholesale sharing of DL/ID photos between Cal-Photo and NLETS raises significant concerns. DMV has a statutory and regulatory obligation to protect all information, including photos that are maintained in the department’s database. There is no viable method for DMV to account for each disclosure of California DL/ID photos via NLETS under this proposal. The proposed expansion of photo-sharing between CLETS/Cal-Photo and NLETS may open the door to random accessing of photos without providing identifying points of information. The inability to account for each California DL/ID photo disclosure via NLETS would make it difficult, if not impossible to track the source of a security breach involving the NLETS network.

At this time, DMV cannot support Goal #8 to the extent it depends on the use of any California DMV information, specifically DL/ID photos. Existing statute and regulations require a vast array of security measures to protect DMV record information for the reasons stated.

References

California Vehicle Code, §§1808.5, 1810.5, 12800.5, and 13005.5

<http://www.dmv.ca.gov/portal/dmv/detail/pubs/vctop/vc/d2/c1/a3/1808.5>

<http://www.dmv.ca.gov/portal/dmv/detail/pubs/vctop/vc/d2/c1/a3/1810.5>

<http://www.dmv.ca.gov/portal/dmv/detail/pubs/vctop/vc/d6/c1/a3/12800.5>

<http://www.dmv.ca.gov/portal/dmv/detail/pubs/vctop/vc/d6/c1/a5/13005.5>



**Department of Motor Vehicles Code Citation Response
to the CLETS (Draft) Strategic Plan 2014; Goal #8**

References, *continued*

***Information Practices Act (California Civil Code) §§1798, 1798.1(c), 1798.3(a), 1798.24,
and 1798.25***

[http://leginfo.legislature.ca.gov/faces/codes_displaySection.xhtml?lawCode=CIV§ionNum=1798.](http://leginfo.legislature.ca.gov/faces/codes_displaySection.xhtml?lawCode=CIV§ionNum=1798)

[http://leginfo.legislature.ca.gov/faces/codes_displaySection.xhtml?lawCode=CIV§ionNum=1798.1.](http://leginfo.legislature.ca.gov/faces/codes_displaySection.xhtml?lawCode=CIV§ionNum=1798.1)

[http://leginfo.legislature.ca.gov/faces/codes_displaySection.xhtml?lawCode=CIV§ionNum=1798.3.](http://leginfo.legislature.ca.gov/faces/codes_displaySection.xhtml?lawCode=CIV§ionNum=1798.3)

[http://leginfo.legislature.ca.gov/faces/codes_displaySection.xhtml?lawCode=CIV§ionNum=1798.24.](http://leginfo.legislature.ca.gov/faces/codes_displaySection.xhtml?lawCode=CIV§ionNum=1798.24)

[http://leginfo.legislature.ca.gov/faces/codes_displaySection.xhtml?lawCode=CIV§ionNum=1798.25.](http://leginfo.legislature.ca.gov/faces/codes_displaySection.xhtml?lawCode=CIV§ionNum=1798.25)

California Code of Regulations, Title 13, Article 5, §§350.10, and 350.42

Section 350.10

[https://govt.westlaw.com/calregs/Document/I9DF7BEC0D46811DE8879F88E8B0DAAAE?viewType=FullText&originationContext=documenttoc&transitionType=CategoryPageItem&contextData=\(sc.Default\)](https://govt.westlaw.com/calregs/Document/I9DF7BEC0D46811DE8879F88E8B0DAAAE?viewType=FullText&originationContext=documenttoc&transitionType=CategoryPageItem&contextData=(sc.Default))

Section 350.42

[https://govt.westlaw.com/calregs/Document/IA1BD7950D46811DE8879F88E8B0DAAAE?viewType=FullText&originationContext=documenttoc&transitionType=CategoryPageItem&contextData=\(sc.Default\)](https://govt.westlaw.com/calregs/Document/IA1BD7950D46811DE8879F88E8B0DAAAE?viewType=FullText&originationContext=documenttoc&transitionType=CategoryPageItem&contextData=(sc.Default))

Federal Driver's Privacy Protection Act, U.S. Code, Title 18, §§2721-2725

[http://uscode.house.gov/view.xhtml?req=\(title:18 section:2721 edition:prelim\) OR \(granuleid:USC-prelim-title18-section2721\)&f=treesort&edition=prelim&num=0&jumpTo=true](http://uscode.house.gov/view.xhtml?req=(title:18 section:2721 edition:prelim) OR (granuleid:USC-prelim-title18-section2721)&f=treesort&edition=prelim&num=0&jumpTo=true)

Attorney General Opinion: 79 Ops.Cal.Atty.Gen. 76 (June 10, 1996)

<http://oag.ca.gov/system/files/opinions/pdfs/95-805.pdf?>

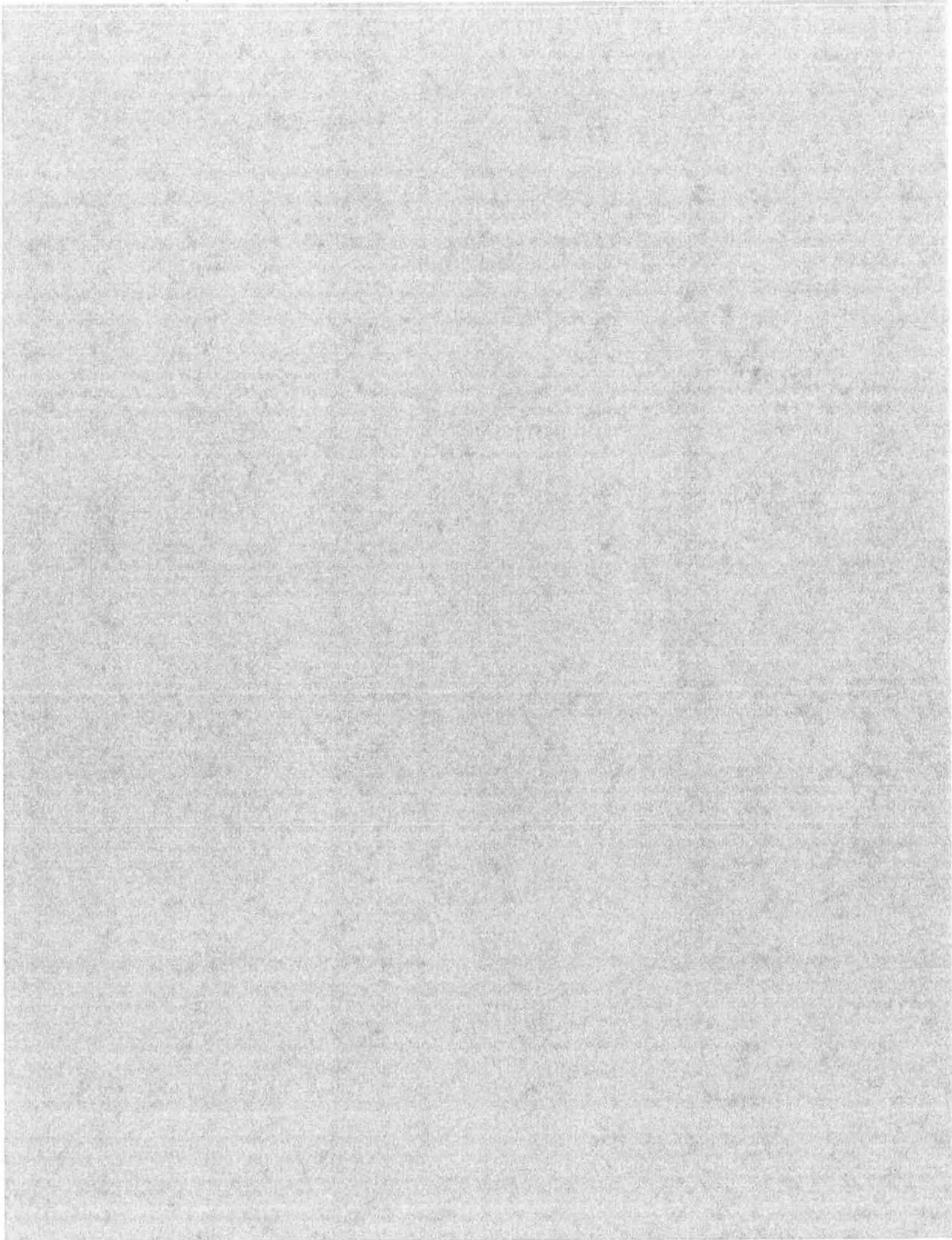

California Law Enforcement Telecommunications System (CLETS)
Advisory Committee (CAC)

Standing Strategic Planning Subcommittee (SSPS)
Meeting Minutes

December 2, 2014

California Highway Patrol, Sacramento

Present: Chair: Tom Bruce (California Police Chiefs' Association Technology Committee)

Members: Julie Basco (Department of Justice)
Sam Spiegel (California Peace Officers' Association)
Janelle Dickey (Department of Motor Vehicles)
Sherri Rinkel (League of California Cities)
Chris Emery (California Police Chiefs' Association)
John Lemmon (Office of Emergency Services)

Absent: Marc Shaw (California Peace Officers' Association)
Laurie Porcari (California State Association of Counties)
Rita Lugo (California Highway Patrol)
Ashish Kakkad (California State Sheriffs' Association)

CALL TO ORDER

Chair Bruce called the meeting to order at 9:16 AM.

ROLL CALL

CLETS Executive Secretary, Keith Dann, called the roll; a quorum was present.

CHAIR'S REPORT

Member Spiegel announced that he had been contacted by several persons interested in assuming the position of SSPS Chair and that he has selected member Tom Bruce to become the new SSPS Chair.

APPROVAL OF MINUTES

A motion was made to approve the minutes from the meeting of August 12, 2014.

Motion: Julie Basco
Second: Janelle Dickey
Vote: Approved unanimously

CLETS STRATEGIC PLAN

With the approval of the CAC at the August 12, 2014 meeting, the SSPS members engaged in a discussion of the restatement of 2009 CLETS Strategic Plan goals

Goal 3

Make a mobile device multi-modal for traffic citation generation and interface to traffic courts and the Department of Motor Vehicles (DMV).

Discussion

Committee members engaged in a discussion of Goal 3 and how it should be restated to include “fingerprints” in the traffic citation process. Chair Bruce began the discussion by stating that due to the passage of Proposition 47, the need for an in-the-field, cite and release system had increased to include misdemeanors, as well as traffic infractions.

Member Basco noted that as currently stated, Goal 3, specifies “traffic citation” events and that the Department of Justice (DOJ) does not record traffic infractions. After further discussion of the processes used by law enforcement agencies (LEA) to document infraction and misdemeanor events in the field, it was determined that Goal 3 could be framed to include changes created by Proposition 47 by including misdemeanor events.

The members then discussed possible scenarios of the transmission of data collected in the field. Member Basco explained that thumbprints and partial prints would not be accepted by the Federal Bureau of Investigation (FBI) and that the original vision of this goal was for the DOJ to assist the courts and not to enter field traffic infractions onto an individual’s criminal offender record information (CORI). Member Dickey then asked for clarification on how LEAs envision a field “cite and release” system would interact with the Department of Motor Vehicles (DMV) and the courts.

A discussion followed which illustrated the differences between citations, infractions, and misdemeanor events. It was then agreed that when restated, Goal 3, should clarify the group’s intention to include infractions, as well as misdemeanors. Member Basco then asked members if their vision of a system under Goal 3 included the adding of misdemeanor events, captured in the field, to an individual’s CORI with traffic infractions being sent to the DMV.

Chair Bruce indicated that his original thought was for the thumbprint to be used as a means of identification without forwarding them to DOJ, however, he believed an entry on an individual’s CORI identified as “thumbprint only,” would have value. Member Spiegel expressed the idea that having a thumbprint record on file would be a valuable audit tool to track people who failed to appear for booking and further expressed that Goal 3’s intent should entail Vehicle Code violations being sent to the DMV with other misdemeanors being sent to the DOJ.

The remaining discussion involved the rewording of Goal 3.

Result:

Recommend rewording 2009 CLETS Strategic Plan Goal 3, as follows, to the CAC:

To enable biometric capture of misdemeanor and infraction information for transmission to the appropriate agency’s repository and will work with current technology.

Goal 4

Transmit "Failure to Appear" (FTA) bench warrants to DOJ and the FBI and have a fingerprint associated with the warrant for positive identification.

Discussion

Member Basco began the discussion by asking for clarification on how a fingerprint would be transmitted to the court to be matched to the warrant under this goal. Member Spiegel indicated that with the completion of Goal 3, fingerprints would already be in the system and available to match to the warrant. A discussion followed on the relationship between Goal 3 and Goal 4 and it was determined that Goal 4 was dependent on the completion of Goal 3.

Member Basco informed the group that the DOJ's current Wanted Persons System (WPS) does not accommodate biometrics and that an update or new system would be required to store information containing biometrics. She also informed members that the FBI does not accept biometrics from the WPS. Member Spiegel then expressed that with the passage of Proposition 47, there would be an increasing number of FTAs going forward and that biometrics for FTA bench warrants would become increasingly important. After further discussion, it was determined that a first step should be to focus on the biometric field citation process as outlined in Goal 3.

It was then discussed that the probable routing of the field citation would most likely be from the LEA to the courts and then, if there was a "FTA," the court would forward the FTA bench warrant, along with the biometric, to be entered into the DOJ's WPS. Member Rinkel voiced agreement with this process and asked whether SmartJustice was capable of biometrics. Member Basco responded that SmartJustice does not accommodate biometrics and is primarily a front end portal used to access existing DOJ systems and county specific data.

Chair Bruce then summarized the discussion by confirming that Goal 4 was dependent on the completion of Goal 3. The envisioned process would involve the captured print being transmitted from the LEA to the courts and upon a "FTA," the court would transmit the bench warrant, along with the biometric, to the DOJ; understanding that a fingerprint or thumbprint could not be forwarded to the FBI. Accordingly, all members expressed agreement with an earlier suggestion by Member Emery, to make Goal 4 a subset of Goal 3.

The remaining discussion involved the rewording of Goal 4 to become a subset of Goal 3.

Result:

Recommend rewording 2009 CLETS Strategic Plan Goal 4, as follows, to the CAC:

To become Goal 3.1

Transmit "Failure to Appear" (FTA) bench warrants to the DOJ with a fingerprint or thumbprint.

New Goal 1

Capture and share Global Positioning System (GPS) based geospatial data on offenders statewide.

Discussion

Chair Bruce summarized the August 12th, 2014 discussion leading to the rewording of New Goal 1, which was subsequently approved by the CAC. California Justice Information Services (CJIS) Director Nguyen, then restated for the members that current DOJ technology, including SmartJustice, does not allow for the capture of historical or live GPS locations. Member Spiegel then informed the members that the Office of Emergency Services (OES) has been looking at software which would have the capability of tracking live events and that perhaps the SSPS should contact OES to determine the status of their work and its possible use in New Goal 1.

After additional discussion, Member Spiegel noted that real-time information has great value to an investigator in some situations and may be more valuable than historical information. Member Basco then noted that the original objective of New Goal 1 was to have GPS real-time information available in the Supervised Release File (SRF) to determine location. She further indicated that in a review of the current SRF system, that a GPS fixed location could be entered into the SRF system, however, real-time locating and historical movement tracking was not possible. It was then determined by the group, that the rewording of New Goal 1 should be broad enough to allow for the exploration of both historical and real-time monitoring systems, as well as, a variety of existing systems.

The remaining discussion involved the rewording of New Goal 1.

Action:

Recommend rewording 2009 CLETS Strategic Plan New Goal 1, as follows, to the CAC:

Explore the capture and sharing of historical and real-time Global Positioning System (GPS) based geospatial data on offenders statewide.

Goal 8

Expand Cal-Photo's capability to share photos on a national basis; and, deploy facial recognition as an investigative tool.

Discussion:

Member Dickey reported that CAC Member Chief Alvarez, herself and several other DMV representatives met with the DMV Director, on September 26th, 2014 to discuss this goal and the possible legislative changes that would be needed to meet this goal. She further indicated that the meeting was an informative meeting, not a decision making meeting.

Member Dickey then provided several Government Code citations, which would need to be reviewed and possibly amended to accomplish Goal 8. Chair Bruce asked if Member Dickey would forward copies of the documents to the members and she indicated that she would. Member Spiegel proposed that a meeting with the DMV Director remain the priority to accomplish this goal. He further stated that there were currently no procedures in place to accomplish Goal 8, but he believed a review of the statutes would indicate that access for law enforcement purposes would probably be appropriate.

CJIS Director Nguyen then suggested that prior to a meeting with the DMV Director; there should be a determination of exactly what information would be requested by law enforcement. This would allow for the group meeting with the DMV Director to be as specific as possible about the information being requested. Member Basco offered that the DOJ could prepare a mock-up of the current International Justice and Public Safety Network (Nlets) response as well as a mock-up of the proposed response.

Member Dickey then indicated that there would likely be more regulatory changes necessary with the facial recognition portion of Goal 8 than the photo request portion and asked the members if they wanted to separate them into two separate meetings with the DMV Director. Members agreed that they be left together for the first meeting, due to availability issues, after which, they could be separated if necessary. The discussion then turned to who should reach out to the LEAs to request the appointment of a representative to attend the meeting with the DMV Director. The discussion concluded with the decision that the CAC Chair would send a letter to the LEAs notifying them of what the CAC is trying to accomplish with Goal 8 and requesting a representative be designated to attend the DMV meeting.

Action:

CAC Chair Spiegel to send a letter to the LEA presidents stating:

1. What the CAC is attempting to accomplish with Goal 8, and;
2. Asking them to appoint a representative to attend the meeting with the DMV Director.

Member Dickey to provide pertinent Government Code citations to members;
DOJ to prepare a mock-up of the current/proposed Nlets response.

MEMBERS' REPORTS

Member Basco informed the Members that Nlets has year-end funding available and is open to the idea of assisting California in accessing photos from other states. This would be a one direction system and indicated that the DOJ is exploring the opportunity to see if this could be accomplished without degradation to existing systems. Member Rinkel indicated that this would be of benefit to law enforcement and could not see a reason to turn this offer away. Member Basco then stated that accepting this offer could allow for the creation of an infrastructure to possibly pave the way for California to share photos with other states, if it is approved later.

Member Spiegel reported the California Police Chiefs' Association (CPCA) is seeking chiefs or seconds-in-command, as gubernatorial appointments, to represent the CPCA on the 911 Advisory Board. Applicants should contact CPCA President Christopher Boyd.

Chair Bruce thanked CJIS Director Nguyen for his service on the SSPS and congratulated him on his upcoming retirement.

SSPS DISCUSSION/OPEN FORUM/PUBLIC COMMENT

Member Rinkel indicated that she is seeking information on the various levels of CLETS training required for each level of employee. In a recent California CLETS Users Group conference, a DOJ representative indicated that individuals, with access to the building, are required to take additional security tests. She asked if there is a document outlining which tests, individuals of various levels of access, are required to take. Member Rinkel further indicated that she was especially interested in receiving information specific to vendors and volunteers. Member Basco indicated that she was unfamiliar with what was presented at the conference; however, she would check on the DOJ requirements and report back to the SSPS.

NEXT SSPS MEETING

The meeting was adjourned at 11:50 a.m. The next SSPS meeting will be scheduled for March 2015.

ACTION ITEMS

1. CAC Chair Spiegel to send a letter to the law enforcement Association presidents;
2. Member Dickey to provide pertinent Government codes and statutes to SSPS Members;
3. DOJ to prepare a mock-up of the current/proposed Nlets response;
4. DOJ to determine CLETS testing requirements for law enforcement agency personnel.

Standing Strategic Planning Subcommittee Tasks

In Process
 Removed



ID	Task Title/Description	Assigned To	Due Date	Priority	Status
2	Recommend rewording 2009 CLETS Strategic Plan Goal 3 to any future CLETS Strategic Plan as incorporating fingerprints into the traffic citation process so when a booking and release citation is issued, there is an associated fingerprint, which can be utilized for positive identification and for inclusion on the individual's rapsheet. (Goal 3) Presented and approved by the CAC to read: To enable biometric capture of misdemeanor and infraction information for transmission to the appropriate agency's repository and will work with current technology.	SSPS			✓
3	Further exploration by committee members of addressing 2009 CLETS Strategic Plan Goal 4 with SmartJustice and a fusion between the CJIS databases and the Automated Criminal History System to determine recommendation options to the CAC. (Goal 4) Presented and approved by the CAC to read: Transmit "Failure to Appear" (FTA) bench warrants to the DOJ with a fingerprint or thumbprint." Also, Goal 4 renumbered to Goal 3.1.	SSPS			✓
5	Determine if California DMV photos can be shared nationally for investigative purposes. (Goal 8) Reworded Goal 8 presented and approved by the CAC. Task: Further discussion on LEA associations meeting with DMV mangagement. CAC Chair Spiegel to send a letter to the law enforcement association presidents stating: 1. What the CAC is attempting to accomplish with Goal 8, and; 2. Asking them to appoint a representative to attend the meeting with the DMV Director. Member Dickey to provide pertinent Government codes and statutes to Member; DOJ to prepare a mock-up of the current/proposed Nlets response.	SSPS			✓

Standing Strategic Planning Subcommittee Tasks

✓ In Process
 ⊘ Removed



ID	Task Title/Description	Assigned To	Due Date	Priority	Status
6	<p>Determine availability of using facial recognition with Cal-Photo and California DMV photos. (Goal 8) Reworded Goal 8 presented and approved by the CAC. Task: Further discussion on LEA associations meeting with DMV management. CAC Chair Spiegel to send a letter to the law enforcement association presidents stating:</p> <p>1. What the CAC is attempting to accomplish with Goal 8, and; 2. Asking them to appoint a representative to attend the meeting with the DMV Director.</p> <p>Member Dickey to provide pertinent Government codes and statutes to Member; DOJ to prepare a mock-up of the current/proposed Nlets response.</p>	SSPS			✓
7	<p>Look at the architecture of the SRF to determine if a data field can be added that includes GPS data and a hyperlink which provides the ability to ping the location of the SRF registrant. <i>A field can be added to SRF, which would allow GPS data to be entered; however, hyperlink capability would not be available. An alternate solution would be for the individual to cut and paste the GPS data into another application or browser.</i> Task: To keep New Goal 1 in any future CLETS Strategic Plan. Accordingly, presented and approved by the CAC to read: Explore the capture and sharing of historical and real-time Global Positioning System (GPS) based geospatial data on offenders statewide.</p>	SSPS			✓

NLETS Driver History Inquiry

DRIVER HISTORY INQUIRY INCLUDES:

NAME
RESIDENCE ADDRESS
COUNTRY
DATE OF BIRTH
HEIGHT
EYE COLOR
HAIR COLOR
GENDER
RACE

PLUS THE FOLLOWING:



ACCIDENTS NOTED ON THIS DOCUMENT SHALL NOT BE CONSIDERED DETERMINATIVE OF FAULT OR NEGLIGENCE ON THE PART OF THE INDIVIDUAL

**

CERTIFIED A TRUE COPY OF THE D/L RECORD OF THE PERSON NAMED HEREIN AS APPEARS ON THE AUTOMATED SYSTEM OF DMV. G.S.20-26(B):

***** DRIVER LICENSE DETAILS *****

DRIVER AUTHORIZATION ID:
JURISDICTION AUTHORITY CODE: NC
ISSUE DATE: 2002-03-06
EXPIRATION DATE: 2008-04-13
DRIVING RESTRICTION CODE: NOT ELIG FOR SCHOOL BUS
DRIVER CERTIFICATION
DRIVING RESTRICTION CODE: 1
DRIVER LICENSE PERMIT QUANTITY: 0
DRIVER LICENSE COMMERCIAL CLASS CODE: B
LICENSED COMMERCIAL DRIVER: YES
DRIVER LICENSE COMMERCIAL STATUS: EXPIRED

***** DRIVER CONVICTION *****

CONVICTION DATE: 2008-11-03
CITATION DATE: 2008-11-03
DRIVER CONVICTION TEXT: CONV: (313)SPEEDING (84 MPH IN A 70)

***** DRIVING INCIDENT *****

DATE: 2014-08-29
DRIVER ACCIDENT SEVERITY: ACDNT: JOHNSTON COUNTY, NC PERS INJ

***** ADDITIONAL INFORMATION *****

FIELD NAME: MedicalCertificationStatus
FIELD VALUE: MED CERTIFICATION STATUS : UNDETERMINED

ACCIDENTS NOTED ON THIS DOCUMENT SHALL NOT BE CONSIDERED DETERMINATIVE OF FAULT OR NEGLIGENCE ON THE PART OF THE INDIVIDUAL

**

CERTIFIED A TRUE COPY OF THE D/L RECORD OF THE PERSON NAMED HEREIN AS APPEARS ON THE AUTOMATED SYSTEM OF DMV. G.S.20-26(B):

***** DRIVER LICENSE DETAILS *****

DRIVER AUTHORIZATION ID:
JURISDICTION AUTHORITY CODE: NC
ISSUE DATE: 2002-03-06
EXPIRATION DATE: 2008-04-13
DRIVING RESTRICTION CODE: NOT ELIG FOR SCHOOL BUS
DRIVER CERTIFICATION
DRIVING RESTRICTION CODE: 1
DRIVER LICENSE PERMIT QUANTITY: 0
DRIVER LICENSE COMMERCIAL CLASS CODE: B
LICENSED COMMERCIAL DRIVER: YES
DRIVER LICENSE COMMERCIAL STATUS: EXPIRED

***** DRIVER CONVICTION *****

CONVICTION DATE: 2008-11-03
CITATION DATE: 2008-11-03
DRIVER CONVICTION TEXT: CONV: (313)SPEEDING (84 MPH IN A 70)

***** DRIVING INCIDENT *****

DATE: 2014-08-29
DRIVER ACCIDENT SEVERITY: ACDNT: JOHNSTON COUNTY, NC PERS INJ

***** ADDITIONAL INFORMATION *****

FIELD NAME: MedicalCertificationStatus
FIELD VALUE: MED CERTIFICATION STATUS : UNDETERMINED

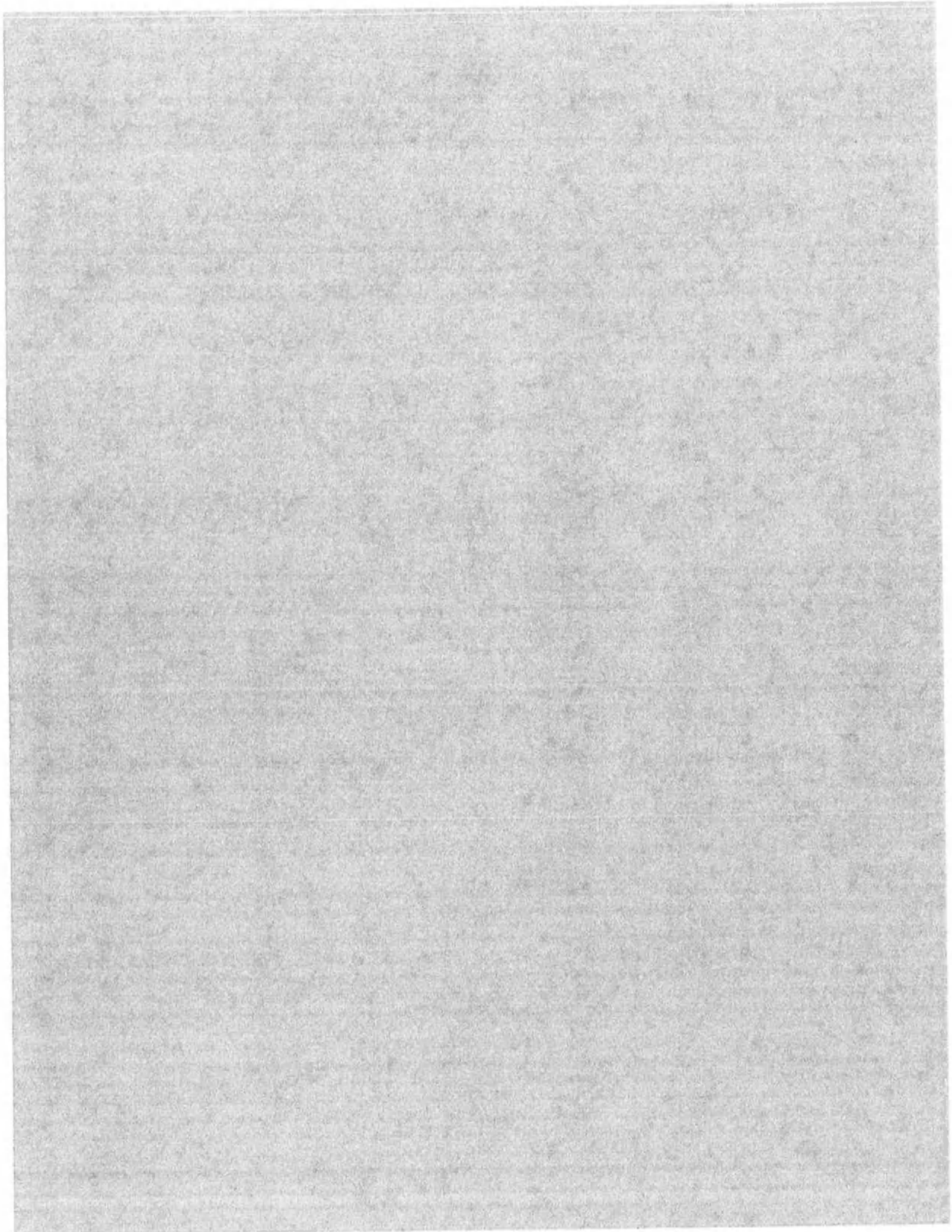

Keith Dann

From: Keith Dann
Sent: Thursday, December 04, 2014 3:57 PM
To: Adam Christianson
Cc: Carmen Green (CGreen@calsheriffs.org); Sam Spiegel
Subject: CLETS Advisory Committee - CSSA - DMV Meeting
Attachments: DMV CSSA 1242014.pdf

Good afternoon Sheriff Christianson

On behalf of the CLETS Advisory Committee (CAC) and CAC Chair Sam Spiegel, please find attached a request seeking your participation or a California State Sheriffs' Association (CSSA) representative for a meeting with the Director of the Department of Motor Vehicles.

Attached you will find full details. Hard copy to follow by mail.

Thank you,

Keith Dann, CLETS Executive Secretary
Assistant Bureau Chief
California Department of Justice
Bureau of Criminal Information and Analysis
Telephone: 916.227.3466
keith.dann@doj.ca.gov

KAMALA D. HARRIS
Attorney General

State of California
DEPARTMENT OF JUSTICE



December 4, 2014

**CLETS
ADVISORY
COMMITTEE**

Sam Spiegel
CA Peace Officers'
Association
Chair

Cuong Nguyen
Department of Justice

Evert Palmer
League of California Cities

Karen Wong
Office of Emergency
Services

Scott Howland
California Highway Patrol

Scott Marshall
CA State Sheriffs'
Association

Larry Spikes
CA State Association of
Counties

Cynthia Renaud
CA Police Chiefs Association

Frank Alvarez
Department of Motor
Vehicles

Marc Shaw
CA Peace Officers'
Association

Stanislaus County Sheriff Adam E. Christianson
California State Sheriffs' Association President
1231 I Street, Suite 200
Sacramento, CA 95814

RE: California State Sheriffs' Association (CSSA) Representative

Dear Sheriff Christianson: *Adam*

The CLETS Advisory Committee (CAC) is arranging a meeting with the Director of DMV to discuss issues pertinent to the automated sharing of DMV photos for law enforcement field use. I am seeking your participation or a representative for this meeting.

In anticipation of that meeting, once we have your designee, a meeting or conference call will be held to further identify the details of this request categorized below:

1. Electronic, interstate exchange of driver license and identification photos for law enforcement purposes via NLETS; and,
2. Facial recognition technology.

As a matter of history, the sharing of DMV photos has been a goal of the CAC for years. We now have an indication that the current administration is interested in our request, but desires more information and to better understand the importance of the request. To that end, our endeavor is to have CSSA, CPCA and CPOA represented in the meeting, preferably at the executive board level. We want to be able to punctuate the importance of the request from all three associations.

Please let me know, via email listed below, who the designated CSSA representative will be.

As always, please don't hesitate to contact me via cell if you have any questions or concerns. Thank you in advance for your support.

Sincerely,

Sam Spiegel, Chair-CLETS Advisory Committee
EMAIL: sam.spiegel@doj.ca.gov

For KAMALA D. HARRIS
Attorney General

Keith Dann

From: Keith Dann
Sent: Thursday, December 04, 2014 4:02 PM
To: 'myokoyama@alhambrapd.org'
Cc: Sam Spiegel
Subject: CLETS Advisory Committee - CPOA - DMV Meeting
Attachments: DMV CPOA 1242014.pdf

Good afternoon Chief Yokoyama

On behalf of the CLETS Advisory Committee (CAC) and CAC Chair Sam Spiegel, please find attached a request seeking your participation or a California Peace Officers' Association (CPOA) representative for a meeting with the Director of the Department of Motor Vehicles.

Attached you will find full details. Hard copy to follow by mail.

Thank you,

Keith Dann, CLETS Executive Secretary
Assistant Bureau Chief
California Department of Justice
Bureau of Criminal Information and Analysis
Telephone: 916.227.3466
keith.dann@doj.ca.gov

Keith Dann

From: Keith Dann
Sent: Thursday, December 04, 2014 4:07 PM
To: 'cboyd@citrusheights.net'
Cc: Sam Spiegel
Subject: CLETS Advisory Committee - CPCA - DMV Meeting
Attachments: DMV CPCA 1242014.pdf

Good afternoon Chief Boyd

On behalf of the CLETS Advisory Committee (CAC) and CAC Chair Sam Spiegel, please find attached a request seeking your participation or a California Police Chiefs' Association (CPCA) representative for a meeting with the Director of the Department of Motor Vehicles.

Attached you will find full details. Hard copy to follow by mail.

Thank you,

Keith Dann, Assistant Bureau Chief
California Department of Justice
Bureau of Criminal Information and Analysis
Telephone: 916.227.3466
keith.dann@doj.ca.gov

On behalf of the CLETS Advisory Committee (CAC) and CAC Chair Sam Spiegel, please find attached a request seeking your participation or a California Peace Officers' Association (CPOA) representative for a meeting with the Director of the Department of Motor Vehicles.

Attached you will find full details. Hard copy to follow by mail.

Thank you,

Keith Dann, CLETS Executive Secretary
Assistant Bureau Chief
California Department of Justice
Bureau of Criminal Information and Analysis
Telephone: 916.227.3466
keith.dann@doj.ca.gov

CONFIDENTIALITY NOTICE: This communication with its contents may contain confidential and/or legally privileged information. It is solely for the use of the intended recipient(s). Unauthorized interception, review, use or disclosure is prohibited and may violate applicable laws including the Electronic Communications Privacy Act. If you are not the intended recipient, please contact the sender and destroy all copies of the communication.

<DMV CPOA 1242014.pdf>

KAMALA D. HARRIS
Attorney General

State of California
DEPARTMENT OF JUSTICE



December 4, 2014

**CLETS
ADVISORY
COMMITTEE**

Sam Spiegel
CA Peace Officers'
Association
Chair

Cuong Nguyen
Department of Justice

Evert Palmer
League of California Cities

Karen Wong
Office of Emergency
Services

Scott Howland
California Highway Patrol

Scott Marshall
CA State Sheriffs'
Association

Larry Spikes
CA State Association of
Counties

Cynthia Renaud
CA Police Chiefs Association

Frank Alvarez
Department of Motor
Vehicles

Marc Shaw
CA Peace Officers'
Association

Alhambra Police Department Chief Mark Yokoyama
California Peace Officers' Association President
555 Capitol Mall, Suite 1495
Sacramento, CA 95814

RE: California Peace Officers' Association (CPOA) Representative

Dear Chief Yokoyama:

The CLETS Advisory Committee (CAC) is arranging a meeting with the Director of DMV to discuss issues pertinent to the automated sharing of DMV photos for law enforcement field use. I am seeking your participation or a representative for this meeting.

In anticipation of that meeting, once we have your designee, a meeting or conference call will be held to further identify the details of this request categorized below:

1. Electronic, interstate exchange of driver license and identification photos for law enforcement purposes via NLETS; and,
2. Facial recognition technology.

As a matter of history, the sharing of DMV photos has been a goal of the CAC for years. We now have an indication that the current administration is interested in our request, but desires more information and to better understand the importance of the request. To that end, our endeavor is to have CSSA, CPCA and CPOA represented in the meeting, preferably at the executive board level. We want to be able to punctuate the importance of the request from all three associations.

Please let me know, via email listed below, who the designated CPOA representative will be.

As always, please don't hesitate to contact me via cell if you have any questions or concerns. Thank you in advance for your support.

Sincerely,

Sam Spiegel, Chair-CLETS Advisory Committee
EMAIL: sam.spiegel@doj.ca.gov

For KAMALA D. HARRIS
Attorney General

Keith Dann

From: Keith Dann
Sent: Friday, December 05, 2014 9:16 AM
To: 'Yokoyama, Mark'
Cc: Sam Spiegel
Subject: RE: CLETS Advisory Committee - CPOA - DMV Meeting

Hi Mark

Thanks very much and will definitely be in touch regarding the meeting. We are looking at some time mid-February in order to allow the DMV to handle the implementation of Assembly Bill 60.

Keith Dann, CLETS Executive Secretary
Assistant Bureau Chief
California Department of Justice
Bureau of Criminal Information and Analysis
Telephone: 916.227.3466
keith.dann@doj.ca.gov

From: Yokoyama, Mark [<mailto:myokoyama@alhambrapd.org>]
Sent: Friday, December 05, 2014 9:05 AM
To: Keith Dann
Cc: Sam Spiegel
Subject: Re: CLETS Advisory Committee - CPOA - DMV Meeting

Hello Keith,

We appreciate the opportunity to be a part of this important topic. I have appointed CHP Assistant Chief and CPOA Board Member Marc Shaw to be our representative and we have already spoken about it. Marc's email is mrshaw@chp.ca.gov. I'd appreciate it if you can let me know as well the meeting will be as I will also try to attend with Marc if possible.

Thank you.

Mark

Mark Yokoyama
Chief of Police
Alhambra Police Department
[211 S. First Street Alhambra, CA 91801](http://211.S.FirstStreetAlhambra.CA.91801)
Phone [626.570.5131](tel:626.570.5131) Fax [626.576.8693](tel:626.576.8693)
Email myokoyama@alhambrapd.org

Connect with Us: [Website](#) | [Facebook](#) | [Nixle](#)

On Dec 4, 2014, at 4:04 PM, Keith Dann <Keith.Dann@doj.ca.gov> wrote:

Good afternoon Chief Yokoyama

Keith Dann

From: Keith Dann
Sent: Friday, December 05, 2014 10:48 AM
To: 'Adam Christianson'
Cc: Amy Reid; Carmen Green (CGreen@calsheriffs.org); Sam Spiegel
Subject: RE: CLETS Advisory Committee - CSSA - DMV Meeting

Thanks Sheriff Christianson

Will definitely be in touch regarding the meeting. We are looking at some time mid-February in order to allow the DMV to handle the implementation of Assembly Bill 60.

Keith Dann, CLETS Executive Secretary
Assistant Bureau Chief
California Department of Justice
Bureau of Criminal Information and Analysis
Telephone: 916.227.3466
keith.dann@doj.ca.gov

From: Adam Christianson [<mailto:chradam@stanislaussheriff.com>]
Sent: Friday, December 05, 2014 8:40 AM
To: Keith Dann
Cc: Amy Reid; Carmen Green (CGreen@calsheriffs.org); Sam Spiegel
Subject: Re: CLETS Advisory Committee - CSSA - DMV Meeting

Thank you Keith!

Let us know of the date/time/location for the meeting and we'll have someone from CSSA attend.

Adam Christianson, Sheriff-Coroner
President, California State Sheriffs' Association
Stanislaus County Sheriff's Department
250 E. Hackett Road
Modesto CA 95358
(209) 525-7216

"Do what you feel in your heart to be right, for you'll be criticized anyway". - Eleanor Roosevelt



>>> On 12/4/2014 at 3:56 PM, in message
<D4949A00FBFF804D87C7DC699787C48401031A7AAA@HDCEXCHMBN1.rescs.caldoj.local>, Keith Dann
<Keith.Dann@doj.ca.gov> wrote:

Good afternoon Sheriff Christianson

On behalf of the CLETS Advisory Committee (CAC) and CAC Chair Sam Spiegel, please find attached a request seeking your participation or a California State Sheriffs' Association (CSSA) representative for a meeting with the Director of the Department of Motor Vehicles.

Attached you will find full details. Hard copy to follow by mail.

Thank you,

Keith Dann, CLETS Executive Secretary
Assistant Bureau Chief
California Department of Justice
Bureau of Criminal Information and Analysis
Telephone: 916.227.3466
keith.dann@doj.ca.gov

CONFIDENTIALITY NOTICE: This communication with its contents may contain confidential and/or legally privileged information. It is solely for the use of the intended recipient(s). Unauthorized interception, review, use or disclosure is prohibited and may violate applicable laws including the Electronic Communications Privacy Act. If you are not the intended recipient, please contact the sender and destroy all copies of the communication.

KAMALA D. HARRIS
Attorney General

State of California
DEPARTMENT OF JUSTICE



December 4, 2014

**CLETS
ADVISORY
COMMITTEE**

Sam Spiegel
CA Peace Officers'
Association
Chair

Cuong Nguyen
Department of Justice

Evert Palmer
League of California Cities

Karen Wong
Office of Emergency
Services

Scott Howland
California Highway Patrol

Scott Marshall
CA State Sheriffs'
Association

Larry Spikes
CA State Association of
Counties

Cynthia Renaud
CA Police Chiefs Association

Frank Alvarez
Department of Motor
Vehicles

Marc Shaw
CA Peace Officers'
Association

Citrus Heights Police Department Chief Christopher W. Boyd
California Police Chiefs' Association President
P.O. Box 255745
Sacramento, CA 95865

RE: California Police Chiefs' Association (CPCA) Representative

Dear Chief Boyd: *Chris*

The CLETS Advisory Committee (CAC) is arranging a meeting with the Director of DMV to discuss issues pertinent to the automated sharing of DMV photos for law enforcement field use. I am seeking your participation or a representative for this meeting.

In anticipation of that meeting, once we have your designee, a meeting or conference call will be held to further identify the details of this request categorized below:

1. Electronic, interstate exchange of driver license and identification photos for law enforcement purposes via NLETS; and,
2. Facial recognition technology.

As a matter of history, the sharing of DMV photos has been a goal of the CAC for years. We now have an indication that the current administration is interested in our request, but desires more information and to better understand the importance of the request. To that end, our endeavor is to have CSSA, CPCA and CPOA represented in the meeting, preferably at the executive board level. We want to be able to punctuate the importance of the request from all three associations.

Please let me know, via email listed below, who the designated CPCA representative will be.

As always, please don't hesitate to contact me via cell if you have any questions or concerns. Thank you in advance for your support.

Sincerely,

Sam Spiegel, Chair-CLETS Advisory Committee
EMAIL: sam.spiegel@doj.ca.gov

For KAMALA D. HARRIS
Attorney General

Keith Dann

From: Leslie McGill <lmcgill@californiapolicechiefs.org>
Sent: Friday, January 09, 2015 3:38 PM
To: Keith Dann
Cc: sam.spiegel@me.com
Subject: CLETS Advisory Committee - CPCA - DMV Meeting

Importance: High

Keith:

I apologize for the late response, but Cal Chiefs' rep on this Advisory Committee will be Sandy Maraviov with Citrus Heights PD. Her contact information is below:

Support Services Manager
Citrus Heights Police Department
6315 Fountain Square Dr.
Citrus Heights, CA 95621
(916) 727-5557

Please let us know when you want to schedule the meeting. Thanks!

Leslie McGill, CAE | Executive Director
California Police Chiefs Association
PO Box 255745
Sacramento, CA 95865-5745
Direct : 916-325-9004
916-481-8000 phone | 916-481-8008 fax
916-804-3527 cell
lmcgill@californiapolicechiefs.org
www.californiapolicechiefs.org
Facebook: CalChiefs
Twitter: @CalChiefs

Serving as the voice of and resource of choice for California's municipal police chiefs.

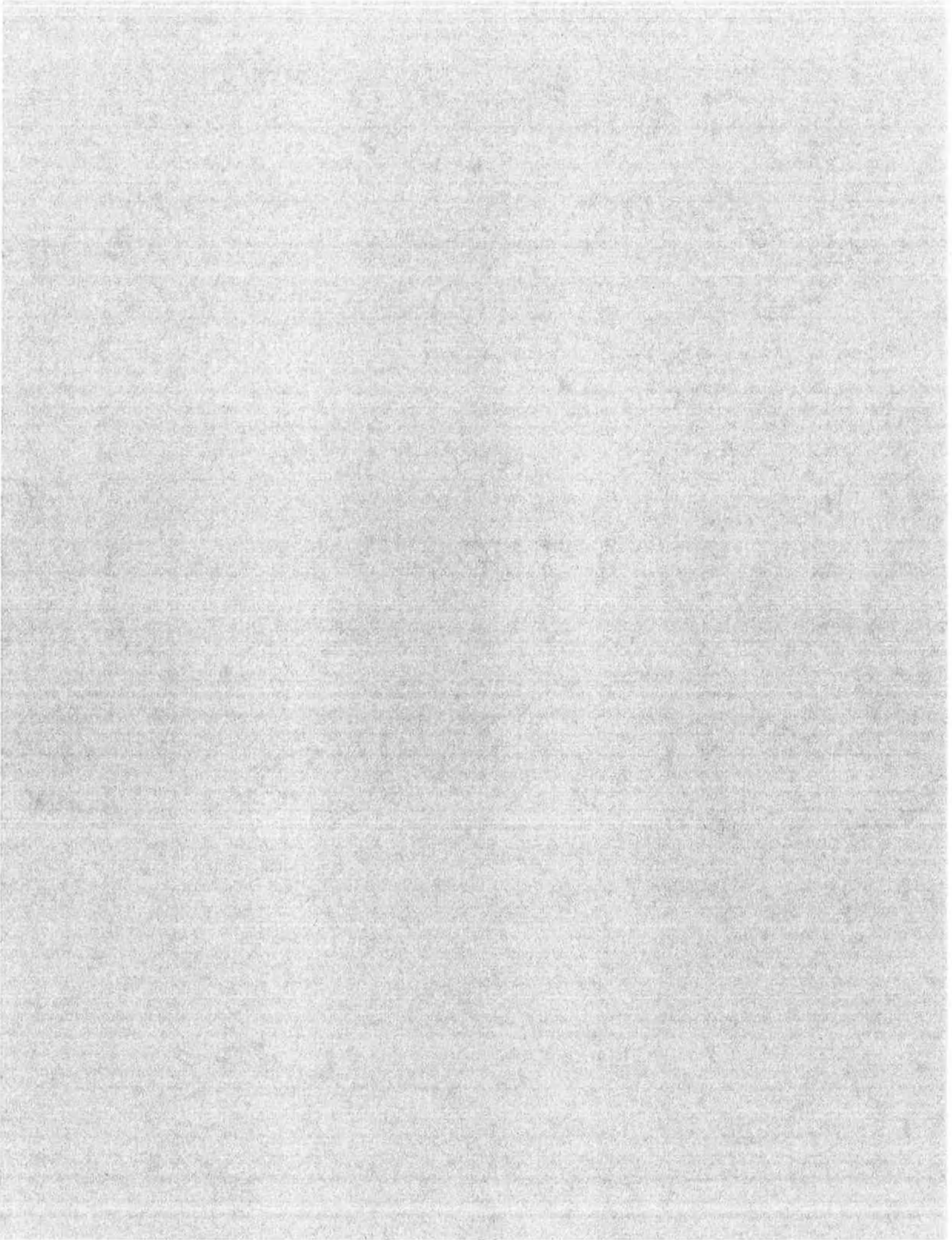

Kirk Beardwood

From: Julie Basco
Sent: Monday, December 22, 2014 1:33 PM
To: Kirk Beardwood
Subject: NLETS Brody Assistance Fund Grant

Follow Up Flag: Follow up
Flag Status: Flagged

Hi Kirk-

The NLETS project manager is Ted Rainer.

His telephone is 623-308-3547. He is domiciled in PA, not AZ. But, he said to not worry about the time zone difference.

His email is trainer@nlets.org.

I'd like to talk to you before you call him. He and I discussed a couple of things this afternoon.

Julie

Kirk Beardwood

From: Ted Rainer <trainer@nlets.org>
Sent: Tuesday, December 23, 2014 2:17 PM
To: Kirk Beardwood
Subject: Re: NLETS Photo Sharing - DQ Message

Kirk: I reviewed the attachment. Very similar to the SOW that was submitted with the BAF although CDI had been removed from the BAF submission. This will work just fine.

Did Julie discuss the storage procurement with you at all. I need to understand how Nlets can proceed on that side.

Thank you, Ted.

On Dec 23, 2014, at 2:10 PM, Kirk Beardwood <Kirk.Beardwood@doj.ca.gov> wrote:

I am not sure what was included in the BAF, I will request the document from Julie. Attached is what the vendor (CDI) supplied. This document is similar to the previous NLETS Chief Project which implemented XML for Criminal History Message Keys FQ, FR, and CR.

Thanks,
Kirk

From: Ted Rainer [mailto:trainer@nlets.org]
Sent: Tuesday, December 23, 2014 10:53 AM
To: Kirk Beardwood
Subject: Re: NLETS Photo Sharing - DQ Message

Mr. Beardwood: Nice to meet you and I look forward to working together on this project.

Per your question, do you have the BAF that was submitted to Nlets? If not, please request from Julie. At the end of the application, there is a statement of work that you could use as a template. Nlets does not have any requirement in terms of format.

What I do is take the SOW prepared by the client or contractor and cut/paste sections into an SOW section for the contract to be executed with your vendor.

If you would like to go through the SOW attached to the BAF, I'd be more than happy to get on a call and do that. Just let me know when it would be convenient for you.

Thank you,

Ted Rainer
623-308-3547

On Dec 23, 2014, at 11:26 AM, Kirk Beardwood <Kirk.Beardwood@doj.ca.gov> wrote:

Mr. Rainer,

My name is Kirk, and I will be leading the effort to retrieve photos through NLETS. I wanted to pass on my contact information and to check your availability. Julie mentioned that a "real" Statement of Work be created, do you have a template that we are required to use, or examples from other states?

Thanks,
Kirk Beardwood
CLETS Support Services Section Manager
California Department of Justice
(916) 227-3985 Office
(916) 201-0087 Mobile

Hi Kirk-

The NLETS project manager is Ted Rainer.

His telephone is 623-308-3547. He is domiciled in PA, not AZ. But, he said to not worry about the time zone difference.

His email is trainer@nlets.org.

I'd like to talk to you before you call him. He and I discussed a couple of things this afternoon.

Julie

CONFIDENTIALITY NOTICE: This communication with its contents may contain confidential and/or legally privileged information. It is solely for the use of the intended recipient(s). Unauthorized interception, review, use or disclosure is prohibited and may violate applicable laws including the Electronic Communications Privacy Act. If you are not the intended recipient, please contact the sender and destroy all copies of the communication.

CONFIDENTIALITY NOTICE: This communication with its contents may contain confidential and/or legally privileged information. It is solely for the use of the intended recipient(s). Unauthorized interception, review, use or disclosure is prohibited and may violate applicable laws including the Electronic Communications Privacy Act. If you are not the intended recipient, please contact the sender and destroy all copies of the communication. <California NLETS XML Photo Retrieval jfm.docx>

Kirk Beardwood

From: Ted Rainer <trainer@nlets.org>
Sent: Tuesday, December 23, 2014 10:53 AM
To: Kirk Beardwood
Subject: Re: NLETS Photo Sharing - DQ Message

Mr. Beardwood: Nice to meet you and I look forward to working together on this project.

Per your question, do you have the BAF that was submitted to Nlets? If not, please request from Julie. At the end of the application, there is a statement of work that you could use as a template. Nlets does not have any requirement in terms of format.

What I do is take the SOW prepared by the client or contractor and cut/paste sections into an SOW section for the contract to be executed with your vendor.

If you would like to go through the SOW attached to the BAF, I'd be more than happy to get on a call and do that. Just let me know when it would be convenient for you.

Thank you,

Ted Rainer
623-308-3547

On Dec 23, 2014, at 11:26 AM, Kirk Beardwood <Kirk.Beardwood@doj.ca.gov> wrote:

Mr. Rainer,

My name is Kirk, and I will be leading the effort to retrieve photos through NLETS. I wanted to pass on my contact information and to check your availability. Julie mentioned that a "real" Statement of Work be created, do you have a template that we are required to use, or examples from other states?

Thanks,
Kirk Beardwood
CLETS Support Services Section Manager
California Department of Justice
(916) 227-3985 Office
(916) 201-0087 Mobile

Hi Kirk-

The NLETS project manager is Ted Rainer.

His telephone is 623-308-3547. He is domiciled in PA, not AZ. But, he said to not worry about the time zone difference.

His email is trainer@nlets.org.

I'd like to talk to you before you call him. He and I discussed a couple of things this afternoon.

Julie

CONFIDENTIALITY NOTICE: This communication with its contents may contain confidential and/or legally privileged information. It is solely for the use of the intended recipient(s). Unauthorized interception, review, use or disclosure is prohibited and may violate applicable laws including the Electronic Communications Privacy Act. If you are not the intended recipient, please contact the sender and destroy all copies of the communication.

Niets Brodie Assistance Fund Application

Print Form

All fields must be must be completed or application will be denied - email completed form to blocke@nlets.org

Applicant Information

Name: JULIE BASCO Are you the Appointed Niets Rep?: YES Date: 12/11/14
Email: julie.basco@doj.ca.gov Organization: CA DOJ Phone #: 916.227-3854

Purpose Of Request

Type: SPECIAL PROJECT Date(s): DEC 2014 - APRIL 2015 Location: SACRAMENTO, CA
Event/Project Name & Description: INTERSTATE DL PHOTOGRAPH SHARING RETURN

Expenses

Event/Project Cost: \$50,000 Airfare:
Ground Transportation: # of Days: Transportation Total:
Parking: # of Days: Parking Total: Total expenses: \$50,000
Lodging Per Night: # of Nights: Lodging Total: # Of Attendees Applied for:
Daily Per Diem: # of Days: Per Diem Total: Total Amount Requested \$50,000

Name(s) of attendee(s)

THIS CERTIFICATION MANDATORY - Forms submitted without this box checked will be denied: By checking this box, I certify all financial avenues within the State have been exhausted; without BAF approval, there is no other way to fund this project/training.

Justification for request (minimum 500 words) Indicate problem statement and proposed solution. Use additional supporting documentation if necessary.

See attachments.

Return completed form to:
blocke@nlets.org

Niets Staff Use Only - Status & Comments

Received Date:
Approved?: YES NO
Comments, Notes, Name of Person Taking Action:

CALIFORNIA DEPARTMENT OF JUSTICE

NLETS - BRODY ASSISTANCE FUND

DECEMBER 2014

TO SAY THAT TODAY'S SOCIETY IS MOBILE IS A GROSS UNDERSTATEMENT. MILLIONS OF PEOPLE EFFORTLESSLY TRANSIT FROM ONE STATE TO ANOTHER EACH HOUR OF EVERY DAY. AS SUCH, THE DEPARTMENT OF JUSTICE'S (DOJ) PARTICIPATION IN NLETS INTER-STATE PHOTOGRAPH SHARING INITIATIVE, FOR DRIVER'S LICENSE PHOTOGRAPHS, WOULD PROVIDE CALIFORNIA LAW ENFORCEMENT AGENCIES A VALUABLE IDENTIFICATION TOOL.

THE DOJ HAS BEEN CONTEMPLATING PARTICIPATION IN THIS INITIATIVE FOR YEARS. THE BARRIER HAS BEEN SUSTAINING ENGAGEMENT FROM THE DEPARTMENT OF MOTOR VEHICLES (DMV) ON THE TOPIC OF ELECTRONIC SHARING OF CALIFORNIA DRIVER'S LICENSE PHOTOGRAPHS OUT OF STATE. BUT RECENTLY, PROGRESS HAS BEEN MADE THROUGH THE DOJ'S CALIFORNIA LAW ENFORCEMENT TELECOMMUNICATIONS SYSTEM (CLETS) ADVISORY COMMITTEE'S STANDING STRATEGIC PLANNING SUBCOMMITTEE (SSPS). THE SSPS RECOMMENDS STRATEGIC GOALS FOR THE CLETS AND HAS ADVANCED THIS TOPIC TO PRIORITY STATUS. THROUGH SSPS COORDINATION, THE THREE MAJOR CALIFORNIA LAW ENFORCEMENT ASSOCIATIONS AND THE DOJ WILL MEET WITH THE DMV DIRECTOR BEFORE MARCH 2015 TO DISCUSS THE DMV'S POLICY CONCERNS, INTEREST LEVEL AND MAP A PROGRESSIVE APPROACH TO PARTICIPATION. IN CALIFORNIA, THE DOJ IS PART OF THE OFFICE OF THE ATTORNEY GENERAL, A CONSTITUTIONAL OFFICE. THE DMV IS PART OF THE EXECUTIVE BRANCH OF GOVERNMENT REPORTING TO ANOTHER CONSTITUTIONAL OFFICER, THE GOVERNOR.

THE SSPS HAS DETERMINED THAT MOVING FORWARD TO ESTABLISH THE NECESSARY INFRASTRUCTURE TO ELECTRONICALLY RECEIVE DRIVER'S LICENSE PHOTOGRAPHS FROM OUT OF STATE WOULD BE HIGHLY BENEFICIAL AND ALSO, PROVIDE INCENTIVE TO THE DMV TO TAKE ACTION ON THIS TOPIC.

A STATEMENT OF WORK IS ATTACHED THAT DETAILS THE REQUEST FOR \$40,000 OF CONSULTING SERVICES AND \$10,000 FOR ADDITIONAL STORAGE AT THE DOJ.

IT IS KNOWN THAT BRODY ASSISTANCE FUND COMMITTEE HAS INTEREST IN THESE QUESTIONS; THEREFORE, A RESPONSE FOR EACH FOLLOWS:

IS THE FUNDING YOU ARE REQUESTING CONSIDERED SUPPORT AND MAINTENANCE?

NO. THE FUNDING WILL COVER ENHANCEMENTS TO BOTH THE CLETS AND THE SMARTJUSTICE APPLICATION. SMARTJUSTICE IS THE ATTORNEY'S GENERAL

MARQUIS DATA SHARING PLATFORM THAT DISPLAYS DOJ DATA SYSTEMS AND COUNTY LEVEL LAW ENFORCEMENT AND PROBATION DATA SYSTEMS IN A SINGLE VIEW, WITH A SINGLE SIGN-ON BOTH TERMINAL AND MOBILE DEVICES. ONCE THE ENHANCEMENTS ARE ACCOMPLISHED, THE MAINTENANCE AGREEMENTS FOR BOTH CLETS AND SMARTJUSTICE WILL ENGAGE.

HOW WILL YOU FUND THIS EFFORT WHEN BAF FUNDS ARE EXHAUSTED?

VIA THE CLETS AND SMARTJUSTICE MAINTENANCE AGREEMENTS. ALSO, IF FUTURE ENHANCEMENTS ARE NEEDED THE SMARTJUSTICE APPLICATION IS CONTINUALLY EVOLVING AND THE OPPORTUNITY WOULD EXIST TO BRING THIS EFFORT INTO THAT FUNDING ARENA.

PLEASE EXPLAIN HOW THIS REQUEST WILL BENEFIT OTHER STATES AND THE NLETS COMMUNITY AS A WHOLE?

IDENTIFICATION. CALIFORNIA LAW ENFORCEMENT WILL BE MORE READILY ABLE TO ENGAGE WITH OUT OF STATE AGENCIES REGARDING THEIR CITIZENS.

WHAT CAPABILITIES WILL BE LOST IF YOU DO NOT RECEIVE THIS BRODY ASSISTANCE FUND FUNDING FOR THIS EFFORT?

IDENTIFICATION OF OUT OF STATE INDIVIDUALS IN A REAL TIME SETTING.

HOW WILL THESE LOST CAPABILITIES IMPACT YOUR STATE AND THE STATES AROUND YOU?

CALIFORNIA LAW ENFORCEMENT WILL CONTINUE TO OPERATE IN A PAPER, FACSIMILE RELIANT PROCESS THAT JEOPARDIZES OFFICER SAFETY AND EFFICIENCY. IT IS BELIEVED THAT THE IMPLEMENTATION OF RECEIVING OUT OF STATE DRIVER'S LICENSE PHOTOGRAPHS ELECTRONICALLY WILL CREATE MOMENTUM FOR THE DMV TO ELECTRONICALLY SHARE CALIFORNIA DRIVER'S LICENSE PHOTOGRAPHS OUT OF STATE.

HOW ARE YOU ACCOMPLISHING THIS CURRENTLY?

THE DOJ IS NOT PARTICIPATING CURRENTLY.

IF YOUR BRODY ASSISTANCE FUND APPLICATION IS UNSUCCESSFUL, WHAT WILL THE TIMELINE BE FOR YOU TO ACCOMPLISH WITH STATE FUNDS?

UNDETERMINED AND UNLIKELY. THIS WOULD BE A GENERAL FUND REQUEST AND THE DOJ WOULD HAVE TO GIVE UP AN EQUAL GENERAL FUND AMOUNT, FROM THE CURRENT BUDGET, TO OFF-SET SUCH A REQUEST AND THE DOJ HAS NOT DONE THIS FOR MANY FISCAL YEARS.

Statement of Work

California Department of Justice

CLETS

Statement of Work

NLETS XML DL Photo Retrieval Effort

~~ Provided By ~~

CLETS Support Services Section

December 2014

Statement of Work

1 Background

The California Law Enforcement Telecommunications System (CLETS) is the state's message switch for the exchange of Law Enforcement data among California (local, county and state level) users and systems (e.g. ACHS and DMV); and external national and international users and systems via NCIC and NLETS.

- An XML based interface header structure designed to exchange legacy and XML message payloads is currently used between CLETS and California's New CJIS Control (NCC).
- CDI supported the successful implementation of a NIEM XML interface for the exchange of Criminal Rapsheets between California and other states via NLETS (CHIEF Project).
- CDI is currently supporting California's SmartJustice project which will be extended under this agreement to encompass the retrieval of other state driver photos via NLETS.

California DOJ is positioned to support a transition to XML based message formatting. The DL Photo Retrieval Project is a logical step in XML's implementation.

2 Proposal

California desires to participate in the NLETS DL Photo Retrieval using the National Information Exchange Model (NIEM) format for exchanging computerized Driver License data between NLETS and the CA DOJ. For CA DOJ, CLETS is a key architectural component to this effort.

This proposal is to provide the CLETS level XML specifications and testing support required of California to achieve a NLETS Photo Retrieval thru the SmartJustice Application Portal without disrupting the current processing of MSC transactions.

Statement of Work

The following Data flow diagram depicts the CLETS architectural position role in the processing of the DL Photo Retrieval message keys from the perspective of California requests for out-of-state DMV driver license photos.

CA DQ DMV Queries to Other States

December 2014

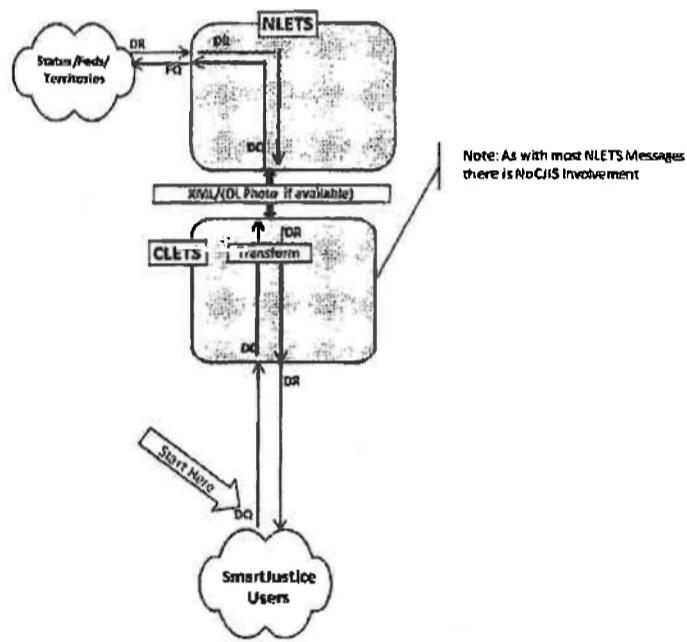

Assumptions/Description of Scope	Who is responsible
1. Within California, NLETS photos can only be retrieved via California's SmartJustice Application Portal.	NLETS/CLETS
2. SmartJustice DQ queries to out of state DMVs are received in JSON format. CLETS transforms these queries to Legacy format prior to sending them to NLETS.	NLETS/CLETS
3. All DR responses from NLETS are returned in NLETS NIEM format. CLETS uses NLETS provided style sheets (XSLT) to transform text content to its equivalent Legacy format prior its delivery. Photo content is extracted and forwarded to its SmartJustice user within a JSON structure.	NLETS/CLETS
4. California Department of Justice will only be a consumer of the NLETS DL Photos at this time. This effort does not include the sending of CA DMV Photos to NLETS.	NLETS/CLETS

Statement of Work

2.1 CA DOJ NLETS Photo Sharing Deliverables

CA DOJ shall be responsible to deliver the following:

- Define the following XML test instances:
 - JSON formatted DQ queries for transformation to NIEM XML or Legacy format for delivery to NLETS.
 - Transform NIEM XML formatted DR responses for transformation to JSON format for delivery to SmartJustice or Legacy format for SmartJustice or MSC users.
- Obtain and validate the XSLT stylesheets from NLETS for the transformations related to the DL Photo Retrieval Project:
- Define the CLETS components of the DL Photo Retrieval Project's Acceptance Testing in conjunction with the DOJ and NLETS members of the project team.
- Support user acceptance testing.

Statement of Work

3 Responsibilities

Each of the participating parties (NLETS and California DOJ) involved in this project will have certain responsibilities as described below:

NLETS Responsibilities:

- Provide (and maintain) DQ & DR interface and format requirements
- Identify non-California test cases and coordinate access to test systems
- Provide coordination of activity related to problem reporting and resolution
- Coordinate with CA DOJ the production implement and support

CLETS Specific Responsibilities:

- Identify the DQ and DR message format requirements
- Validate the requirements, correct and approve
- Document the testing message instances
- Provide CA DOJ with project task list
- Receive project plan, review and adhere to plan
- Support CLETS unit and integration level testing
- Coordinate system testing with NLETS and CA DOJ
- Track CLETS specific testing, requested corrections and retesting, as needed
- Provide ongoing support post-implementation

California DOJ Responsibilities:

- Provide support for the system environment to insure proper testing, operation and readiness
- Provide network connections to internal and external systems
- Provide remote access to the required CLETS DOJ User Systems, e.g., SmartJustice
- Coordinate system testing in cooperation with NLETS and other CA DOJ team participants
- Approve requirements
- Document requirements
- Coordinate software development and testing
- Coordinate and approve Acceptance
- Coordinate and approve Implementation

Statement of Work

4 Pricing

The following table presents the pricing associated with the tasks for this statement of work. In order for Vendor to deliver the working software in the required time frames, all parties must work closely together to insure that all required facilities are provided in a timely manner.

	Cost	Quantity	Total
Validate XSLT style sheets from NLETS for following transformations: <ul style="list-style-type: none"> • DQ JSON and Legacy to XML • DR XML to JSON and Legacy 	\$10,000.00	1	\$10,000.00
Define Test Instances <ul style="list-style-type: none"> • In State Requests to Other States (DQ and DR) 	\$10,000.00	1	\$10,000.00
Define CLETS and SmartJustice components of NLETS DL Photo Retrieval Project Acceptance Test Plan	\$10,000.00	1	\$10,000.00
Project Management, testing, support, and documentation	\$10,000.00	1	\$10,000.00
One (1) year warranty, maintenance and support	Included	1	Included
Total Cost			\$40,000.00

NOTE 1: Warranty shall commence after 10 days of production operation and included in existing CLETS maintenance contract.

NOTE 2: Any CLETS software changes (switch, configuration, and archive services) required to implement the NLETS Photo Sharing (DQ and DR) are not included under this Statement of Work and are subject to the existing maintenance support contract.

Kirk Beardwood

From: Julie Basco
Sent: Wednesday, January 28, 2015 11:44 AM
To: Kirk Beardwood
Subject: RE: NLETS Reimbursement for CLETS Storage MOU.docx

I think you can sign.

Sent from my Verizon Wireless 4G LTE smartphone

----- Original message -----

From: Kirk Beardwood <Kirk.Bearwood@doj.ca.gov>
Date: 01/28/2015 11:40 AM (GMT-08:00)
To: Julie Basco <Julie.Basco@doj.ca.gov>
Subject: FW: NLETS Reimbursement for CLETS Storage MOU.docx

Julie,

Is your signature required for the MOU between DOJ and NLETS for the \$10,000 storage component, or is this something that I can sign.

Thanks,
Kirk

From: Diana LaRue
Sent: Wednesday, January 28, 2015 10:07 AM
To: Kirk Beardwood
Subject: NLETS Reimbursement for CLETS Storage MOU.docx

Hi Kirk,

Nancy Mar asked me to add a Payment Method section to the MOU. Can you please take a look and let me know if you agree. Also, she asked if Julie has to sign the MOU or can you?

Kirk Beardwood

From: Bonnie Locke <blocke@nlets.org>
Sent: Monday, December 15, 2014 6:45 AM
To: Julie Basco
Subject: CONGRATULATIONS!

Importance: High

Julie - You DL (receiving only) BAF was approved!

You will be hearing from an Nlets PM within a couple of weeks.

Thank you,
Bonnie

Bonnie Locke

Nlets Director of Business Development

Office: (623) 308-3504 | Fax: (623) 308-3501
1918 W. Whispering Wind Dr. | Phoenix, AZ 85085
blocke@nlets.org | www.nlets.org

Nlets - the International Justice and Public Safety Network

Kirk Beardwood

From: Julie Basco
Sent: Friday, January 09, 2015 4:44 PM
To: Kirk Beardwood; Nancy Mar
Cc: Andrea BanuelosDavis
Subject: RE: NLETS MOU for CLETS Centera Storage Funds
Attachments: CONGRATULATIONS!

From: Kirk Beardwood
Sent: Friday, January 09, 2015 10:16 AM
To: Nancy Mar; Julie Basco
Cc: Andrea BanuelosDavis
Subject: Re: NLETS MOU for CLETS Centera Storage Funds

Julie,

Nancy Mar is requesting the BAF approval from NLETS. Ted believes it was sent on Dec. 15, 2014.

Thanks,
Kirk

On Jan 9, 2015, at 10:08 AM, Nancy Mar <Nancy.Mar@doj.ca.gov> wrote:

Can you get the approval email from Julie too?

From: Ted Rainer [<mailto:trainer@nlets.org>]
Sent: Friday, January 09, 2015 9:27 AM
To: Nancy Mar
Cc: Andrea BanuelosDavis; Richele Coy
Subject: Re: NLETS MOU for CLETS Centera Storage Funds

Nancy: Thank you for working with me to get CA the required funding for the storage hardware.

I had a quick thought, you probably should get the BAF approval e-mail from Julie since she is the Nlets rep. As a reminder to her, the acceptance e-mail was sent on 12/15. If she cannot find it, I can provide.

Thank you, Ted.

On Jan 9, 2015, at 11:42 AM, Nancy Mar <Nancy.Mar@doj.ca.gov> wrote:

Ted,

Just tried to call you. Please call us back at your earliest convenience. 916 227-3110

Thanks.

-Nancy Mar, Manager
Department of Justice
IT Contracts and Procurement Unit (ITCPU)
4949 Broadway, Room D232
Sacramento, CA 95820
Nancy.mar@doj.ca.gov
(916) 227-3110 work
(916) 870-3815 mobile
Work hours: M-F 8:45 AM-5:15 PM

From: Ted Rainer [mailto:trainer@nlets.org]
Sent: Friday, January 09, 2015 7:42 AM
To: Andrea BanuelosDavis
Cc: Nancy Mar; Richele Coy
Subject: Re: NLETS MOU for CLETS Centera Storage Funds

Andrea: Thank you for the prompt reply. I just left you a v-mail. Pretty much any time except from 8:00-8:30 your time. Ted.

On Jan 9, 2015, at 10:36 AM, Andrea BanuelosDavis <Andrea.BanuelosDavis@doj.ca.gov> wrote:

Yes, please let me know what time works for you.

From: Ted Rainer [mailto:trainer@nlets.org]
Sent: Thursday, January 08, 2015 6:24 PM
To: Andrea BanuelosDavis
Cc: Nancy Mar; Richele Coy
Subject: Re: NLETS MOU for CLETS Centera Storage Funds

Andrea: I think there may have been a mis-communication here. Will you be available for a call tomorrow (Friday) so I can explain my concerns.

Thank you, Ted.
623-308-3547

On Jan 8, 2015, at 2:27 PM, Andrea BanuelosDavis <Andrea.BanuelosDavis@doj.ca.gov> wrote:

Hi Ted,

Per my voice mail, Kirk Beardwood has requested we work with NLETS to create a Memorandum of Understanding (MOU) to obtain funds to purchase additional CLETS Centera storage. Could you please draft the MOU and send to me for review?

Andrea Banuelos-Davis

Department of Justice
Information Technology Contracts and Procurement Unit
4949 Broadway, D-232
Sacramento, CA 95820
(916) 227-3195

CONFIDENTIALITY NOTICE: This communication with its contents may contain confidential and/or legally privileged information. It is solely for the use of the intended recipient(s). Unauthorized interception, review, use or disclosure is prohibited and may violate applicable laws including the Electronic Communications Privacy Act. If you are not the intended recipient, please contact the sender and destroy all copies of the communication.

CONFIDENTIALITY NOTICE: This communication with its contents may contain confidential and/or legally privileged information. It is solely for the use of the intended recipient(s). Unauthorized interception, review, use or disclosure is prohibited and may violate applicable laws including the Electronic Communications Privacy Act. If you are not the intended recipient, please contact the sender and destroy all copies of the communication.

CONFIDENTIALITY NOTICE: This communication with its contents may contain confidential and/or legally privileged information. It is solely for the use of the intended recipient(s). Unauthorized interception, review, use or disclosure is prohibited and may violate applicable laws including the Electronic Communications Privacy Act. If you are not the intended recipient, please contact the sender and destroy all copies of the communication.

Kirk Beardwood

From: Ted Rainer <trainer@nlets.org>
Sent: Tuesday, December 30, 2014 11:37 AM
To: Kirk Beardwood
Subject: Re: NLETS Photo Sharing - DQ Message

Kirk: No worries. I will review your changes and get back to you with any questions.

Thank you and have a great and safe New Year.

Ted.

On Dec 30, 2014, at 12:25 PM, Kirk Beardwood <Kirk.Bearwood@doj.ca.gov> wrote:

Ted,

My apologies for the late reply. Please see the attached updated document.

Section 2 CDI Participation The section in yellow can be removed/deleted. Another yellow bullet was removed due to redundancy.

The comment in N2 was updated.

FQ was fixed in diagram

Removed Section 2.2 and incorporated into Section 3.

I am still looking into the storage portion of the project.

Thanks,
Kirk

From: Ted Rainer [mailto:trainer@nlets.org]
Sent: Friday, December 26, 2014 9:02 AM
To: Kirk Beardwood
Subject: Re: NLETS Photo Sharing - DQ Message

Kirk: Hope you had a great Christmas. I have incorporated the CDI SOW with the Nlets contract language. The contract language is pretty much the same as CDI agreed to for CHIEF.

In the statement of work, I have highlighted in yellow section that we need to discuss along with several Word comments.

Please let me know at your earliest convenience when we could have a call to discuss.

Thank you, Ted

CONFIDENTIALITY NOTICE: This communication with its contents may contain

confidential and/or legally privileged information. It is solely for the use of the intended recipient(s). Unauthorized interception, review, use or disclosure is prohibited and may violate applicable laws including the Electronic Communications Privacy Act. If you are not the intended recipient, please contact the sender and destroy all copies of the communication. <CDI_CA_001_2014_Consulting_Agreement_JFM.docx>

Kirk Beardwood

From: Ted Rainer <trainer@nlets.org>
Sent: Wednesday, December 31, 2014 8:29 AM
To: Kirk Beardwood
Subject: Re: NLETS Photo Sharing - DQ Message
Attachments: CDI_CA_001_2014_Consulting_Agreement.pdf; ATT00001.htm

Kirk: Here is a PDF of the CDI contract with all changes updated. Please have CDI sign page 5 and initial each page in the upper right hand corner (next to CDI Initial). Scan and return to me. I will submit to the Nlets procurement process. This will result in an executed copy and PO which I will return to you for delivery to CDI.

Thank you and have a great New Year. Ted.

Kirk Beardwood

From: Ted Rainer <trainer@nlets.org>
Sent: Monday, January 05, 2015 5:27 PM
To: Don Foulk
Cc: Kirk Beardwood
Subject: Re: NLETS Photo Sharing - DQ Message

Don: Appreciate you doing this. I'll use this one. Thank you, Ted.

On Jan 5, 2015, at 5:01 PM, Don Foulk <Don.Foulk@doj.ca.gov> wrote:

Ted: Attached is a replacement of the prior submission. I annotated page 5, to reflect the transpose of the "OI" required for the correct spelling of "DEDUCTION" and initialed the change. If this is acceptable, you can initial it also.

If you choose, to proceed without the annotation that is acceptable to CDI.

Thanks,
Donald Foulk, Vice President
Computer Deductions, Inc.

From: Ted Rainer [mailto:trainer@nlets.org]
Sent: Monday, January 05, 2015 12:22 PM
To: Kirk Beardwood
Cc: Don Foulk
Subject: Re: NLETS Photo Sharing - DQ Message

Kirk: Received. Unless someone objects, I will submit with the signature block as is otherwise if I change anything, I will have to get someone from CDI to initial before submitting to the Nlets procurement process.

I will update my Word doc so this is not perpetuated in the future.

Thank you, Ted.
On Jan 5, 2015, at 11:38 AM, Kirk Beardwood <Kirk.Beardwood@doj.ca.gov> wrote:

Ted,

Attached is a signed PDF. Please see comments by Don Foulk regarding CDI Signature Block on page 5 of the document. CDI signature block is miss typed, "DEDUCTOIN" instead of "DEDUCTIONS"

Thanks,
Kirk

From: Don Foulk
Sent: Friday, January 02, 2015 11:53 AM
To: Kirk Beardwood
Cc: john.macdonnell@cdi-hq.com
Subject: RE: NLETS Photo Sharing - DQ Message

Attached is the signed and initialed NLETS Contract with CDI

Thanks

Don

DOJ # 916-227-1107
Cell# 916-501-0814 (unavailable when at DOJ)

From: Don Foulk
Sent: Wednesday, December 31, 2014 11:13 AM
To: Kirk Beardwood
Cc: john.macdonnell@cdi-hq.com
Subject: RE: NLETS Photo Sharing - DQ Message

The document is setup for me to sign, not John. I will sign and bring in Friday morning for scanning and return.

I just noticed that the CDI signature block is miss typed, "DEDUCTOIN" instead of "DEDUCTIONS"

Thanks

Don

DOJ # 916-227-1107
Cell# 916-501-0814 (unavailable when at DOJ)

From: Kirk Beardwood
Sent: Wednesday, December 31, 2014 9:55 AM
To: Don Foulk
Subject: Fwd: NLETS Photo Sharing - DQ Message

FYI

Thanks,
Kirk

Begin forwarded message:

From: Ted Rainer <trainer@nlets.org>
Date: December 31, 2014 at 8:29:08 AM PST
To: Kirk Beardwood <Kirk.Beardwood@doj.ca.gov>
Subject: Re: NLETS Photo Sharing - DQ Message

Kirk: Here is a PDF of the CDI contract with all changes updated. Please have CDI sign page 5 and initial each page in the upper right hand corner (next to CDI Initial). Scan and return to me. I will submit to the Nlets procurement process. This will result in an executed copy and PO which I will return to you for delivery to CDI.

Thank you and have a great New Year. Ted.

CONFIDENTIALITY NOTICE: This communication with its contents may contain confidential and/or legally privileged information. It is solely for the use of the intended

recipient(s). Unauthorized interception, review, use or disclosure is prohibited and may violate applicable laws including the Electronic Communications Privacy Act. If you are not the intended recipient, please contact the sender and destroy all copies of the communication. <NLETS Photo PO CDI Signed.pdf>

CONFIDENTIALITY NOTICE: This communication with its contents may contain confidential and/or legally privileged information. It is solely for the use of the intended recipient(s). Unauthorized interception, review, use or disclosure is prohibited and may violate applicable laws including the Electronic Communications Privacy Act. If you are not the intended recipient, please contact the sender and destroy all copies of the communication. <NLETS Photo PO CDI Signed - with Page 5 Annotated.pdf>

Kirk Beardwood

From: Ted Rainer <trainer@nlets.org>
Sent: Thursday, January 08, 2015 4:24 AM
To: Kirk Beardwood
Subject: Re: NLETS Photo Sharing - DQ Message

No, this will do. I will submit the contract tomorrow for Nlets approval. Ted.

On Jan 7, 2015, at 9:47 PM, Kirk Beardwood <Kirk.Beardwood@doj.ca.gov> wrote:

Short answer is yes, CA will implement the changes outlined in the CDI contract. I expect to be testing the XML in the middle of February and working out our data archiving in March with a production release in April.

My fear is the MOU for storage will take time as it is out of my control, and involves different areas.

If you require further verification from my superiors, let me know.

Thanks,
Kirk

On Jan 7, 2015, at 6:03 PM, Ted Rainer <trainer@nlets.org> wrote:

Yes I can but I am a bit concerned if we can't come to some arrangement with the storage, will CA still be able to implement the DL Photo software changes?

I don't want to commit Nlets \$\$ to a contract if the project will not be successful because of no storage hardware.

If CA can commit to implementing even if we cannot get you the storage component, then I will go ahead with the contract piece.

Hope this clarifies. Ted.

On Jan 7, 2015, at 8:47 PM, Kirk Beardwood <Kirk.Beardwood@doj.ca.gov> wrote:

Ted,

Are you able to proceed with the CDI contract, and process the DOJ storage MOU separately?

Thanks,
Kirk

On Jan 7, 2015, at 4:01 PM, Ted Rainer <trainer@nlets.org> wrote:

Kirk: Thank you, I hope we can get a speedy resolution so you can make your timelines for DL Photo sharing.

Take care, Ted.

On Jan 7, 2015, at 2:24 PM, Kirk Beardwood <Kirk.Beardwood@doj.ca.gov> wrote:

Ted,

I have spoken with our Contracts Unit, and I am adding Nancy to my reply. Nancy will be addressing the hardware portion of the contract. I included the CDI contract for Nancy's benefit.

Nancy Mar
(916) 227-3110

Thanks,
Kirk

From: Ted Rainer [mailto:trainer@nlets.org]
Sent: Monday, January 05, 2015 1:13 PM
To: Kirk Beardwood
Subject: Re: NLETS Photo Sharing - DQ Message

Kirk; Any thoughts on the hardware side. I'd like to get that nailed down (or at least a probably solution) before I submit the CDI contract for Nlets approval.

Thank you, Ted.

On Jan 5, 2015, at 11:38 AM, Kirk Beardwood <Kirk.Beardwood@doj.ca.gov> wrote:

Ted,

Attached is a signed PDF. Please see comments by Don Foulk regarding CDI Signature Block on page 5 of the document.

CDI signature block is miss typed, "DEDUCTOIN" instead of "DEDUCTIONS"

Thanks,
Kirk

From: Don Foulk
Sent: Friday, January 02, 2015 11:53 AM
To: Kirk Beardwood
Cc: john.macdonnell@cdi-hq.com
Subject: RE: NLETS Photo Sharing - DQ Message

Attached is the signed and initialed NLETS Contract with CDI

Thanks

Don

DOJ # 916-227-1107
Cell# 916-501-0814 (unavailable when at DOJ)

From: Don Foulk
Sent: Wednesday, December 31, 2014 11:13 AM
To: Kirk Beardwood
Cc: john.macdonnell@cdi-hq.com
Subject: RE: NLETS Photo Sharing - DQ Message

The document is setup for me to sign, not John. I will sign and bring in Friday morning for scanning and return.

I just noticed that the CDI signature block is miss typed, "DEDUCTOIN" instead of "DEDUCTIONS"

Thanks

Don

DOJ # 916-227-1107
Cell# 916-501-0814 (unavailable when at DOJ)

From: Kirk Beardwood
Sent: Wednesday, December 31, 2014 9:55 AM
To: Don Foulk
Subject: Fwd: NLETS Photo Sharing - DQ Message

FYI

Thanks,
Kirk

Begin forwarded message:

From: Ted Rainer <trainer@nlets.org>
Date: December 31, 2014 at 8:29:08 AM PST
To: Kirk Beardwood <Kirk.Beardwood@doj.ca.gov>
Subject: Re: NLETS Photo Sharing - DQ Message

Kirk: Here is a PDF of the CDI contract with all changes updated. Please have CDI sign page 5 and initial each page in the upper right hand corner (next to CDI Initial). Scan and return to me. I will submit to the Nlets procurement process. This will result in an executed copy and PO which I will return to you for delivery to CDI.

Thank you and have a great New Year. Ted.

CONFIDENTIALITY NOTICE: This communication with its contents may contain confidential and/or legally privileged

information. It is solely for the use of the intended recipient(s). Unauthorized interception, review, use or disclosure is prohibited and may violate applicable laws including the Electronic Communications Privacy Act. If you are not the intended recipient, please contact the sender and destroy all copies of the communication. <NLETS Photo PO CDI Signed.pdf>

CONFIDENTIALITY NOTICE: This communication with its contents may contain confidential and/or legally privileged information. It is solely for the use of the intended recipient(s). Unauthorized interception, review, use or disclosure is prohibited and may violate applicable laws including the Electronic Communications Privacy Act. If you are not the intended recipient, please contact the sender and destroy all copies of the communication. <NLETS Photo PO CDI Signed - with Page 5 Annotated.pdf>

CONFIDENTIALITY NOTICE: This communication with its contents may contain confidential and/or legally privileged information. It is solely for the use of the intended recipient(s). Unauthorized interception, review, use or disclosure is prohibited and may violate applicable laws including the Electronic Communications Privacy Act. If you are not the intended recipient, please contact the sender and destroy all copies of the communication.

CONFIDENTIALITY NOTICE: This communication with its contents may contain confidential and/or legally privileged information. It is solely for the use of the intended recipient(s). Unauthorized interception, review, use or disclosure is prohibited and may violate applicable laws including the Electronic Communications Privacy Act. If you are not the intended recipient, please contact the sender and destroy all copies of the communication.

Kirk Beardwood

From: Ted Rainer <trainer@nlets.org>
Sent: Tuesday, January 27, 2015 6:54 AM
To: Kirk Beardwood
Subject: Re: NLETS Photo Sharing - DQ Message

Kirk: I hope all is well and I didn't want you to think Nlets had forgotten you.

CDI contract is still in procurement. It normally does not take this long but each year Nlets closes all PO and assigns new one. Also this year Nlets is migrating to new financial management system... soooo it is taking longer than normal to get contracts through the procurement process but I can assure you that it is moving forward.

Ted.

On Jan 7, 2015, at 9:47 PM, Kirk Beardwood <Kirk.Beardwood@doj.ca.gov> wrote:

Short answer is yes, CA will implement the changes outlined in the CDI contract. I expect to be testing the XML in the middle of February and working out our data archiving in March with a production release in April.

My fear is the MOU for storage will take time as it is out of my control, and involves different areas.

If you require further verification from my superiors, let me know.

Thanks,
Kirk

On Jan 7, 2015, at 6:03 PM, Ted Rainer <trainer@nlets.org> wrote:

Yes I can but I am a bit concerned if we can't come to some arrangement with the storage, will CA still be able to implement the DL Photo software changes?

I don't want to commit Nlets \$s to a contract if the project will not be successful because of no storage hardware.

If CA can commit to implementing even if we cannot get you the storage component, then I will go ahead with the contract piece.

Hope this clarifies. Ted.

On Jan 7, 2015, at 8:47 PM, Kirk Beardwood <Kirk.Beardwood@doj.ca.gov> wrote:

Ted,

Are you able to proceed with the CDI contract, and process the DOJ storage MOU separately?

Thanks,
Kirk

On Jan 7, 2015, at 4:01 PM, Ted Rainer <trainer@nlets.org> wrote:

Kirk: Thank you, I hope we can get a speedy resolution so you can make your timelines for DL Photo sharing.

Take care, Ted.

On Jan 7, 2015, at 2:24 PM, Kirk Beardwood <Kirk.Beardwood@doj.ca.gov> wrote:

Ted,

I have spoken with our Contracts Unit, and I am adding Nancy to my reply. Nancy will be addressing the hardware portion of the contract. I included the CDI contract for Nancy's benefit.

Nancy Mar
(916) 227-3110

Thanks,
Kirk

From: Ted Rainer [mailto:trainer@nlets.org]
Sent: Monday, January 05, 2015 1:13 PM
To: Kirk Beardwood
Subject: Re: NLETS Photo Sharing - DQ Message

Kirk; Any thoughts on the hardware side. I'd like to get that nailed down (or at least a probable solution) before I submit the CDI contract for Nlets approval.

Thank you, Ted.

On Jan 5, 2015, at 11:38 AM, Kirk Beardwood <Kirk.Beardwood@doj.ca.gov> wrote:

Ted,

Attached is a signed PDF. Please see comments by Don Foulk regarding CDI Signature Block on page 5 of the document.

CDI signature block is miss typed, "DEDUCTOIN" instead of "DEDUCTIONS"

Thanks,
Kirk

From: Don Foulk
Sent: Friday, January 02, 2015 11:53 AM
To: Kirk Beardwood
Cc: john.macdonnell@cdi-hq.com
Subject: RE: NLETS Photo Sharing - DQ Message

Attached is the signed and initialed NLETS Contract with CDI

Thanks

Don

DOJ # 916-227-1107
Cell# 916-501-0814 (unavailable when at DOJ)

From: Don Foulk
Sent: Wednesday, December 31, 2014 11:13 AM
To: Kirk Beardwood
Cc: john.macdonnell@cdi-hq.com
Subject: RE: NLETS Photo Sharing - DQ Message

The document is setup for me to sign, not John. I will sign and bring in Friday morning for scanning and return.

I just noticed that the CDI signature block is miss typed, "DEDUCTOIN" instead of "DEDUCTIONS"

Thanks

Don

DOJ # 916-227-1107
Cell# 916-501-0814 (unavailable when at DOJ)

From: Kirk Beardwood
Sent: Wednesday, December 31, 2014 9:55 AM
To: Don Foulk
Subject: Fwd: NLETS Photo Sharing - DQ Message

FYI

Thanks,
Kirk

Begin forwarded message:

From: Ted Rainer <trainer@nlets.org>
Date: December 31, 2014 at 8:29:08 AM PST
To: Kirk Beardwood <Kirk.Beardwood@doj.ca.gov>
Subject: Re: NLETS Photo Sharing - DQ Message

Kirk: Here is a PDF of the CDI contract with all changes updated. Please have CDI sign page 5 and initial each page in the upper right hand corner (next to CDI Initial). Scan and return to me. I will submit to the Nlets procurement process. This will

result in an executed copy and PO which I will return to you for delivery to CDI.

Thank you and have a great New Year. Ted.

CONFIDENTIALITY NOTICE: This communication with its contents may contain confidential and/or legally privileged information. It is solely for the use of the intended recipient(s). Unauthorized interception, review, use or disclosure is prohibited and may violate applicable laws including the Electronic Communications Privacy Act. If you are not the intended recipient, please contact the sender and destroy all copies of the communication. <NLETS Photo PO CDI Signed.pdf>

CONFIDENTIALITY NOTICE: This communication with its contents may contain confidential and/or legally privileged information. It is solely for the use of the intended recipient(s). Unauthorized interception, review, use or disclosure is prohibited and may violate applicable laws including the Electronic Communications Privacy Act. If you are not the intended recipient, please contact the sender and destroy all copies of the communication. <NLETS Photo PO CDI Signed - with Page 5 Annotated.pdf>

CONFIDENTIALITY NOTICE: This communication with its contents may contain confidential and/or legally privileged information. It is solely for the use of the intended recipient(s). Unauthorized interception, review, use or disclosure is prohibited and may violate applicable laws including the Electronic Communications Privacy Act. If you are not the intended recipient, please contact the sender and destroy all copies of the communication.

CONFIDENTIALITY NOTICE: This communication with its contents may contain confidential and/or legally privileged information. It is solely for the use of the intended recipient(s). Unauthorized interception, review, use or disclosure is prohibited and may violate applicable laws including the Electronic Communications Privacy Act. If you are not the intended recipient, please contact the sender and destroy all copies of the communication.

Kirk Beardwood

From: Ted Rainer <trainer@nlets.org>
Sent: Tuesday, January 27, 2015 10:44 AM
To: Kirk Beardwood
Subject: Re: NLETS Photo Sharing - DQ Message

Yes, I spoke with Diana LaRue today and she now has the ball. She was saying that they reached out to you for some Nlets contact information. I should be the primary contact and the Nlets address should be in the CDI contract.

If the MOU needs an Nlets officer contact, it should be Steve Correll (Director of Nlets).

If you need more, please let me know.

Ted.

On Jan 27, 2015, at 1:35 PM, Kirk Beardwood <Kirk.Beardwood@doj.ca.gov> wrote:

I appreciate the update. I hear my side is very close on the storage piece.

Thanks,
Kirk

On Jan 27, 2015, at 6:54 AM, Ted Rainer <trainer@nlets.org> wrote:

Kirk: I hope all is well and I didn't want you to think Nlets had forgotten you.

CDI contract is still in procurement. It normally does not take this long but each year Nlets closes all PO and assigns new one. Also this year Nlets is migrating to new financial management system.... soooo it is taking longer than normal to get contracts through the procurement process but I can assure you that it is moving forward.

Ted.

On Jan 7, 2015, at 9:47 PM, Kirk Beardwood <Kirk.Beardwood@doj.ca.gov> wrote:

Short answer is yes, CA will implement the changes outlined in the CDI contract. I expect to be testing the XML in the middle of February and working out our data archiving in March with a production release in April.

My fear is the MOU for storage will take time as it is out of my control, and involves different areas.

If you require further verification from my superiors, let me know.

Thanks,
Kirk

On Jan 7, 2015, at 6:03 PM, Ted Rainer <trainer@nlets.org> wrote:

Yes I can but I am a bit concerned if we can't come to some arrangement with the storage, will CA still be able to implement the DL Photo software changes?

I don't want to commit Nlets \$\$ to a contract if the project will not be successful because of no storage hardware.

If CA can commit to implementing even if we cannot get you the storage component, then I will go ahead with the contract piece.

Hope this clarifies. Ted.

On Jan 7, 2015, at 8:47 PM, Kirk Beardwood <Kirk.Beardwood@doj.ca.gov> wrote:

Ted,

Are you able to proceed with the CDI contract, and process the DOJ storage MOU separately?

Thanks,
Kirk

On Jan 7, 2015, at 4:01 PM, Ted Rainer <trainer@nlets.org> wrote:

Kirk: Thank you, I hope we can get a speedy resolution so you can make your timelines for DL Photo sharing.

Take care, Ted.

On Jan 7, 2015, at 2:24 PM, Kirk Beardwood <Kirk.Beardwood@doj.ca.gov> wrote:

Ted,

I have spoken with our Contracts Unit, and I am adding Nancy to my reply. Nancy will be addressing the hardware portion of the contract. I included the CDI contract for Nancy's benefit.

Nancy Mar
(916) 227-3110

Thanks,

Kirk

From: Ted Rainer [mailto:trainer@nlets.org]
Sent: Monday, January 05, 2015 1:13 PM
To: Kirk Beardwood
Subject: Re: NLETS Photo Sharing - DQ Message

Kirk; Any thoughts on the hardware side. I'd like to get that nailed down (or at least a probable solution) before I submit the CDI contract for Nlets approval.

Thank you, Ted.

On Jan 5, 2015, at 11:38 AM, Kirk Beardwood
<Kirk.Bearwood@doj.ca.gov> wrote:

Ted,

Attached is a signed PDF. Please see comments by Don Foulk regarding CDI Signature Block on page 5 of the document.
CDI signature block is miss typed, "DEDUCTOIN" instead of "DEDUCTIONS"

Thanks,
Kirk

From: Don Foulk
Sent: Friday, January 02, 2015 11:53 AM
To: Kirk Beardwood
Cc: john.macdonnell@cdi-hq.com
Subject: RE: NLETS Photo Sharing - DQ Message

Attached is the signed and initialed NLETS Contract with CDI

Thanks

Don

DOJ # 916-227-1107
Cell# 916-501-0814 (unavailable when at DOJ)

From: Don Foulk
Sent: Wednesday, December 31, 2014 11:13 AM
To: Kirk Beardwood
Cc: john.macdonnell@cdi-hq.com
Subject: RE: NLETS Photo Sharing - DQ Message

The document is setup for me to sign, not John. I will sign and bring in Friday morning for scanning and return.

I just noticed that the CDI signature block is miss typed, "DEDUCTOIN" instead of "DEDUCTIONS"

Thanks

Don

DOJ # 916-227-1107
Cell# 916-501-0814 (unavailable when at DOJ)

From: Kirk Beardwood
Sent: Wednesday, December 31, 2014 9:55 AM
To: Don Foulk
Subject: Fwd: NLETS Photo Sharing - DQ Message

FYI

Thanks,
Kirk

Begin forwarded message:

From: Ted Rainer <trainer@nlets.org>
Date: December 31, 2014 at 8:29:08 AM PST
To: Kirk Beardwood
<Kirk.Beardwood@doj.ca.gov>
Subject: Re: NLETS Photo Sharing - DQ Message

Kirk: Here is a PDF of the CDI contract with all changes updated. Please have CDI sign page 5 and initial each page in the upper right hand corner (next to CDI Initial). Scan and return to me. I will submit to the Nlets procurement process. This will result in an executed copy and PO which I will return to you for delivery to CDI.

Thank you and have a great New Year. Ted.

CONFIDENTIALITY NOTICE: This communication with its contents may contain confidential and/or legally privileged information. It is solely for the use of the intended recipient(s). Unauthorized interception, review, use or disclosure is prohibited and may violate applicable laws including the Electronic Communications Privacy Act. If you are not the intended recipient, please contact the sender and destroy all copies of the communication. <NLETS Photo PO CDI Signed.pdf>

CONFIDENTIALITY NOTICE: This communication with its contents may contain confidential and/or

legally privileged information. It is solely for the use of the intended recipient(s). Unauthorized interception, review, use or disclosure is prohibited and may violate applicable laws including the Electronic Communications Privacy Act. If you are not the intended recipient, please contact the sender and destroy all copies of the communication. <NLETS Photo PO CDI Signed - with Page 5 Annotated.pdf>

CONFIDENTIALITY NOTICE: This communication with its contents may contain confidential and/or legally privileged information. It is solely for the use of the intended recipient(s). Unauthorized interception, review, use or disclosure is prohibited and may violate applicable laws including the Electronic Communications Privacy Act. If you are not the intended recipient, please contact the sender and destroy all copies of the communication.

CONFIDENTIALITY NOTICE: This communication with its contents may contain confidential and/or legally privileged information. It is solely for the use of the intended recipient(s). Unauthorized interception, review, use or disclosure is prohibited and may violate applicable laws including the Electronic Communications Privacy Act. If you are not the intended recipient, please contact the sender and destroy all copies of the communication.

CONFIDENTIALITY NOTICE: This communication with its contents may contain confidential and/or legally privileged information. It is solely for the use of the intended recipient(s). Unauthorized interception, review, use or disclosure is prohibited and may violate applicable laws including the Electronic Communications Privacy Act. If you are not the intended recipient, please contact the sender and destroy all copies of the communication.

Nlets Contract No. _____

Nlets Initial _____

CDI Initial dg

**NLETS, THE INTERNATIONAL JUSTICE & PUBLIC SAFETY NETWORK
PROFESSIONAL SERVICES SERVICE AGREEMENT**

THIS PROFESSIONAL SERVICES AGREEMENT is made between **Nlets, the International Justice & Public Safety Network ("Nlets")**, and Contractor, **Computer Deductions, Inc. ("CDI")**.

PRINCIPAL ADDRESS OF CONTRACTOR:

8680 Greenback Lane, Suite 210
Orangevale, CA 95662

Contractor Primary and Accounting Contacts:

Don Foulk, Primary Contact

Phone: (916) 501-0814 Cell
(916) 227-1107 CA DOJ

E-Mail: Don.Foulk@doj.ca.gov

John MacDonnell, Accounting Contact

Phone: (916) 987-3600 CDI
(916) 539-4656 Cell

Email: John.MacDonnell@doj.ca.gov

IT IS AGREED AS FOLLOWS: CPI shall provide professional services for Nlets, unless mutually agreed otherwise by the parties, as follows:

1. **SCOPE OF WORK:**

CDI will provide professional services to support the California Department of Justice's ("CA DOJ") and develop the Driver's License Photo Sharing (DQ/DR) Message Keys (MKEs) for them. The MKEs will be based on the Nlets XML Message Structure and include the standard Nlets XML Header. Driver's License Photo queries and responses are specified based on NIEM (National Information Exchange Model) XML, while the Nlets XML Header and Message Structure will remain based on GJXDM. The services will derive from the categories and tasks itemized in the Nlets Driver's License Photos Statement of Work (SOW), Attachment A, which are specifically assigned to CDI. CDI will provide a Project Leader to oversee, coordinate and prioritize among the tasks itemized in the SOW. Tasks will be assigned in scheduled phases, according to a Project Plan to be developed and revised as necessary by the Nlets Project Manager, CDI's Project Leader, and CA DOJ's Point of Contact. Both Nlets & DCI will provide CDI with access to staff and any other

Nlets Contract No. _____

Nlets Initial _____

CDI Initial *dy*

resources, including data dictionaries, XML schemas and transformation artifacts necessary for CDI to provide the services.

2. **COMPENSATION:**

This is a firm, fixed price contract. Nlets shall compensate CDI for services rendered at a fixed rate of \$40,000.00 which includes the Software Customization, Switch Configuration, Testing, Project Management; and one (1) year warranty, maintenance and support. The fixed fee compensation is all inclusive and includes payment for all work performed, travel expenses, taxes of any type and any other costs incurred by the contractor in the completion of the work. Upon completion of the work defined in this contract CDI shall submit an invoice, including the assigned Nlets Purchase Order Number, to Nlets at 1918 W. Whispering Wind Drive, Phoenix, AZ 85085, Attention: Accounting Department, or via email to accounting@nlets.org, with a copy to the Nlets Project Manager. The invoice shall be accompanied by written certification from the California Department of Justice that all work described in Attachment A was completed in a satisfactory manner to the state. Invoices submitted will be paid on Terms NET30.

3. **TERM:**

This Agreement shall not become effective until approved by Nlets, and is effective from the date of execution to June 30, 2015, with the exception of CDI's obligation to provide warranty, maintenance and support for one year following project completion and acceptance. Work hours shall be determined by CDI to provide contracted services as soon as possible.

4. **TERMINATION:**

This Agreement may be terminated without cause by either of the parties upon written notice delivered to the other party at least ten working days prior to the intended date of termination. By such termination, neither party may nullify obligations already incurred for performance or failure to perform before the date of termination. Said contract will terminate June 30, 2015, with the exception of CDI's obligation to provide warranty, maintenance and support for one year following project completion and acceptance.

5. **STATUS OF CONTRACTOR:**

CDI shall be considered an independent contractor performing professional services for Nlets and is not an employee of Nlets. CDI shall not accrue leave, retirement, insurance bonding, use of Nlets vehicles, or any benefit afforded to employees of Nlets as a result of this Agreement.

6. **ASSIGNMENT:**

CDI shall not assign or transfer any interest in this Agreement or assign any

Nlets Contract No. _____

Nlets Initial _____

CDI Initial *dy*

claims for money due or to become due under this Agreement without prior written approval by Nlets.

7. SUBCONTRACTING:

CDI shall not subcontract any portion of the services performed under this Agreement without prior written approval of Nlets.

8. RECORDS AND AUDIT:

CDI shall maintain detailed time records which indicate the date, time and nature of services rendered. These records shall be subject to inspection by Nlets. Nlets shall have the right to audit billings both before and after payment under this Agreement.

9. RELEASE:

CDI, upon final payment of the amount due under this Agreement, releases Nlets and its employees from all liabilities, claims, and obligations whatsoever arising from or under this Agreement. CDI agrees not to propose or bind Nlets to any obligation not assumed herein by Nlets unless CDI has express written authority of Nlets to do so, and then only within the strict limits of that authority.

10. CONFIDENTIALITY:

Any information given to or developed by CDI in the performance of this Agreement shall be kept confidential and shall not be made available to any individual or organization by CDI without prior written approval of Nlets.

11. WARRANTY:

CDI warrants that (1) it has the appropriate knowledge and skill to perform the agreed services; and (2) it will use commercially reasonable efforts to provide the services on a timely basis and in the manner described.

12. WORK PRODUCT COPYRIGHT:

All written documentation material developed or acquired by CDI under this Agreement shall become the property of Nlets and shall be delivered to Nlets not later than the termination date of this Agreement.

13. CONFLICT OF INTEREST:

CDI warrants that it currently has no interest and shall not acquire any interest direct or indirect, which would conflict in any manner or degree with the performance of services required under this Agreement.

14. PROHIBITION AGAINST DUAL COMPENSATION:

Nlets Contract No. _____

Nlets Initial _____

CDI Initial *dy*

The charges for services rendered under this Agreement are reimbursable or subject to compensation only to the extent that such services relate exclusively and directly to the purpose of this Agreement and supplemental or additional payment for such services is not received by CDI from any other source.

15. **EQUAL EMPLOYMENT OPPORTUNITY:**
CDI, in the performance of this Agreement, shall not discriminate against any employee, client or other person on the basis of race, color, religion, national origin, sex or age.
16. **SCOPE OF AGREEMENT:**
This Agreement incorporates all the agreements, covenants, and understandings between the parties concerning the subject matter of the Agreement, and all such covenants, agreements and understandings are merged into this written Agreement. No prior agreement or understanding, verbal or otherwise, of the parties or their agents shall be valid or enforceable unless embodied in the Agreement.
17. **OMB CIRCULAR A-110 (SINGLE AUDIT REQUIREMENTS)**
All contract provisions set forth in Appendix A are hereby incorporated into this Agreement by reference. The provisions include, but are not limited to, compliance with the Equal Employment Opportunity Act; Anti-Kickback Act, Davis-Bacon Act; Contract Work Hours and Safety Standards Act; Rights to inventions made under a contract or agreement; Clean Air Act and Federal Water Pollution Control Act; Anti-Lobbying; and Debarment and suspension. Consultant affirms its familiarity with the provisions and agrees to comply with all such provisions as if those provisions were separately set forth herein.
18. **AMENDMENT:**
This Agreement shall not be altered, changed or amended except by instrument in writing executed by the parties to the Agreement.
19. **APPLICABLE LAW:**
This Agreement shall be governed by the applicable laws, statutes, rules and regulations of the State of Arizona.
20. **EFFECTIVE DATE:**
This Agreement is effective on the date specified in Paragraph 3 of this Agreement, or upon the date executed by all parties, whichever is later.

Nlets Contract No. _____

Nlets Initial _____
CDI Initial dy

Executed by the parties on the dates indicated:

NLETS, THE INTERNATIONAL JUSTICE & PUBLIC SAFETY NETWORK

By: _____

DATE: _____

Steven E. Correll, Executive Director

COMPUTER DEDUCTOIN, Inc.

By: Donald G. Foulk

DATE: 12/31/2014

Donald G. Foulk, Vice President
FEIN # 94-2147133

Nlets Contract No. _____

Nlets Initial _____

CDI Initial *dy*

ATTACHMENT A:

California Department of Justice

CLETS

Statement of Work

For Participation

In the NLETS XML DL Photo Retrieval Project

~~ Provided By ~~

Computer Deductions Inc.

December 2014

Nlets Contract No. _____

Nlets Initial _____

CDI Initial *dy*

Table of Contents

14. PROHIBITION AGAINST DUAL COMPENSATION:	3
15. EQUAL EMPLOYMENT OPPORTUNITY:	4
1 CLETS ENVIRONMENT	8
2 CDI PARTICIPATION	8
2.1 Assumptions	8
3 RESPONSIBILITIES	10
4 PRICING	11

Nlets Contract No. _____

Nlets Initial _____

CDI Initial *dy*

1 CLETS Environment

The California Law Enforcement Telecommunications System (CLETS) is the state's message switch for the exchange of Law Enforcement data among California (local, county and state level) users and systems (e.g. ACHS and DMV); and external national and international users and systems via NCIC and NLETS.

- An XML based interface header structure designed to exchange legacy and XML message payloads is currently used between CLETS and California's New CJIS Control (NCC).
- CDI supported the successful implementation of a NIEM XML interface for the exchange of Criminal Rapsheets between California and other states via NLETS (CHIEF Project).

California DOJ is positioned to support a transition to XML based message formatting. The NLETS XML DL Photo Retrieval Project is a logical step in XML's implementation.

2 CDI Participation

Computer Deductions, Inc. (CDI) is California's vendor who developed the California Law Enforcement Telecommunications System (CLETS). CLETS is the state's interface to NCIC, NLETS, California state systems (e.g. SVS and DMV), and California law enforcement users.

This proposal is to contract CDI's services to provide the CLETS level XML specifications and testing support required of California to achieve a NLETS Photo Retrieval Project implementation for SmartJustice users.

2.1 Assumptions

California desires to participate in the NLETS DL Photo Retrieval project using the National Information Exchange Model (NIEM) format for exchanging computerized Driver License data between NLETS and the CA DOJ. For CA DOJ, CLETS is a key architectural component to this effort.

Nlets Contract No. _____

Nlets Initial _____
 CDI Initial *dyf*

The following Data flow diagram depicts the CLETS architectural position role in the processing of the DL Photo Retrieval Project message keys from the perspective of California requests for out-of-state DMV driver license photos.

CA DQ DMV Queries to Other States

December 2014

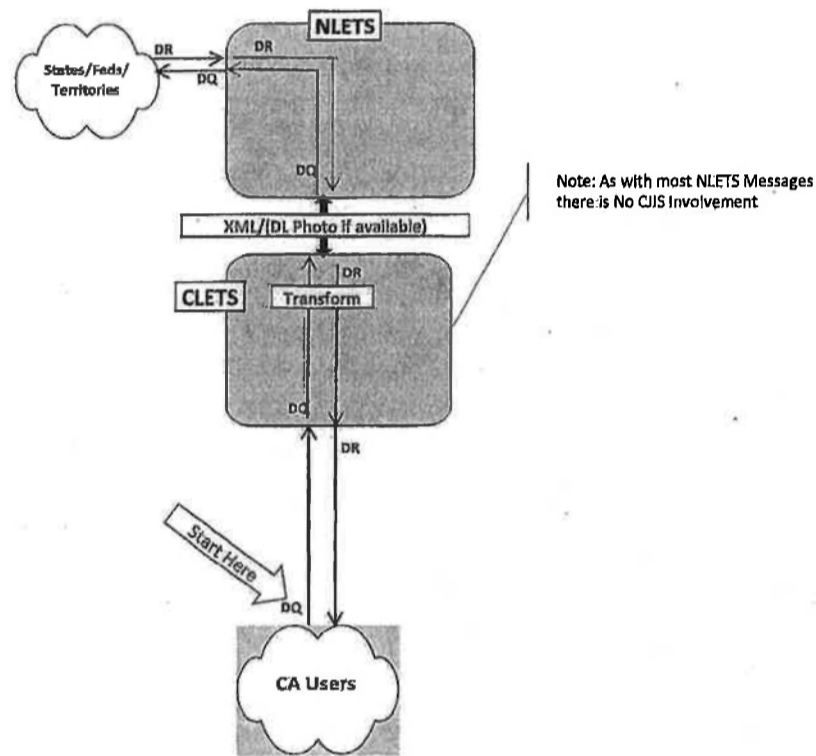

Assumptions/Description of Scope	Who is responsible
1. Within California, photos can only be retrieved via California's SmartJustice users.	NLETS/CLETS
2. SmartJustice DQ queries to out of state DMVs are received in JSON format. CLETS transforms these queries to Legacy format prior to sending them to NLETS.	NLETS/CLETS
3. All DR responses from NLETS are returned in NLETS NIEM format. CLETS uses NLETS provided style sheets (XLSX) to transform text content to its equivalent Legacy format prior its delivery. Photo content is extracted and forwarded to its SmartJustice user within a JSON structure.	NLETS/CLETS

Nlets Contract No. _____

Nlets Initial _____
CDI Initial *dg*

3 Responsibilities

Each of the participating parties (CDI, NLETS and California DOJ) involved in this project will have certain responsibilities as described below:

NLETS Responsibilities:

- Provide project management and coordination including monitoring project progress
- Provide (and maintain) DQ & DR interface and format requirements
- Identify non-California test cases and coordinate access to test systems
- Provide coordination of activity related to problem reporting and resolution
- Coordinate with CA DOJ (& CDI, as needed) for production implement and support

CDI CLETS Specific Responsibilities:

- Identify the DQ and DR message format requirements
- Obtain and validate the XSLT stylesheets from NLETS, correct and approve
- Document the testing message instances
- Provide CA DOJ with project task list
- Generate project plan, review and adhere to plan
- Provide project management and coordination including monitoring project progress
- Support CLETS unit and integration level testing
- Coordinate system testing with NLETS and CA DOJ
- Track CLETS specific testing, requested corrections and retesting, as needed
- Provide ongoing support post-implementation

California DOJ Responsibilities:

- Provide support for the system environment to insure proper testing, operation and readiness
- Provide network connections to internal and external systems
- Provide remote access to the required CLETS DOJ User Systems, e.g., SmartJustice
- Coordinate system testing in cooperation with NLETS and other CA DOJ team participants
- Approve requirements
- Document requirements
- Coordinate software development and testing
- Coordinate and approve Acceptance
- Coordinate and approve Implementation

Nlets Contract No. _____

Nlets Initial _____
CDI Initial *daf*

4 Pricing

The following table presents the pricing associated with the tasks for this statement of work. In order for CDI to deliver the working software in the required time frames, all parties must work closely together to insure that all required facilities are provided in a timely manner.

Description	Cost	Quantity	Total
Validate XSLT style sheets from NLETS for following transformations: <ul style="list-style-type: none">• DQ JSON and Legacy to XML• DR XML to JSON and Legacy	\$10,000.00	1	\$10,000.00
Define Test Instances <ul style="list-style-type: none">• In State Requests to Other States (DQ and DR)	\$10,000.00	1	\$10,000.00
Define CLETS and SmartJustice components of NLETS DL Photo Retrieval Project Acceptance Test Plan	\$10,000.00	1	\$10,000.00
Project Management, testing, support, and documentation	\$10,000.00	1	\$10,000.00
One (1) year warranty, maintenance and support	Included	1	Included
Total Cost			\$40,000.00

NOTE: Warranty shall commence after 10 days of production operation and included in existing CLETS maintenance contract.

Kirk Beardwood

From: Ted Rainer <trainer@nlets.org>
Sent: Tuesday, February 03, 2015 6:44 PM
To: Nancy Mar
Cc: Andrea BanuelosDavis; Kirk Beardwood; Richele Coy; Diana LaRue
Subject: Re: NLETS Reimbursement for CLETS Storage MOU 1 29 15.docx

Nancy: Yes. I am awaiting an internal meeting to discuss with the Nlets Financial group. I'll keep Andrea posted.

Thank you. Ted.

On Feb 3, 2015, at 9:42 PM, Nancy Mar <Nancy.Mar@doj.ca.gov> wrote:

Ted, I'll be on vacation. You can finalize the MOU with Andrea.

Thanks.

-Nancy Mar, Manager (I will be on vacation starting 2/4/15, returning on 2/17/15)
Department of Justice
IT Contracts and Procurement Unit (ITCPU)
4949 Broadway, Room D232
Sacramento, CA 95820
Nancy.mar@doj.ca.gov
(916) 227-3110 work
(916) 870-3815 mobile
Work hours: M-F 9:00 AM-5:30 PM

From: Ted Rainer [mailto:trainer@nlets.org]
Sent: Thursday, January 29, 2015 6:19 PM
To: Nancy Mar
Cc: Kirk Beardwood; Richele Coy; Diana LaRue; Andrea BanuelosDavis
Subject: Re: NLETS Reimbursement for CLETS Storage MOU 1 29 15.docx

Nancy: Thank you. I will review with the Nlets team tomorrow. Ted.

On Jan 29, 2015, at 4:50 PM, Nancy Mar <Nancy.Mar@doj.ca.gov> wrote:

Kirk and Ted,

For your review and comments.

Thanks.

-Nancy Mar, Manager

Department of Justice
IT Contracts and Procurement Unit (ITCPU)
4949 Broadway, Room D232
Sacramento, CA 95820
Nancy.mar@doj.ca.gov
(916) 227-3110 work
(916) 870-3815 mobile
Work hours: M-F 8:45 AM-5:15 PM

CONFIDENTIALITY NOTICE: This communication with its contents may contain confidential and/or legally privileged information. It is solely for the use of the intended recipient(s). Unauthorized interception, review, use or disclosure is prohibited and may violate applicable laws including the Electronic Communications Privacy Act. If you are not the intended recipient, please contact the sender and destroy all copies of the communication. <NLETS Reimbursement for CLETS Storage MOU 1 29 15.docx>

CONFIDENTIALITY NOTICE: This communication with its contents may contain confidential and/or legally privileged information. It is solely for the use of the intended recipient(s). Unauthorized interception, review, use or disclosure is prohibited and may violate applicable laws including the Electronic Communications Privacy Act. If you are not the intended recipient, please contact the sender and destroy all copies of the communication.



California Department of Justice
California Justice Information Services Division
and
The International Justice and Public Safety Network

MEMORANDUM OF UNDERSTANDING

The California Department of Justice, California Justice Information Services Division, herein referred to as CJIS, has obtained funding from The International Justice & Public Safety Network, herein referred to as NLETS, a non-profit organization.

PURPOSE

Obtaining the funds will allow CJIS to purchase additional Centera storage for the California Law Enforcement Telecommunications System (CLETS).

CJIS is currently establishing the infrastructure needed to electronically receive Driver License Photos from out-of-state via NLETS. The additional storage will permit CJIS to store the out-of-state Driver License photos. In addition, per CJIS policies, CJIS is required to store all CLETS data (e.g. photos) for 37 months. The additional storage will help CJIS meet this mandate.

TERM OF AGREEMENT

This Agreement is for one-time funding effective upon receipt of all approvals.

FUNDING AMOUNT

The amount funded will be \$10,000.00.

PAYMENT METHOD

NLETS agrees to fund CJIS upon receipt of a DOJ invoice. Upon approval of this document, CJIS will expense the NLETS payment by posting the invoice against Cost Code 870.0.

PRIMARY CONTACTS

NLETS

Ted Rainer (Project Manager)
1918 W. Whispering Wind Drive, Phoenix, AZ 85085
Ph: (623) 308-3547
e-Mail: accounting@nlets.org

Department of Justice

Kirk Beardwood (CSSS Manager)
4949 Broadway
Sacramento, CA 95820
Ph: (916) 227-3985
e-Mail: Kirk.Beardwood@doj.ca.gov

Joe Adkins (SAN Manager)
4949 Broadway
Sacramento, CA 95820
Ph: (916) 227-7445
e-Mail: joe.adkins@doj.ca.gov

SIGNATURE APPROVALS

IN WITNESS WHEREOF, the parties hereto have executed this Agreement on the day and year as indicated:

NLETS

Department of Justice

By: _____
Steve Correll, Director

By: _____
Kirk Beardwood, CSSS Manager

Date: _____

Date: _____

Kirk Beardwood

From: Nancy Mar
Sent: Friday, January 09, 2015 10:09 AM
To: Kirk Beardwood
Cc: Andrea BanuelosDavis
Subject: FW: NLETS MOU for CLETS Centera Storage Funds

Can you get the approval email from Julie too?

From: Ted Rainer [mailto:trainer@nlets.org]
Sent: Friday, January 09, 2015 9:27 AM
To: Nancy Mar
Cc: Andrea BanuelosDavis; Richele Coy
Subject: Re: NLETS MOU for CLETS Centera Storage Funds

Nancy: Thank you for working with me to get CA the required funding for the storage hardware.

I had a quick thought, you probably should get the BAF approval e-mail from Julie since she is the Nlets rep. As a reminder to her, the acceptance e-mail was sent on 12/15. If she cannot find it, I can provide.

Thank you, Ted.

On Jan 9, 2015, at 11:42 AM, Nancy Mar <Nancy.Mar@doj.ca.gov> wrote:

Ted,

Just tried to call you. Please call us back at your earliest convenience. 916 227-3110

Thanks.

-Nancy Mar, Manager
Department of Justice
IT Contracts and Procurement Unit (ITCPU)
4949 Broadway, Room D232
Sacramento, CA 95820
Nancy.mar@doj.ca.gov
(916) 227-3110 work
(916) 870-3815 mobile
Work hours: M-F 8:45 AM-5:15 PM

From: Ted Rainer [mailto:trainer@nlets.org]
Sent: Friday, January 09, 2015 7:42 AM
To: Andrea BanuelosDavis
Cc: Nancy Mar; Richele Coy
Subject: Re: NLETS MOU for CLETS Centera Storage Funds

Andrea: Thank you for the prompt reply. I just left you a v-mail. Pretty much any time except from 8:00-8:30 your time. Ted.

On Jan 9, 2015, at 10:36 AM, Andrea BanuelosDavis <Andrea.BanuelosDavis@doj.ca.gov> wrote:

Yes, please let me know what time works for you.

From: Ted Rainer [mailto:trainer@nlets.org]
Sent: Thursday, January 08, 2015 6:24 PM
To: Andrea BanuelosDavis
Cc: Nancy Mar; Richele Coy
Subject: Re: NLETS MOU for CLETS Centera Storage Funds

Andrea: I think there may have been a mis-communication here. Will you be available for a call tomorrow (Friday) so I can explain my concerns.

Thank you, Ted.
623-308-3547

On Jan 8, 2015, at 2:27 PM, Andrea BanuelosDavis <Andrea.BanuelosDavis@doj.ca.gov> wrote:

Hi Ted,

Per my voice mail, Kirk Beardwood has requested we work with NLETS to create a Memorandum of Understanding (MOU) to obtain funds to purchase additional CLETS Centera storage. Could you please draft the MOU and send to me for review?

Andrea Banuelos-Davis
Department of Justice
Information Technology Contracts and Procurement Unit
4949 Broadway, D-232
Sacramento, CA 95820
(916) 227-3195

CONFIDENTIALITY NOTICE: This communication with its contents may contain confidential and/or legally privileged information. It is solely for the use of the intended recipient(s). Unauthorized interception, review, use or disclosure is prohibited and may violate applicable laws including the Electronic Communications Privacy Act. If you are not the intended recipient, please contact the sender and destroy all copies of the communication.

CONFIDENTIALITY NOTICE: This communication with its contents may contain confidential and/or legally privileged information. It is solely for the use of the intended recipient(s). Unauthorized interception, review, use or disclosure is prohibited and may violate applicable laws including the Electronic Communications Privacy Act. If you are not

the intended recipient, please contact the sender and destroy all copies of the communication.

CONFIDENTIALITY NOTICE: This communication with its contents may contain confidential and/or legally privileged information. It is solely for the use of the intended recipient(s). Unauthorized interception, review, use or disclosure is prohibited and may violate applicable laws including the Electronic Communications Privacy Act. If you are not the intended recipient, please contact the sender and destroy all copies of the communication.

Kirk Beardwood

From: Nancy Mar
Sent: Friday, January 09, 2015 9:00 AM
To: Kirk Beardwood
Cc: Andrea BanuelosDavis
Subject: RE: NLETS Photo Sharing - DQ Message

Kirk,

Can I get a copy of the \$50,000 Brodie Assistance Fund (BAF) application that was signed by Julie Basco.

Thanks.

-Nancy Mar, Manager
Department of Justice
IT Contracts and Procurement Unit (ITCPU)
4949 Broadway, Room D232
Sacramento, CA 95820
Nancy.mar@doj.ca.gov
(916) 227-3110 work
(916) 870-3815 mobile
Work hours: M-F 8:45 AM-5:15 PM

From: Kirk Beardwood
Sent: Wednesday, January 07, 2015 11:25 AM
To: Ted Rainer; Nancy Mar
Subject: RE: NLETS Photo Sharing - DQ Message

Ted,

I have spoken with our Contracts Unit, and I am adding Nancy to my reply. Nancy will be addressing the hardware portion of the contract. I included the CDI contract for Nancy's benefit.

Nancy Mar
(916) 227-3110

Thanks,
Kirk

From: Ted Rainer [<mailto:trainer@nlets.org>]
Sent: Monday, January 05, 2015 1:13 PM
To: Kirk Beardwood
Subject: Re: NLETS Photo Sharing - DQ Message

Kirk; Any thoughts on the hardware side. I'd like to get that nailed down (or at least a probable solution) before I submit the CDI contract for Nlets approval.

Begin forwarded message:

From: Ted Rainer <trainer@nlets.org>
Date: December 31, 2014 at 8:29:08 AM PST
To: Kirk Beardwood <Kirk.Beardwood@doj.ca.gov>
Subject: Re: NLETS Photo Sharing - DQ Message

Kirk: Here is a PDF of the CDI contract with all changes updated. Please have CDI sign page 5 and initial each page in the upper right hand corner (next to CDI Initial). Scan and return to me. I will submit to the Nlets procurement process. This will result in an executed copy and PO which I will return to you for delivery to CDI.

Thank you and have a great New Year. Ted.

CONFIDENTIALITY NOTICE: This communication with its contents may contain confidential and/or legally privileged information. It is solely for the use of the intended recipient(s). Unauthorized interception, review, use or disclosure is prohibited and may violate applicable laws including the Electronic Communications Privacy Act. If you are not the intended recipient, please contact the sender and destroy all copies of the communication. <NLETS Photo PO CDI Signed.pdf>

Julie Basco

From: Bonnie Locke <blocke@nlets.org>
Sent: Wednesday, November 19, 2014 11:38 AM
To: Julie Basco
Subject: Touch Base - CA
Attachments: DLPhotos.pdf; CorrectionsPhotos.pdf; TIPSStates.pdf
Importance: High

Hi Julie!

How are you??

As we near the end of the year, I have been making a push to spend remaining BAF funds. I was going through our website and running some of the maps to see what projects States have gone live with – in particular DL photos, Corrections photos and TIPS.

As you know, I have BAF funds to implement all of these. I am encouraging Reps to submit their requests before the deadline of Dec 12, 2014.

It has been a while since we have talked. Is there anything I can be doing to support you more?

Are you interested in some training? Teri is more than willing to come out there.

BTW, I met your new Homeland Security person – Caroline? She is delightful.

Anyway, let me know your thoughts or I can call you as well.....thanks!

Bonnie

Bonnie Locke

Nlets Director of Business Development

Office: (623) 308-3504 | Fax: (623) 308-3501
1918 W. Whispering Wind Dr. | Phoenix, AZ 85085
blocke@nlets.org | www.nlets.org

Nlets - the International Justice and Public Safety Network



NISP - DL Photo Sharing

Nlets Service Map - created on November 3, 2014

■ Implemented

▣ Upcoming States
Expected to implement this quarter.

▨ Receiving DL Photos

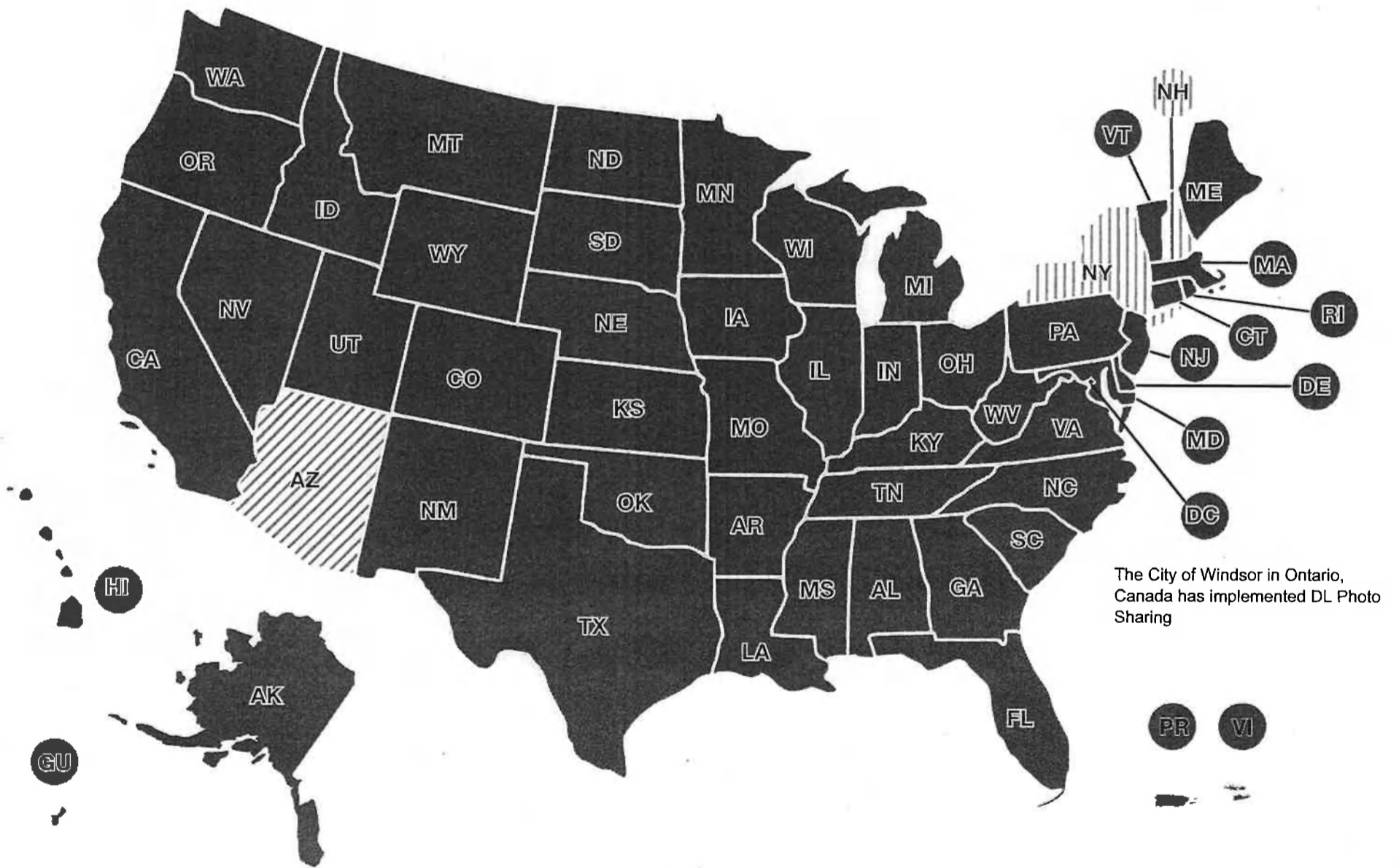



NISP - DL Photo Sharing

Nlets Service Map - created on November 3, 2014

■ Implemented

☑ Upcoming States
Expected to implement this quarter.

▣ Receiving DL Photos



The City of Windsor in Ontario, Canada has implemented DL Photo Sharing

Nlets NCIEN - Corrections Photo Sharing
Nlets Service Map - created on October 16, 2014

■ Implemented



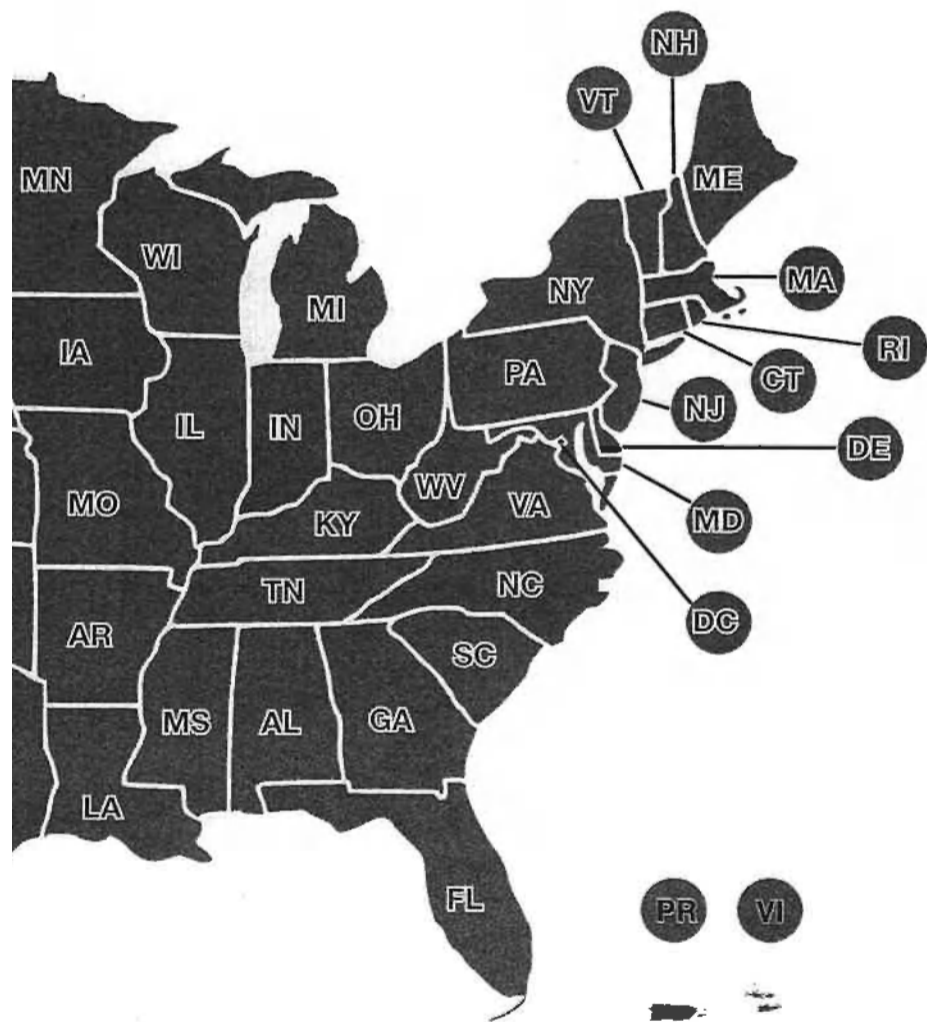

Julie Basco

From: Bonnie Locke <blocke@nlets.org>
Sent: Friday, November 21, 2014 1:05 PM
To: Kate Silhol
Cc: Julie Basco
Subject: DL Photo Sharing in CA

Importance: High

Hi Kate,

I have some potentially good news. Julie is going to talk with her contract programmers to see what it would take to potentially do the programming to be able to RECEIVE DL images from out of state.

She asked about image size and any specifications she should share with her staff. Could you possibly provide anything she might need? I started to point her to the WIKI but wanted to be sure she has the right information.

Thanks!
Bonnie

Bonnie Locke
Nlets Director of Business Development

Office: (623) 308-3504 | Fax: (623) 308-3501
1918 W. Whispering Wind Dr. | Phoenix, AZ 85085
blocke@nlets.org | www.nlets.org

Nlets - the International Justice and Public Safety Network

Julie Basco

From: Bonnie Locke <blocke@nlets.org>
Sent: Tuesday, December 02, 2014 8:59 AM
To: Julie Basco
Subject: BAF to receive DL Photos - deadline to submit Dec 12
Attachments: BAF Application.pdf

Importance: High

Hi Julie!

How did the conversation go with your programmers? Anything I can do to help?

From: Kate Silhol
Sent: Friday, November 21, 2014 3:11 PM
To: Bonnie Locke
Cc: Rep - CA - Basco, Julie
Subject: RE: DL Photo Sharing in CA

Sure thing. Hi Julie, essentially, when you send a request, you'll need to indicate that a photo is being requested via the IMQ/ tag or its XML equivalent. In order to receive images in the responses, you'll need to be set up for XML for DRs. The XML DR will contain an element with a Base64 encoded image. The images are generally around 25k and that's what we ask states to aim for although I have occasionally seen larger (40k) images. The wiki is the best spot for some initial documents and I can provide you the schemas if you know which version of XML you'll be implementing (GJXDM or NIEM). Please let me know if you have any other questions. Thanks,

Kate Silhol
Nlets Lead Software Engineer

Office: (623) 308-3511 | Fax: (623) 308-3501
1918 W. Whispering Wind Drive | Phoenix, AZ 85085
ksilhol@nlets.org | www.nlets.org

Nlets - the International Justice and Public Safety Network

From: Bonnie Locke
Sent: Friday, November 21, 2014 2:05 PM
To: Kate Silhol
Cc: Rep - CA - Basco, Julie
Subject: DL Photo Sharing in CA
Importance: High

Hi Kate,

I have some potentially good news. Julie is going to talk with her contract programmers to see what it would take to potentially do the programming to be able to RECEIVE DL images from out of state.

She asked about image size and any specifications she should share with her staff. Could you possibly provide anything she might need? I started to point her to the WIKI but wanted to be sure she has the right information.

Thanks!
Bonnie

Bonnie Locke
Nlets Director of Business Development

Office: (623) 308-3504 | Fax: (623) 308-3501
1918 W. Whispering Wind Dr. | Phoenix, AZ 85085
blocke@nlets.org | www.nlets.org

Nlets - the International Justice and Public Safety Network

Nlets Brodie Assistance Fund Application

Print Form

All fields must be must be completed or application will be denied - email completed form to blocke@nlets.org

Applicant Information

Name: Are you the Appointed Nlets Rep?: Date:
Email: Organization: Phone #:

Purpose Of Request

Type: Date(s): Location:
Event/Project Name & Description:

Expenses

Event/Project Cost:	<input type="text"/>	Airfare:	<input type="text"/>		
Ground Transportation:	<input type="text"/>	# of Days:	<input type="text"/>	Transportation Total:	<input type="text"/>
Parking:	<input type="text"/>	# of Days:	<input type="text"/>	Parking Total:	<input type="text"/>
Lodging Per Night:	<input type="text"/>	# of Nights:	<input type="text"/>	Lodging Total:	<input type="text"/>
Daily Per Diem:	<input type="text"/>	# of Days:	<input type="text"/>	Per Diem Total:	<input type="text"/>
				Total expenses:	<input type="text"/>
				# Of Attendees Applied for:	<input type="text"/>
				Total Amount Requested:	<input type="text"/>

Name(s) of attendee(s)

THIS CERTIFICATION MANDATORY - Forms submitted without this box checked will be denied: By checking this box, I certify all financial avenues within the State have been exhausted; without BAF approval, there is no other way to fund this project/training.

Justification for request (minimum 500 words) Indicate problem statement and proposed solution. Use additional supporting documentation if necessary.

Return completed form to:
blocke@nlets.org

Nlets Staff Use Only - Status & Comments

Received Date: Comments, Notes, Name of Person Taking Action:
Approved?: YES NO

Julie Basco

From: Bonnie Locke <blocke@nlets.org>
Sent: Tuesday, December 02, 2014 6:15 PM
To: Julie Basco
Cc: Kate Silhol
Subject: Re: BAF to receive DL Photos - deadline to submit Dec 12

Not sure.

On Dec 2, 2014, at 7:25 PM, Julie Basco <Julie.Basco@doi.ca.gov> wrote:

Did someone (Kirk Beardwood) call Kate?

From: Bonnie Locke [<mailto:blocke@nlets.org>]
Sent: Tuesday, December 02, 2014 8:59 AM
To: Julie Basco
Subject: BAF to receive DL Photos - deadline to submit Dec 12
Importance: High

Hi Julie!

How did the conversation go with your programmers? Anything I can do to help?

From: Kate Silhol
Sent: Friday, November 21, 2014 3:11 PM
To: Bonnie Locke
Cc: Rep - CA - Basco, Julie
Subject: RE: DL Photo Sharing in CA

Sure thing. Hi Julie, essentially, when you send a request, you'll need to indicate that a photo is being requested via the IMQ/ tag or its XML equivalent. In order to receive images in the responses, you'll need to be set up for XML for DRs. The XML DR will contain an element with a Base64 encoded image. The images are generally around 25k and that's what we ask states to aim for although I have occasionally seen larger (40k) images. The wiki is the best spot for some initial documents and I can provide you the schemas if you know which version of XML you'll be implementing (GJXDM or NIEM). Please let me know if you have any other questions. Thanks,

Kate Silhol
Nlets Lead Software Engineer

Office: (623) 308-3511 | Fax: (623) 308-3501
1918 W. Whispering Wind Drive | Phoenix, AZ 85085

ksilhol@nlets.org | www.nlets.org

Nlets - the International Justice and Public Safety Network

From: Bonnie Locke
Sent: Friday, November 21, 2014 2:05 PM
To: Kate Silhol
Cc: Rep - CA - Basco, Julie
Subject: DL Photo Sharing in CA
Importance: High

Hi Kate,

I have some potentially good news. Julie is going to talk with her contract programmers to see what it would take to potentially do the programming to be able to RECEIVE DL images from out of state.

She asked about image size and any specifications she should share with her staff. Could you possibly provide anything she might need? I started to point her to the WIKI but wanted to be sure she has the right information.

Thanks!
Bonnie

Bonnie Locke
Nlets Director of Business Development

Office: (623) 308-3504 | Fax: (623) 308-3501
1918 W. Whispering Wind Dr. | Phoenix, AZ 85085
blocke@nlets.org | www.nlets.org

Nlets - the International Justice and Public Safety Network

CONFIDENTIALITY NOTICE: This communication with its contents may contain confidential and/or legally privileged information. It is solely for the use of the intended recipient(s). Unauthorized interception, review, use or disclosure is prohibited and may violate applicable laws including the Electronic Communications Privacy Act. If you are not the intended recipient, please contact the sender and destroy all copies of the communication.

Julie Basco

From: Bonnie Locke <blocke@nlets.org>
Sent: Wednesday, December 03, 2014 7:59 AM
To: Julie Basco
Cc: Kate Silhol
Subject: RE: BAF to receive DL Photos - deadline to submit Dec 12

Importance: High

Hi Julie.

Kate has not heard from anyone. If you want to provide contact information she can try to reach him as well?

Thanks,
Bonnie

Bonnie Locke

Nlets Director of Business Development

Office: (623) 308-3504 | Fax: (623) 308-3501
1918 W. Whispering Wind Dr. | Phoenix, AZ 85085
blocke@nlets.org | www.nlets.org

Nlets - the International Justice and Public Safety Network

From: Julie Basco [<mailto:Julie.Basco@doj.ca.gov>]
Sent: Tuesday, December 2, 2014 7:25 PM
To: Bonnie Locke
Subject: RE: BAF to receive DL Photos - deadline to submit Dec 12

Did someone (Kirk Beardwood) call Kate?

From: Bonnie Locke [<mailto:blocke@nlets.org>]
Sent: Tuesday, December 02, 2014 8:59 AM
To: Julie Basco

Subject: BAF to receive DL Photos - deadline to submit Dec 12
Importance: High

Hi Julie!

How did the conversation go with your programmers? Anything I can do to help?

From: Kate Silhol
Sent: Friday, November 21, 2014 3:11 PM
To: Bonnie Locke
Cc: Rep - CA - Basco, Julie
Subject: RE: DL Photo Sharing in CA

Sure thing. Hi Julie, essentially, when you send a request, you'll need to indicate that a photo is being requested via the IMQ/ tag or its XML equivalent. In order to receive images in the responses, you'll need to be set up for XML for DRs. The XML DR will contain an element with a Base64 encoded image. The images are generally around 25k and that's what we ask states to aim for although I have occasionally seen larger (40k) images. The wiki is the best spot for some initial documents and I can provide you the schemas if you know which version of XML you'll be implementing (GJXDM or NIEM). Please let me know if you have any other questions. Thanks,

Kate Silhol
Nlets Lead Software Engineer

Office: (623) 308-3511 | Fax: (623) 308-3501
1918 W. Whispering Wind Drive | Phoenix, AZ 85085
ksilhol@nlets.org | www.nlets.org

Nlets - the International Justice and Public Safety Network

From: Bonnie Locke
Sent: Friday, November 21, 2014 2:05 PM
To: Kate Silhol
Cc: Rep - CA - Basco, Julie
Subject: DL Photo Sharing in CA
Importance: High

Hi Kate,

I have some potentially good news. Julie is going to talk with her contract programmers to see what it would take to potentially do the programming to be able to RECEIVE DL images from out of state.

She asked about image size and any specifications she should share with her staff. Could you possibly provide anything she might need? I started to point her to the WIKI but wanted to be sure she has the right information.

Thanks!
Bonnie

Bonnie Locke
Nlets Director of Business Development

Office: (623) 308-3504 | Fax: (623) 308-3501
1918 W. Whispering Wind Dr. | Phoenix, AZ 85085
blocke@nlets.org | www.nlets.org

Nlets - the International Justice and Public Safety Network

CONFIDENTIALITY NOTICE: This communication with its contents may contain confidential and/or legally privileged information. It is solely for the use of the intended recipient(s). Unauthorized interception, review, use or disclosure is prohibited and may violate applicable laws including the Electronic Communications Privacy Act. If you are not the intended recipient, please contact the sender and destroy all copies of the communication.

Julie Basco

From: Bonnie Locke <blocke@nlets.org>
Sent: Thursday, December 04, 2014 12:33 PM
To: Julie Basco
Subject: FW: BAF to receive DL Photos - deadline to submit Dec 12

YAY!!

Bonnie Locke

Nlets Director of Business Development

Office: (623) 308-3504 | Fax: (623) 308-3501
1918 W. Whispering Wind Dr. | Phoenix, AZ 85085
blocke@nlets.org | www.nlets.org

Nlets - the International Justice and Public Safety Network

From: Kate Silhol
Sent: Thursday, December 4, 2014 10:03 AM
To: Bonnie Locke
Subject: RE: BAF to receive DL Photos - deadline to submit Dec 12

Just wanted to let you know that I spoke with the CA technical team today and they seem ready to go. They asked me about funding and I said that you will work with Julie on that – hopefully that was the correct answer!

From: Bonnie Locke
Sent: Wednesday, December 3, 2014 8:59 AM
To: Rep - CA - Basco, Julie
Cc: Kate Silhol
Subject: RE: BAF to receive DL Photos - deadline to submit Dec 12
Importance: High

Hi Julie.

Kate has not heard from anyone. If you want to provide contact information she can try to reach him as well?

Thanks,

Bonnie

Bonnie Locke
Nlets Director of Business Development

Office: (623) 308-3504 | Fax: (623) 308-3501
1918 W. Whispering Wind Dr. | Phoenix, AZ 85085
blocke@nlets.org | www.nlets.org

Nlets - the International Justice and Public Safety Network

From: Julie Basco [<mailto:Julie.Basco@doj.ca.gov>]
Sent: Tuesday, December 2, 2014 7:25 PM
To: Bonnie Locke
Subject: RE: BAF to receive DL Photos - deadline to submit Dec 12

Did someone (Kirk Beardwood) call Kate?

From: Bonnie Locke [<mailto:blocke@nlets.org>]
Sent: Tuesday, December 02, 2014 8:59 AM
To: Julie Basco
Subject: BAF to receive DL Photos - deadline to submit Dec 12
Importance: High

Hi Julie!

How did the conversation go with your programmers? Anything I can do to help?

From: Kate Silhol
Sent: Friday, November 21, 2014 3:11 PM
To: Bonnie Locke
Cc: Rep - CA - Basco, Julie
Subject: RE: DL Photo Sharing in CA

Sure thing. Hi Julie, essentially, when you send a request, you'll need to indicate that a photo is being requested via the IMQ/ tag or its XML equivalent. In order to receive images in the responses, you'll need to be set up for XML for DRs. The XML DR will contain an element with a Base64 encoded image. The images are generally around 25k and that's what

we ask states to aim for although I have occasionally seen larger (40k) images. The wiki is the best spot for some initial documents and I can provide you the schemas if you know which version of XML you'll be implementing (GJXDM or NIEM). Please let me know if you have any other questions. Thanks,

Kate Silhol
Nlets Lead Software Engineer

Office: (623) 308-3511 | Fax: (623) 308-3501
1918 W. Whispering Wind Drive | Phoenix, AZ 85085
ksilhol@nlets.org | www.nlets.org

Nlets - the International Justice and Public Safety Network

From: Bonnie Locke
Sent: Friday, November 21, 2014 2:05 PM
To: Kate Silhol
Cc: Rep - CA - Basco, Julie
Subject: DL Photo Sharing in CA
Importance: High

Hi Kate,

I have some potentially good news. Julie is going to talk with her contract programmers to see what it would take to potentially do the programming to be able to RECEIVE DL images from out of state.

She asked about image size and any specifications she should share with her staff. Could you possibly provide anything she might need? I started to point her to the WIKI but wanted to be sure she has the right information.

Thanks!
Bonnie

Bonnie Locke
Nlets Director of Business Development

Office: (623) 308-3504 | Fax: (623) 308-3501
1918 W. Whispering Wind Dr. | Phoenix, AZ 85085
blocke@nlets.org | www.nlets.org

Nlets - the International Justice and Public Safety Network

CONFIDENTIALITY NOTICE: This communication with its contents may contain confidential and/or legally privileged information. It is solely for the use of the intended recipient(s). Unauthorized interception, review, use or disclosure is prohibited and may violate applicable laws including the Electronic Communications Privacy Act. If you are not the intended recipient, please contact the sender and destroy all copies of the communication.

Julie Basco

From: Bonnie Locke <blocke@nlets.org>
Sent: Monday, December 08, 2014 9:54 AM
To: Julie Basco
Subject: RE: BAF to receive DL Photos - deadline to submit Dec 12

Hi Julie – I am on my way to Phoenix for the rest of the week – call my cell if you need anything – 602-402-0056

Bonnie Locke
Nlets Director of Business Development

Office: (623) 308-3504 | Fax: (623) 308-3501
1918 W. Whispering Wind Dr. | Phoenix, AZ 85085
blocke@nlets.org | www.nlets.org

Nlets - the International Justice and Public Safety Network

From: Bonnie Locke
Sent: Thursday, December 4, 2014 2:33 PM
To: Rep - CA - Basco, Julie (julie.basco@doj.ca.gov)
Subject: FW: BAF to receive DL Photos - deadline to submit Dec 12

YAY!!

Bonnie Locke
Nlets Director of Business Development

Office: (623) 308-3504 | Fax: (623) 308-3501
1918 W. Whispering Wind Dr. | Phoenix, AZ 85085
blocke@nlets.org | www.nlets.org

Nlets - the International Justice and Public Safety Network

From: Kate Silhol
Sent: Thursday, December 4, 2014 10:03 AM
To: Bonnie Locke
Subject: RE: BAF to receive DL Photos - deadline to submit Dec 12

Just wanted to let you know that I spoke with the CA technical team today and they seem ready to go. They asked me about funding and I said that you will work with Julie on that – hopefully that was the correct answer!

From: Bonnie Locke
Sent: Wednesday, December 3, 2014 8:59 AM
To: Rep - CA - Basco, Julie
Cc: Kate Silhol
Subject: RE: BAF to receive DL Photos - deadline to submit Dec 12
Importance: High

Hi Julie.

Kate has not heard from anyone. If you want to provide contact information she can try to reach him as well?

Thanks,
Bonnie

Bonnie Locke
Nlets Director of Business Development

Office: (623) 308-3504 | Fax: (623) 308-3501
1918 W. Whispering Wind Dr. | Phoenix, AZ 85085
blocke@nlets.org | www.nlets.org

Nlets - the International Justice and Public Safety Network

From: Julie Basco [<mailto:Julie.Basco@doj.ca.gov>]
Sent: Tuesday, December 2, 2014 7:25 PM
To: Bonnie Locke
Subject: RE: BAF to receive DL Photos - deadline to submit Dec 12

Did someone (Kirk Beardwood) call Kate?

From: Bonnie Locke [<mailto:blocke@nlets.org>]
Sent: Tuesday, December 02, 2014 8:59 AM
To: Julie Basco
Subject: BAF to receive DL Photos - deadline to submit Dec 12
Importance: High

Hi Julie!

How did the conversation go with your programmers? Anything I can do to help?

From: Kate Silhol
Sent: Friday, November 21, 2014 3:11 PM
To: Bonnie Locke
Cc: Rep - CA - Basco, Julie
Subject: RE: DL Photo Sharing in CA

Sure thing. Hi Julie, essentially, when you send a request, you'll need to indicate that a photo is being requested via the IMQ/ tag or its XML equivalent. In order to receive images in the responses, you'll need to be set up for XML for DRs. The XML DR will contain an element with a Base64 encoded image. The images are generally around 25k and that's what we ask states to aim for although I have occasionally seen larger (40k) images. The wiki is the best spot for some initial documents and I can provide you the schemas if you know which version of XML you'll be implementing (GJXDM or NIEM). Please let me know if you have any other questions. Thanks,

Kate Silhol
Nlets Lead Software Engineer

Office: (623) 308-3511 | Fax: (623) 308-3501
1918 W. Whispering Wind Drive | Phoenix, AZ 85085
ksilhol@nlets.org | www.nlets.org

Nlets - the International Justice and Public Safety Network

From: Bonnie Locke
Sent: Friday, November 21, 2014 2:05 PM
To: Kate Silhol
Cc: Rep - CA - Basco, Julie
Subject: DL Photo Sharing in CA
Importance: High

Hi Kate,

I have some potentially good news. Julie is going to talk with her contract programmers to see what it would take to potentially do the programming to be able to RECEIVE DL images from out of state.

She asked about image size and any specifications she should share with her staff. Could you possibly provide anything she might need? I started to point her to the WIKI but wanted to be sure she has the right information.

Thanks!
Bonnie

Bonnie Locke

Nlets Director of Business Development

Office: (623) 308-3504 | Fax: (623) 308-3501
1918 W. Whispering Wind Dr. | Phoenix, AZ 85085
blocke@nlets.org | www.nlets.org

Nlets - the International Justice and Public Safety Network

CONFIDENTIALITY NOTICE: This communication with its contents may contain confidential and/or legally privileged information. It is solely for the use of the intended recipient(s). Unauthorized interception, review, use or disclosure is prohibited and may violate applicable laws including the Electronic Communications Privacy Act. If you are not the intended recipient, please contact the sender and destroy all copies of the communication.

Julie Basco

From: Bonnie Locke <blocke@nlets.org>
Sent: Monday, December 08, 2014 1:55 PM
To: Julie Basco
Subject: RE: BAF to receive DL Photos - deadline to submit Dec 12

Importance: High

Hi Julie – I am on a call just finishing up and will call but I will need an SOW from your vendor to attach to this.

Bonnie Locke

Nlets Director of Business Development

Office: (623) 308-3504 | Fax: (623) 308-3501
1918 W. Whispering Wind Dr. | Phoenix, AZ 85085
blocke@nlets.org | www.nlets.org

Nlets - the International Justice and Public Safety Network

From: Julie Basco [mailto:Julie.Basco@doj.ca.gov]
Sent: Monday, December 8, 2014 3:48 PM
To: Bonnie Locke
Subject: RE: BAF to receive DL Photos - deadline to submit Dec 12

From: Bonnie Locke [mailto:blocke@nlets.org]
Sent: Monday, December 08, 2014 9:54 AM
To: Julie Basco
Subject: RE: BAF to receive DL Photos - deadline to submit Dec 12

Hi Julie – I am on my way to Phoenix for the rest of the week – call my cell if you need anything – 602-402-0056

Bonnie Locke

Niets Director of Business Development

Office: (623) 308-3504 | Fax: (623) 308-3501
1918 W. Whispering Wind Dr. | Phoenix, AZ 85085
blocke@nlets.org | www.nlets.org

Niets - the International Justice and Public Safety Network

From: Bonnie Locke
Sent: Thursday, December 4, 2014 2:33 PM
To: Rep - CA - Basco, Julie (julie.basco@doj.ca.gov)
Subject: FW: BAF to receive DL Photos - deadline to submit Dec 12

YAY!!

Bonnie Locke

Niets Director of Business Development

Office: (623) 308-3504 | Fax: (623) 308-3501
1918 W. Whispering Wind Dr. | Phoenix, AZ 85085
blocke@nlets.org | www.nlets.org

Niets - the International Justice and Public Safety Network

From: Kate Silhol
Sent: Thursday, December 4, 2014 10:03 AM
To: Bonnie Locke
Subject: RE: BAF to receive DL Photos - deadline to submit Dec 12

Just wanted to let you know that I spoke with the CA technical team today and they seem ready to go. They asked me about funding and I said that you will work with Julie on that – hopefully that was the correct answer!

From: Bonnie Locke
Sent: Wednesday, December 3, 2014 8:59 AM
To: Rep - CA - Basco, Julie

Cc: Kate Silhol
Subject: RE: BAF to receive DL Photos - deadline to submit Dec 12
Importance: High

Hi Julie.

Kate has not heard from anyone. If you want to provide contact information she can try to reach him as well?

Thanks,
Bonnie

Bonnie Locke
Nlets Director of Business Development

Office: (623) 308-3504 | Fax: (623) 308-3501
1918 W. Whispering Wind Dr. | Phoenix, AZ 85085
blocke@nlets.org | www.nlets.org

Nlets - the International Justice and Public Safety Network

From: Julie Basco [<mailto:Julie.Basco@doj.ca.gov>]
Sent: Tuesday, December 2, 2014 7:25 PM
To: Bonnie Locke
Subject: RE: BAF to receive DL Photos - deadline to submit Dec 12

Did someone (Kirk Beardwood) call Kate?

From: Bonnie Locke [<mailto:blocke@nlets.org>]
Sent: Tuesday, December 02, 2014 8:59 AM
To: Julie Basco
Subject: BAF to receive DL Photos - deadline to submit Dec 12
Importance: High

Hi Julie!

How did the conversation go with your programmers? Anything I can do to help?

From: Kate Silhol
Sent: Friday, November 21, 2014 3:11 PM
To: Bonnie Locke
Cc: Rep - CA - Basco, Julie
Subject: RE: DL Photo Sharing in CA

Sure thing. Hi Julie, essentially, when you send a request, you'll need to indicate that a photo is being requested via the IMQ/ tag or its XML equivalent. In order to receive images in the responses, you'll need to be set up for XML for DRs. The XML DR will contain an element with a Base64 encoded image. The images are generally around 25k and that's what we ask states to aim for although I have occasionally seen larger (40k) images. The wiki is the best spot for some initial documents and I can provide you the schemas if you know which version of XML you'll be implementing (GJXDM or NIEM). Please let me know if you have any other questions. Thanks,

Kate Silhol
Nlets Lead Software Engineer

Office: (623) 308-3511 | Fax: (623) 308-3501
1918 W. Whispering Wind Drive | Phoenix, AZ 85085
ksilhol@nlets.org | www.nlets.org

Nlets - the International Justice and Public Safety Network

From: Bonnie Locke
Sent: Friday, November 21, 2014 2:05 PM
To: Kate Silhol
Cc: Rep - CA - Basco, Julie
Subject: DL Photo Sharing in CA
Importance: High

Hi Kate,

I have some potentially good news. Julie is going to talk with her contract programmers to see what it would take to potentially do the programming to be able to RECEIVE DL images from out of state.

She asked about image size and any specifications she should share with her staff. Could you possibly provide anything she might need? I started to point her to the WIKI but wanted to be sure she has the right information.

Thanks!
Bonnie

Bonnie Locke

Nlets Director of Business Development

Office: (623) 308-3504 | Fax: (623) 308-3501

1918 W. Whispering Wind Dr. | Phoenix, AZ 85085

blocke@nlets.org | www.nlets.org

Nlets - the International Justice and Public Safety Network

CONFIDENTIALITY NOTICE: This communication with its contents may contain confidential and/or legally privileged information. It is solely for the use of the intended recipient(s). Unauthorized interception, review, use or disclosure is prohibited and may violate applicable laws including the Electronic Communications Privacy Act. If you are not the intended recipient, please contact the sender and destroy all copies of the communication.

CONFIDENTIALITY NOTICE: This communication with its contents may contain confidential and/or legally privileged information. It is solely for the use of the intended recipient(s). Unauthorized interception, review, use or disclosure is prohibited and may violate applicable laws including the Electronic Communications Privacy Act. If you are not the intended recipient, please contact the sender and destroy all copies of the communication.

Julie Basco

From: Bonnie Locke <blocke@nlets.org>
Sent: Monday, December 08, 2014 2:16 PM
To: Julie Basco
Subject: RE: BAF to receive DL Photos - deadline to submit Dec 12

The BAF sometimes asks people applying the following questions so if you are able to answer any ahead of time that helps:

Is the funding you are requesting considered support and maintenance?

2. How will you fund this effort when BAF funds are exhausted?
3. Please explain how this request will benefit other States and the Nlets community as a whole?
4. What capabilities will be lost if you do not receive this BAF funding for this effort?
5. How will these lost capabilities impact your state and the states around you?
6. How are you accomplishing this currently?
7. If your BAF Application is unsuccessful, what will the timeline be for you to accomplish with state funds?

Here is some sample text:

The Colorado Bureau of Investigation (CBI) is initiating a project with the Colorado Department of Revenue (DOR) to join the Nlets Interstate Sharing of Photos (NISP) project by obtaining driver's license and identification card photographs stored by DOR, and making them available upon driver's license query (DO) by operator license number (OLN), known to DOR as Personal Identification Number (PIN). Due to Colorado's position along Interstates 25 and 70, criminal elements may pass freely between Colorado and its surrounding neighbors. As Colorado is one of the few states in the western United States who has yet to provide driver's license photos to law enforcement, Colorado residents identification is more desirable for fraudulent use due to the inability to quickly verify the person presenting a driver's license is the same person to whom DOR issued the license. Colorado has 3.8 million licensed drivers, as well as many residents with Colorado identification cards issued. By adding the driver's license and identification cards for the 5.1 million Colorado residents to the number of driver's license

photos available to law enforcement will be a significant helper in identifying those contacted during the course of law enforcement officers performing their assigned duties. Due to recent changes to Colorado law surrounding the legal use of marijuana both recreationally and for medicinal purposes, it is possible that Colorado driver's license and identification cards will become more attractive targets for identity thieves and those outside the state of Colorado with interest in obtaining a medical marijuana permit or marijuana for recreational use. Colorado medical marijuana cards do not show the picture of the cardholder, so using a driver's license photo to confirm identity may also prevent fraudulent use of stolen medical marijuana cards and prevent sharing of medical marijuana cards. There have been reports that states surrounding Colorado have started viewing Colorado vehicles with additional scrutiny due to the changes in marijuana laws. For this reason, there is a clear benefit to the law abiding citizen to adding an additional degree of law enforcement's confidence to their stated identity. The DOR Chief Fraud Investigator has voiced support for this project because it allows officers nationwide to more readily detect a fraudulent Colorado driver's license or identification card. By identifying a compromised identification card faster, officers nationwide will improve the chances of apprehending those who violate Colorado law by counterfeiting Colorado identification documents and can help more rapidly uncover identity thieves.

Currently, driver's license and identification card photos are available to law enforcement upon request from DOR. Requested photos are sent to the requesting officer using email. Due to the privacy concerns surrounding Driver's license data and images, email is not the best means of sending the images and data. Email systems store information in cloud environments, usually outside the control of both sender and recipient. Additionally, email systems typically do not use encryption making the information susceptible to interception and misuse by a third party. By moving the transmission of driver's license and identification card photos, the CBI and Nlets will also improve the security and audit trail of driver's license and identification card photos retrieved by law enforcement, thereby improving accountability for misuse.

The Arizona Department of Public Safety (DPS) is requesting financial and project management assistance from Nlets and San Diego's Automated Regional Justice Information System (ARJIS) to upgrade the automation systems at DPS and at the Arizona Department of Transportation (ADOT) to allow us to share Arizona driver's license photo sharing through the Nlets NJIN system to all of the Nlets user community. DL photo sharing provides a critical capability to law enforcement. ARJIS has agreed to fund \$70,000 of the Arizona DL photo sharing project out of their Office of Justice Programs Grant funding. An agreement is or will be in place between Nlets and ARJIS and ARJIS will pay Nlets directly for the work completed on the project. This will be a cooperative effort within the state of Arizona between the

Arizona Department of Public Safety, the Department of Administration, and the Department of Transportation. The Department of Administration is the central repository for the IBM mainframe software that will be used for this project and will be the owner of the IBM software. The Department of Transportation will implement a software solution that will allow queries of DL photos in real time. DPS is already connected to the Department of Transportation and at project completion will be pulling the driver's license photos from their SQL database in real time, allowing access to law enforcement agencies across the nation. Although Arizona users currently have a method of retrieving driver's license images, this solution will return the image with the rest of the driver's license information eliminating the need to make a separate transaction on another system. DPS will not require additional vendor support to implement these efforts and we will be absorbing the cost of our IT staff time to throughout this project. The mirror image of the Department of Motor Vehicle data along with the driver's license photos will be available to law enforcement 24/7/365. The Department of Administration will require a significant amount of vendor/software support from IBM. A cost sheet is attached to this request. They are requesting financial assistance for the vendor support but will provide internal IT support at no cost. The ADOT will also require vendor/software support from IBM and is asking for assistance from Nlets but has agreed to an additional \$38,808 in funding towards the project. The Department of Transportation has also committed to absorb any and all ongoing maintenance fees. ADOT will also provide their staff support time necessary to ensure that the resource is available. The state of Arizona realizes that DL photos are an invaluable tool for law enforcement and significantly aids in the day to day safety of our officers and those of neighboring states. Ready availability to driver's license photos is critical to both investigators and patrol officers. They enhance officer and public safety and help to identify suspects more quickly. Their availability during a traffic stop is often critical. The Arizona Department of Public Safety would like to officially request assistance from the Brodie Assistance Fund

Bonnie Locke

Nlets Director of Business Development

Office: (623) 308-3504 | Fax: (623) 308-3501
1918 W. Whispering Wind Dr. | Phoenix, AZ 85085
blocke@nlets.org | www.nlets.org

Nlets - the International Justice and Public Safety Network

From: Julie Basco [mailto:Julie.Basco@doj.ca.gov]
Sent: Monday, December 8, 2014 3:55 PM
To: Bonnie Locke
Subject: RE: BAF to receive DL Photos - deadline to submit Dec 12

OK, will try to get that by tomorrow.

From: Bonnie Locke [mailto:blocke@nlets.org]
Sent: Monday, December 08, 2014 1:55 PM
To: Julie Basco
Subject: RE: BAF to receive DL Photos - deadline to submit Dec 12
Importance: High

Hi Julie – I am on a call just finishing up and will call but I will need an SOW from your vendor to attach to this.

Bonnie Locke

Nlets Director of Business Development

Office: (623) 308-3504 | Fax: (623) 308-3501
1918 W. Whispering Wind Dr. | Phoenix, AZ 85085
blocke@nlets.org | www.nlets.org

Nlets - the International Justice and Public Safety Network

From: Julie Basco [mailto:Julie.Basco@doj.ca.gov]
Sent: Monday, December 8, 2014 3:48 PM
To: Bonnie Locke
Subject: RE: BAF to receive DL Photos - deadline to submit Dec 12

From: Bonnie Locke [mailto:blocke@nlets.org]
Sent: Monday, December 08, 2014 9:54 AM

To: Julie Basco

Subject: RE: BAF to receive DL Photos - deadline to submit Dec 12

Hi Julie – I am on my way to Phoenix for the rest of the week – call my cell if you need anything – 602-402-0056

Bonnie Locke

Nlets Director of Business Development

Office: (623) 308-3504 | Fax: (623) 308-3501

1918 W. Whispering Wind Dr. | Phoenix, AZ 85085

blocke@nlets.org | www.nlets.org

Nlets - the International Justice and Public Safety Network

From: Bonnie Locke

Sent: Thursday, December 4, 2014 2:33 PM

To: Rep - CA - Basco, Julie (julie.basco@doj.ca.gov)

Subject: FW: BAF to receive DL Photos - deadline to submit Dec 12

YAY!!

Bonnie Locke

Nlets Director of Business Development

Office: (623) 308-3504 | Fax: (623) 308-3501

1918 W. Whispering Wind Dr. | Phoenix, AZ 85085

blocke@nlets.org | www.nlets.org

Nlets - the International Justice and Public Safety Network

From: Kate Silhol

Sent: Thursday, December 4, 2014 10:03 AM

To: Bonnie Locke
Subject: RE: BAF to receive DL Photos - deadline to submit Dec 12

Just wanted to let you know that I spoke with the CA technical team today and they seem ready to go. They asked me about funding and I said that you will work with Julie on that – hopefully that was the correct answer!

From: Bonnie Locke
Sent: Wednesday, December 3, 2014 8:59 AM
To: Rep - CA - Basco, Julie
Cc: Kate Silhol
Subject: RE: BAF to receive DL Photos - deadline to submit Dec 12
Importance: High

Hi Julie.

Kate has not heard from anyone. If you want to provide contact information she can try to reach him as well?

Thanks,
Bonnie

Bonnie Locke
Nlets Director of Business Development

Office: (623) 308-3504 | Fax: (623) 308-3501
1918 W. Whispering Wind Dr. | Phoenix, AZ 85085
blocke@nlets.org | www.nlets.org

Nlets - the International Justice and Public Safety Network

From: Julie Basco [<mailto:Julie.Basco@doj.ca.gov>]
Sent: Tuesday, December 2, 2014 7:25 PM
To: Bonnie Locke
Subject: RE: BAF to receive DL Photos - deadline to submit Dec 12

Did someone (Kirk Beardwood) call Kate?

From: Bonnie Locke [<mailto:blocke@nlets.org>]
Sent: Tuesday, December 02, 2014 8:59 AM
To: Julie Basco

Subject: BAF to receive DL Photos - deadline to submit Dec 12
Importance: High

Hi Julie!

How did the conversation go with your programmers? Anything I can do to help?

From: Kate Silhol
Sent: Friday, November 21, 2014 3:11 PM
To: Bonnie Locke
Cc: Rep - CA - Basco, Julie
Subject: RE: DL Photo Sharing in CA

Sure thing. Hi Julie, essentially, when you send a request, you'll need to indicate that a photo is being requested via the IMQ/ tag or its XML equivalent. In order to receive images in the responses, you'll need to be set up for XML for DRs. The XML DR will contain an element with a Base64 encoded image. The images are generally around 25k and that's what we ask states to aim for although I have occasionally seen larger (40k) images. The wiki is the best spot for some initial documents and I can provide you the schemas if you know which version of XML you'll be implementing (GJXDM or NIEM). Please let me know if you have any other questions. Thanks,

Kate Silhol
Nlets Lead Software Engineer

Office: (623) 308-3511 | Fax: (623) 308-3501
1918 W. Whispering Wind Drive | Phoenix, AZ 85085
ksilhol@nlets.org | www.nlets.org

Nlets - the International Justice and Public Safety Network

From: Bonnie Locke
Sent: Friday, November 21, 2014 2:05 PM
To: Kate Silhol
Cc: Rep - CA - Basco, Julie
Subject: DL Photo Sharing in CA
Importance: High

Hi Kate,

I have some potentially good news. Julie is going to talk with her contract programmers to see what it would take to potentially do the programming to be able to RECEIVE DL images from out of state.

She asked about image size and any specifications she should share with her staff. Could you possibly provide anything she might need? I started to point her to the WIKI but wanted to be sure she has the right information.

Thanks!
Bonnie

Bonnie Locke
Nlets Director of Business Development

Office: (623) 308-3504 | Fax: (623) 308-3501
1918 W. Whispering Wind Dr. | Phoenix, AZ 85085
blocke@nlets.org | www.nlets.org

Nlets - the International Justice and Public Safety Network

CONFIDENTIALITY NOTICE: This communication with its contents may contain confidential and/or legally privileged information. It is solely for the use of the intended recipient(s). Unauthorized interception, review, use or disclosure is prohibited and may violate applicable laws including the Electronic Communications Privacy Act. If you are not the intended recipient, please contact the sender and destroy all copies of the communication.

CONFIDENTIALITY NOTICE: This communication with its contents may contain confidential and/or legally privileged information. It is solely for the use of the intended recipient(s). Unauthorized interception, review, use or disclosure is prohibited and may violate applicable laws including the Electronic Communications Privacy Act. If you are not the intended recipient, please contact the sender and destroy all copies of the communication.

CONFIDENTIALITY NOTICE: This communication with its contents may contain confidential and/or legally privileged information. It is solely for the use of the intended recipient(s). Unauthorized interception, review, use or disclosure is prohibited and may violate applicable laws including the Electronic Communications Privacy Act. If you are not the intended recipient, please contact the sender and destroy all copies of the communication.

Julie Basco

From: Bonnie Locke <blocke@nlets.org>
Sent: Monday, December 08, 2014 2:19 PM
To: Julie Basco
Subject: a few more

The West Virginia State Police (WVSP) would like expand the functionality of the State's law enforcement telecommunications network (WEAPON) through the sharing of Driver's License photos currently being managed and housed by the West Virginia Division of Motor Vehicles (DMV). Funding for the WVSP to participate is anticipated to be \$66,412.00. The WVSP respectfully requests the necessary funding to enable our participation through the acquisition of software development and system modifications which are necessary to accomplish the project.

The WVSP is the State of West Virginia's CJIS Systems Agency (CSA) for access to the Federal Bureau of Investigation's Criminal Justice Information Systems (CJIS) Wide Area Network (WAN), as well as, the control point for Nlets. As the CSA the WVSP is in the perfect position to engage all participants in the Driver's License Photo Sharing Project. Additionally, the WVSP has obtained agreements by all parties which would be required to gather, collect and share driver's license photos with law enforcement and criminal justice personnel throughout the state of West Virginia and the nation.

As such, West Virginia intends to participate in the Driver's License Photo Sharing Project. We believe that the sharing of a photo in connection with a state record, inclusive of criminal RAP sheets, driver's information and other reports currently available, is paramount in providing a law enforcement officer and criminal justice personnel the necessary and accurate information to be able to verify that the person they have in front of them is the correct one for which they have requested the criminal report or other information. We believe that providing this photo nationwide to all law enforcement officers or agencies is a step in the right direction to increase officer safety, as well as prudent implementation of the information received. The photographic information will aid law enforcement and

criminal justice personnel in swift decision making and lead to enhanced law enforcement and criminal justice actions.

The WVSP understands that biometrics (fingerprints, etc.) are the recognized standard for positive identification of an individual and linking that individual with past records. Regretfully, the tools required for rapid ID which utilize fingerprints is not pervasive throughout the state or nation in the law enforcement community. However, computers and other tools which are able to display the photograph in connection with a record are currently available to most, if not all, within this community.

With the funding requested we will be able to provide driver's license photos to law enforcement and criminal justice personnel both in state and nationally within a telecommunications system which is both secure and easily accessible by the law enforcement officers and criminal justice personnel and their agencies.

The West Virginia Division of Motor Vehicles (DMV) has recently upgraded the driver's system with a new system and vendor. Marquis, the DMV vendor, has agreed to provide the interface for law enforcement officers and criminal justice personnel and their agencies access to the driver's photos within DMV via a secure tunnel to the WVSP. Computer Projects of Illinois (CPI), the telecommunications vendor for the WVSP, manages the WVSP telecommunications switch and all interfaces which connect to the switch, both internally and externally.

CPI and Marquis have agreed on the process and requirements for interface to function as the WVSP anticipated. CPI has provided the required quote to complete the implementation of this project. The cost for the Marquis portion of this project is going to be covered by DMV. Attached is the quote and SOW for CPI.

The NLETS Interstate Sharing of Photos (NISP) Project is an ongoing effort to enable law enforcement users nationwide to exchange driver's license photo across state divisions via the NLETS communication network. This function, currently only available to state motor vehicle departments, will provide a welcome addition to the tools available to law enforcement personnel. The technical specifications detailing the NISP Project are documented in the NLETS Interstate Sharing of Photos Technical Specifications; version 1.3 dated February 14, 2007.

The Missouri State Highway Patrol (MSHP) operates the MULES/4 (Missouri Uniform Law Enforcement System) and desires to participate in the sharing of driver images via NLETS, known as the "NISP Project." This

effort entails providing the capability on the live production hardware, utilizing the production driver's database, and communicating with the production NLETS system.

The purpose of this request is to implement a Statement of Work to be performed to achieve this objective. These changes will be implemented in the referenced phased approach and will coincide with changes to the NLETS system to support the NISP functionality.

Technical Architecture:

The current technical architecture is composed of elements both within MULES and at the Missouri DOR (Department of Revenue) system. The MULES Message Switch, running OpenFox™ by Computer Projects of Illinois (CPI), currently communicates with the Missouri DOR system utilizing two different interface methodologies:

- 1) An 'MQ' interface for all NLETS queries, including driver queries, for biographical information.
- 2) A legacy MULES interface to the MULES/3 system for image requests.

The MULES Message Switch currently communicates with the NLETS system using the legacy NLETS text message formats. The communications protocol is the NLETS sockets protocol over TCP/IP.

The proposed future technical architecture does not anticipate hardware changes in order to implement the project. The existing hardware platform will remain unchanged and no additional software products will be required. Software changes will be made to accommodate the functionality for the NISP project. The communications interface between NLETS and MULES/4 will be changed to support the CANDLE XML data format for driver query and driver responses. The communications protocol will remain unchanged as well.

Business Process:

The current MULES system supports the NLET standard driver's license query and response formats via the legacy DQ (Driver Query) and DR (Driver Response) transactions. These transactions are currently in NLETS 'native' or text mode. These transactions are fully documented in the NLETS User and Technical Guide. The MULES system processes in-state and out-of-state driver query (DQ) transactions. Both processes are described as follows:

Current out-of-state driver query request originating from MULES/4:

1. A user enters a DQ transaction from a workstation for an out-of-state driver. Out-of-state is defined as being an NLETS state code which is not the host state.
2. The MULES Message Switch parses, validates, and transforms the message as needed.
3. The DQ transaction is routed to the NLETS system.
4. NLETS receives and validates the transaction and sends it to the target state identified in the destination field of the query.
5. The target state will process the request, query the state DOR system, and return a response using a DR transaction.
6. The DR transaction will be received and returned to the requesting state via the MULES Message Switch, which parses, validates, and transforms the message as needed.
7. The MULES Message switch sends the DR transaction back to the originating user's workstation, completing the process.

Responding to an out-of-state DQ request comprises of the following steps:

1. The NLETS system receives a DQ and sends the message to the target state, in this case, Missouri, to the MULES Message Switch.
2. The MULES Message Switch receives, parses, validates, and transforms the message as needed.
3. The DQ transaction is sent to the Department of Revenue (DOR) system.
4. The DOR system processes the query request, composes an appropriate DR response message, and returns the response to the MULES system.
5. The DR response message is sent to the MULES Message Switch, which parses, validates, and transforms the message as needed.
6. The DR message is sent back to the NLETS system.

Future Business Process:

Julie Basco

From: Bonnie Locke <blocke@nlets.org>
Sent: Wednesday, December 10, 2014 11:59 AM
To: Julie Basco
Subject: how are you coming on the SOW?

Bonnie Locke

Nlets Director of Business Development

Office: (623) 308-3504 | Fax: (623) 308-3501
1918 W. Whispering Wind Dr. | Phoenix, AZ 85085
blocke@nlets.org | www.nlets.org

Nlets - the International Justice and Public Safety Network

Julie Basco

From: Bonnie Locke <blocke@nlets.org>
Sent: Thursday, December 11, 2014 3:43 PM
To: Julie Basco
Subject: Re: how are you coming on the SOW?

Ok!

On Dec 11, 2014, at 2:49 PM, Julie Basco <Julie.Basco@doj.ca.gov> wrote:

Hi Bonnie-

Please let me know if there are any questions. I very much appreciate all your help with this.

Julie
916-227-3854 = office
916-296-1464 = cellular

From: Bonnie Locke [<mailto:blocke@nlets.org>]
Sent: Wednesday, December 10, 2014 11:59 AM
To: Julie Basco
Subject: how are you coming on the SOW?

Bonnie Locke
Nlets Director of Business Development

Office: (623) 308-3504 | Fax: (623) 308-3501
1918 W. Whispering Wind Dr. | Phoenix, AZ 85085
blocke@nlets.org | www.nlets.org

Nlets - the International Justice and Public Safety Network

CONFIDENTIALITY NOTICE: This communication with its contents may contain confidential and/or legally privileged information. It is solely for the use of the intended recipient(s). Unauthorized interception, review, use or disclosure is prohibited and may violate applicable

laws including the Electronic Communications Privacy Act. If you are not the intended recipient, please contact the sender and destroy all copies of the communication.

<NLETS-BAF-DEC2014.pdf>

Julie Basco

From: Bonnie Locke <blocke@nlets.org>
Sent: Monday, December 15, 2014 6:45 AM
To: Julie Basco
Subject: CONGRATULATIONS!

Importance: High

Julie - You DL (receiving only) BAF was approved!

You will be hearing from an Nlets PM within a couple of weeks.

Thank you,
Bonnie

Bonnie Locke

Nlets Director of Business Development

Office: (623) 308-3504 | Fax: (623) 308-3501
1918 W. Whispering Wind Dr. | Phoenix, AZ 85085
blocke@nlets.org | www.nlets.org

Nlets - the International Justice and Public Safety Network

Julie Basco

From: Julie Basco
Sent: Thursday, November 20, 2014 6:31 PM
To: 'Bonnie Locke'
Subject: RE: Touch Base - CA

Hi Bonnie-

Hope you are well.

Let's try to talk tomorrow.

Julie

From: Bonnie Locke [<mailto:blocke@nlets.org>]
Sent: Wednesday, November 19, 2014 11:38 AM
To: Julie Basco
Subject: Touch Base - CA
Importance: High

Hi Julie!

How are you??

As we near the end of the year, I have been making a push to spend remaining BAF funds. I was going through our website and running some of the maps to see what projects States have gone live with – in particular DL photos, Corrections photos and TIPS.

As you know, I have BAF funds to implement all of these. I am encouraging Reps to submit their requests before the deadline of Dec 12, 2014.

It has been a while since we have talked. Is there anything I can be doing to support you more?

Are you interested in some training? Teri is more than willing to come out there.

BTW, I met your new Homeland Security person – Caroline? She is delightful.

Anyway, let me know your thoughts or I can call you as well.....thanks!

Bonnie

Bonnie Locke

Niets Director of Business Development

Office: (623) 308-3504 | Fax: (623) 308-3501
1918 W. Whispering Wind Dr. | Phoenix, AZ 85085
blocke@nlets.org | www.nlets.org

Niets - the International Justice and Public Safety Network

Julie Basco

From: Julie Basco
Sent: Tuesday, December 02, 2014 5:25 PM
To: 'Bonnie Locke'
Subject: RE: BAF to receive DL Photos - deadline to submit Dec 12

Did someone (Kirk Beardwood) call Kate?

From: Bonnie Locke [<mailto:blocke@nlets.org>]
Sent: Tuesday, December 02, 2014 8:59 AM
To: Julie Basco
Subject: BAF to receive DL Photos - deadline to submit Dec 12
Importance: High

Hi Julie!

How did the conversation go with your programmers? Anything I can do to help?

From: Kate Silhol
Sent: Friday, November 21, 2014 3:11 PM
To: Bonnie Locke
Cc: Rep - CA - Basco, Julie
Subject: RE: DL Photo Sharing in CA

Sure thing. Hi Julie, essentially, when you send a request, you'll need to indicate that a photo is being requested via the IMQ/ tag or its XML equivalent. In order to receive images in the responses, you'll need to be set up for XML for DRs. The XML DR will contain an element with a Base64 encoded image. The images are generally around 25k and that's what we ask states to aim for although I have occasionally seen larger (40k) images. The wiki is the best spot for some initial documents and I can provide you the schemas if you know which version of XML you'll be implementing (GJXDM or NIEM). Please let me know if you have any other questions. Thanks,

Kate Silhol
Nlets Lead Software Engineer

Office: (623) 308-3511 | Fax: (623) 308-3501
1918 W. Whispering Wind Drive | Phoenix, AZ 85085
ksilhol@nlets.org | www.nlets.org

Nlets - the International Justice and Public Safety Network

From: Bonnie Locke
Sent: Friday, November 21, 2014 2:05 PM
To: Kate Silhol

Cc: Rep - CA - Basco, Julie
Subject: DL Photo Sharing in CA
Importance: High

Hi Kate,

I have some potentially good news. Julie is going to talk with her contract programmers to see what it would take to potentially do the programming to be able to RECEIVE DL images from out of state.

She asked about image size and any specifications she should share with her staff. Could you possibly provide anything she might need? I started to point her to the WIKI but wanted to be sure she has the right information.

Thanks!
Bonnie

Bonnie Locke
Nlets Director of Business Development

Office: (623) 308-3504 | Fax: (623) 308-3501
1918 W. Whispering Wind Dr. | Phoenix, AZ 85085
blocke@nlets.org | www.nlets.org

Nlets - the International Justice and Public Safety Network

Julie Basco

From: Julie Basco
Sent: Monday, December 08, 2014 1:31 PM
To: 'Bonnie Locke'
Subject: RE: BAF to receive DL Photos - deadline to submit Dec 12

Ok, please call me when you can.

916-227-3854 = office
916-296-1464 = cellular

From: Bonnie Locke [mailto:blocke@nlets.org]
Sent: Monday, December 08, 2014 9:54 AM
To: Julie Basco
Subject: RE: BAF to receive DL Photos - deadline to submit Dec 12

Hi Julie – I am on my way to Phoenix for the rest of the week – call my cell if you need anything – 602-402-0056

Bonnie Locke

Nlets Director of Business Development

Office: (623) 308-3504 | Fax: (623) 308-3501
1918 W. Whispering Wind Dr. | Phoenix, AZ 85085
blocke@nlets.org | www.nlets.org

Nlets - the International Justice and Public Safety Network

From: Bonnie Locke
Sent: Thursday, December 4, 2014 2:33 PM
To: Rep - CA - Basco, Julie (julie.basco@doj.ca.gov)
Subject: FW: BAF to receive DL Photos - deadline to submit Dec 12

YAY!!

Bonnie Locke

Niets Director of Business Development

Office: (623) 308-3504 | Fax: (623) 308-3501
1918 W. Whispering Wind Dr. | Phoenix, AZ 85085
blocke@nlets.org | www.nlets.org

Niets - the International Justice and Public Safety Network

From: Kate Silhol
Sent: Thursday, December 4, 2014 10:03 AM
To: Bonnie Locke
Subject: RE: BAF to receive DL Photos - deadline to submit Dec 12

Just wanted to let you know that I spoke with the CA technical team today and they seem ready to go. They asked me about funding and I said that you will work with Julie on that – hopefully that was the correct answer!

From: Bonnie Locke
Sent: Wednesday, December 3, 2014 8:59 AM
To: Rep - CA - Basco, Julie
Cc: Kate Silhol
Subject: RE: BAF to receive DL Photos - deadline to submit Dec 12
Importance: High

Hi Julie.

Kate has not heard from anyone. If you want to provide contact information she can try to reach him as well?

Thanks,
Bonnie

Bonnie Locke
Nlets Director of Business Development

Office: (623) 308-3504 | Fax: (623) 308-3501
1918 W. Whispering Wind Dr. | Phoenix, AZ 85085
blocke@nlets.org | www.nlets.org

Nlets - the International Justice and Public Safety Network

From: Julie Basco [<mailto:Julie.Basco@doj.ca.gov>]
Sent: Tuesday, December 2, 2014 7:25 PM
To: Bonnie Locke
Subject: RE: BAF to receive DL Photos - deadline to submit Dec 12

Did someone (Kirk Beardwood) call Kate?

From: Bonnie Locke [<mailto:blocke@nlets.org>]
Sent: Tuesday, December 02, 2014 8:59 AM
To: Julie Basco
Subject: BAF to receive DL Photos - deadline to submit Dec 12
Importance: High

Hi Julie!

How did the conversation go with your programmers? Anything I can do to help?

From: Kate Silhol
Sent: Friday, November 21, 2014 3:11 PM
To: Bonnie Locke
Cc: Rep - CA - Basco, Julie
Subject: RE: DL Photo Sharing in CA

Sure thing. Hi Julie, essentially, when you send a request, you'll need to indicate that a photo is being requested via the IMQ/ tag or its XML equivalent. In order to receive images in the responses, you'll need to be set up for XML for DRs. The XML DR will contain an element with a Base64 encoded image. The images are generally around 25k and that's what we ask states to aim for although I have occasionally seen larger (40k) images. The wiki is the best spot for some initial documents and I can provide you the schemas if you know which version of XML you'll be implementing (GJXDM or NIEM). Please let me know if you have any other questions. Thanks,

Kate Silhol
Nlets Lead Software Engineer

Office: (623) 308-3511 | Fax: (623) 308-3501
1918 W. Whispering Wind Drive | Phoenix, AZ 85085
ksilhol@nlets.org | www.nlets.org

Nlets - the International Justice and Public Safety Network

From: Bonnie Locke
Sent: Friday, November 21, 2014 2:05 PM
To: Kate Silhol
Cc: Rep - CA - Basco, Julie
Subject: DL Photo Sharing in CA
Importance: High

Hi Kate,

I have some potentially good news. Julie is going to talk with her contract programmers to see what it would take to potentially do the programming to be able to RECEIVE DL images from out of state.

She asked about image size and any specifications she should share with her staff. Could you possibly provide anything she might need? I started to point her to the WIKI but wanted to be sure she has the right information.

Thanks!
Bonnie

Bonnie Locke
Nlets Director of Business Development

Office: (623) 308-3504 | Fax: (623) 308-3501
1918 W. Whispering Wind Dr. | Phoenix, AZ 85085
blocke@nlets.org | www.nlets.org

Nlets - the International Justice and Public Safety Network

CONFIDENTIALITY NOTICE: This communication with its contents may contain confidential and/or legally privileged information. It is solely for the use of the intended recipient(s). Unauthorized interception, review, use or disclosure is prohibited and may violate applicable laws including the Electronic Communications Privacy Act. If you are not the intended recipient, please contact the sender and destroy all copies of the communication.

Julie Basco

From: Julie Basco
Sent: Monday, December 08, 2014 1:48 PM
To: 'Bonnie Locke'
Subject: RE: BAF to receive DL Photos - deadline to submit Dec 12
Attachments: CADOJ-BAF-DEC2014.pdf

From: Bonnie Locke [mailto:bloque@nlets.org]
Sent: Monday, December 08, 2014 9:54 AM
To: Julie Basco
Subject: RE: BAF to receive DL Photos - deadline to submit Dec 12

Hi Julie – I am on my way to Phoenix for the rest of the week – call my cell if you need anything – 602-402-0056

Bonnie Locke
Nlets Director of Business Development

Office: (623) 308-3504 | Fax: (623) 308-3501
1918 W. Whispering Wind Dr. | Phoenix, AZ 85085
bloque@nlets.org | www.nlets.org

Nlets - the International Justice and Public Safety Network

From: Bonnie Locke
Sent: Thursday, December 4, 2014 2:33 PM
To: Rep - CA - Basco, Julie (julie.basco@doj.ca.gov)
Subject: FW: BAF to receive DL Photos - deadline to submit Dec 12

YAY!!

Bonnie Locke
Nlets Director of Business Development

Office: (623) 308-3504 | Fax: (623) 308-3501
1918 W. Whispering Wind Dr. | Phoenix, AZ 85085
blocke@nlets.org | www.nlets.org

Nlets - the International Justice and Public Safety Network

From: Kate Silhol
Sent: Thursday, December 4, 2014 10:03 AM
To: Bonnie Locke
Subject: RE: BAF to receive DL Photos - deadline to submit Dec 12

Just wanted to let you know that I spoke with the CA technical team today and they seem ready to go. They asked me about funding and I said that you will work with Julie on that – hopefully that was the correct answer!

From: Bonnie Locke
Sent: Wednesday, December 3, 2014 8:59 AM
To: Rep - CA - Basco, Julie
Cc: Kate Silhol
Subject: RE: BAF to receive DL Photos - deadline to submit Dec 12
Importance: High

Hi Julie.

Kate has not heard from anyone. If you want to provide contact information she can try to reach him as well?

Thanks,
Bonnie

Bonnie Locke
Nlets Director of Business Development

Office: (623) 308-3504 | Fax: (623) 308-3501
1918 W. Whispering Wind Dr. | Phoenix, AZ 85085
blocke@nlets.org | www.nlets.org

Nlets - the International Justice and Public Safety Network

From: Julie Basco [mailto:Julie.Basco@doi.ca.gov]
Sent: Tuesday, December 2, 2014 7:25 PM
To: Bonnie Locke
Subject: RE: BAF to receive DL Photos - deadline to submit Dec 12

Did someone (Kirk Beardwood) call Kate?

From: Bonnie Locke [mailto:blocke@nlets.org]
Sent: Tuesday, December 02, 2014 8:59 AM
To: Julie Basco
Subject: BAF to receive DL Photos - deadline to submit Dec 12
Importance: High

Hi Julie!

How did the conversation go with your programmers? Anything I can do to help?

From: Kate Silhol
Sent: Friday, November 21, 2014 3:11 PM
To: Bonnie Locke
Cc: Rep - CA - Basco, Julie
Subject: RE: DL Photo Sharing in CA

Sure thing. Hi Julie, essentially, when you send a request, you'll need to indicate that a photo is being requested via the IMQ/ tag or its XML equivalent. In order to receive images in the responses, you'll need to be set up for XML for DRs. The XML DR will contain an element with a Base64 encoded image. The images are generally around 25k and that's what we ask states to aim for although I have occasionally seen larger (40k) images. The wiki is the best spot for some initial documents and I can provide you the schemas if you know which version of XML you'll be implementing (GJXDM or NIEM). Please let me know if you have any other questions. Thanks,

Kate Silhol
Nlets Lead Software Engineer

Office: (623) 308-3511 | Fax: (623) 308-3501
1918 W. Whispering Wind Drive | Phoenix, AZ 85085
ksilhol@nlets.org | www.nlets.org

Nlets - the International Justice and Public Safety Network

From: Bonnie Locke
Sent: Friday, November 21, 2014 2:05 PM
To: Kate Silhol

Cc: Rep - CA - Basco, Julie
Subject: DL Photo Sharing in CA
Importance: High

Hi Kate,

I have some potentially good news. Julie is going to talk with her contract programmers to see what it would take to potentially do the programming to be able to RECEIVE DL images from out of state.

She asked about image size and any specifications she should share with her staff. Could you possibly provide anything she might need? I started to point her to the WIKI but wanted to be sure she has the right information.

Thanks!
Bonnie

Bonnie Locke
Nlets Director of Business Development

Office: (623) 308-3504 | Fax: (623) 308-3501
1918 W. Whispering Wind Dr. | Phoenix, AZ 85085
blocke@nlets.org | www.nlets.org

Nlets - the International Justice and Public Safety Network

CONFIDENTIALITY NOTICE: This communication with its contents may contain confidential and/or legally privileged information. It is solely for the use of the intended recipient(s). Unauthorized interception, review, use or disclosure is prohibited and may violate applicable laws including the Electronic Communications Privacy Act. If you are not the intended recipient, please contact the sender and destroy all copies of the communication.

Nlets Brodie Assistance Fund Application

Print Form

All fields must be must be completed or application will be denied - email completed form to blocke@nlets.org

Applicant Information

Name: Julie Basco	Are you the Appointed Nlets Rep?: <input type="checkbox"/> Yes	Date: 2/5/15
Email: julie.basco@doj.ca.gov	Organization: California Department of Justice	Phone #: 916-227-3854

Purpose Of Request

Type: Special Project	Date(s): December 2014 to April 2015	Location: Sacramento, CA
Event/Project Name & Description: Inter-State Driver's License Photograph Return for California		

Expenses

Event/Project Cost: 50,000	Airfare: <input type="text"/>		
Ground Transportation: <input type="text"/>	# of Days: <input type="text"/>	Transportation Total: <input type="text"/>	Total expenses: 50,000
Parking: <input type="text"/>	# of Days: <input type="text"/>	Parking Total: <input type="text"/>	# Of Attendees Applied for: <input type="text"/>
Lodging Per Night: <input type="text"/>	# of Nights: <input type="text"/>	Lodging Total: <input type="text"/>	Total Amount Requested: \$ 000.00
Daily Per Diem: <input type="text"/>	# of Days: <input type="text"/>	Per Diem Total: <input type="text"/>	

Name(s) of attendee(s)

THIS CERTIFICATION MANDATORY - Forms submitted without this box checked will be denied: By checking this box, I certify all financial avenues within the State have been exhausted; without BAF approval, there is no other way to fund this project/training.

Justification for request (minimum 500 words) Indicate problem statement and proposed solution. Use additional supporting documentation if necessary.

The California Department of Justice (DOJ) requests \$50,000 to participate in the inter-state driver's license photograph sharing initiative. \$40,000 for Computer Deductions Incorporated to develop an XML solution. \$10,000 for additional storage at the California DOJ.

California DOJ technical staff arrived at these costs after discussion with Kate Silhol.

Return completed form to:

blocke@nlets.org

Nlets Staff Use Only - Status & Comments

Received Date: <input style="width: 100%;" type="text"/>	Comments, Notes, Name of Person Taking Action:	
Approved?: <input type="radio"/> YES <input type="radio"/> NO		

Julie Basco

From: Julie Basco
Sent: Monday, December 08, 2014 1:55 PM
To: 'Bonnie Locke'
Subject: RE: BAF to receive DL Photos - deadline to submit Dec 12

OK, will try to get that by tomorrow.

From: Bonnie Locke [mailto:bloque@nlets.org]
Sent: Monday, December 08, 2014 1:55 PM
To: Julie Basco
Subject: RE: BAF to receive DL Photos - deadline to submit Dec 12
Importance: High

Hi Julie – I am on a call just finishing up and will call but I will need an SOW from your vendor to attach to this.

Bonnie Locke

Nlets Director of Business Development

Office: (623) 308-3504 | Fax: (623) 308-3501
1918 W. Whispering Wind Dr. | Phoenix, AZ 85085
bloque@nlets.org | www.nlets.org

Nlets - the International Justice and Public Safety Network

From: Julie Basco [mailto:Julie.Basco@doj.ca.gov]
Sent: Monday, December 8, 2014 3:48 PM
To: Bonnie Locke
Subject: RE: BAF to receive DL Photos - deadline to submit Dec 12

From: Bonnie Locke [mailto:bloque@nlets.org]
Sent: Monday, December 08, 2014 9:54 AM
To: Julie Basco
Subject: RE: BAF to receive DL Photos - deadline to submit Dec 12

Hi Julie – I am on my way to Phoenix for the rest of the week – call my cell if you need anything
– 602-402-0056

Bonnie Locke

Nlets Director of Business Development

Office: (623) 308-3504 | Fax: (623) 308-3501
1918 W. Whispering Wind Dr. | Phoenix, AZ 85085
blocke@nlets.org | www.nlets.org

Nlets - the International Justice and Public Safety Network

From: Bonnie Locke
Sent: Thursday, December 4, 2014 2:33 PM
To: Rep - CA - Basco, Julie (julie.basco@doj.ca.gov)
Subject: FW: BAF to receive DL Photos - deadline to submit Dec 12

YAY!!

Bonnie Locke

Nlets Director of Business Development

Office: (623) 308-3504 | Fax: (623) 308-3501
1918 W. Whispering Wind Dr. | Phoenix, AZ 85085
blocke@nlets.org | www.nlets.org

Nlets - the International Justice and Public Safety Network

From: Kate Silhol
Sent: Thursday, December 4, 2014 10:03 AM
To: Bonnie Locke
Subject: RE: BAF to receive DL Photos - deadline to submit Dec 12

Just wanted to let you know that I spoke with the CA technical team today and they seem ready to go. They asked me about funding and I said that you will work with Julie on that – hopefully that was the correct answer!

From: Bonnie Locke
Sent: Wednesday, December 3, 2014 8:59 AM
To: Rep - CA - Basco, Julie
Cc: Kate Silhol
Subject: RE: BAF to receive DL Photos - deadline to submit Dec 12
Importance: High

Hi Julie.

Kate has not heard from anyone. If you want to provide contact information she can try to reach him as well?

Thanks,
Bonnie

Bonnie Locke
Nlets Director of Business Development

Office: (623) 308-3504 | Fax: (623) 308-3501
1918 W. Whispering Wind Dr. | Phoenix, AZ 85085
blocke@nlets.org | www.nlets.org

Nlets - the International Justice and Public Safety Network

From: Julie Basco [<mailto:Julie.Basco@doj.ca.gov>]
Sent: Tuesday, December 2, 2014 7:25 PM
To: Bonnie Locke
Subject: RE: BAF to receive DL Photos - deadline to submit Dec 12

Did someone (Kirk Beardwood) call Kate?

From: Bonnie Locke [<mailto:blocke@nlets.org>]
Sent: Tuesday, December 02, 2014 8:59 AM
To: Julie Basco
Subject: BAF to receive DL Photos - deadline to submit Dec 12
Importance: High

Hi Julie!

How did the conversation go with your programmers? Anything I can do to help?

From: Kate Silhol
Sent: Friday, November 21, 2014 3:11 PM
To: Bonnie Locke
Cc: Rep - CA - Basco, Julie
Subject: RE: DL Photo Sharing in CA

Sure thing. Hi Julie, essentially, when you send a request, you'll need to indicate that a photo is being requested via the IMQ/ tag or its XML equivalent. In order to receive images in the responses, you'll need to be set up for XML for DRs. The XML DR will contain an element with a Base64 encoded image. The images are generally around 25k and that's what we ask states to aim for although I have occasionally seen larger (40k) images. The wiki is the best spot for some initial documents and I can provide you the schemas if you know which version of XML you'll be implementing (GJXDM or NIEM). Please let me know if you have any other questions. Thanks,

Kate Silhol
Nlets Lead Software Engineer

Office: (623) 308-3511 | Fax: (623) 308-3501
1918 W. Whispering Wind Drive | Phoenix, AZ 85085
ksilhol@nlets.org | www.nlets.org

Nlets - the International Justice and Public Safety Network

From: Bonnie Locke
Sent: Friday, November 21, 2014 2:05 PM
To: Kate Silhol
Cc: Rep - CA - Basco, Julie
Subject: DL Photo Sharing in CA
Importance: High

Hi Kate,

I have some potentially good news. Julie is going to talk with her contract programmers to see what it would take to potentially do the programming to be able to RECEIVE DL images from out of state.

She asked about image size and any specifications she should share with her staff. Could you possibly provide anything she might need? I started to point her to the WIKI but wanted to be sure she has the right information.

Thanks!
Bonnie

Bonnie Locke
Nlets Director of Business Development

Office: (623) 308-3504 | Fax: (623) 308-3501
1918 W. Whispering Wind Dr. | Phoenix, AZ 85085
blocke@nlets.org | www.nlets.org

Nlets - the International Justice and Public Safety Network

CONFIDENTIALITY NOTICE: This communication with its contents may contain confidential and/or legally privileged information. It is solely for the use of the intended recipient(s). Unauthorized interception, review, use or disclosure is prohibited and may violate applicable laws including the Electronic Communications Privacy Act. If you are not the intended recipient, please contact the sender and destroy all copies of the communication.

CONFIDENTIALITY NOTICE: This communication with its contents may contain confidential and/or legally privileged information. It is solely for the use of the intended recipient(s). Unauthorized interception, review, use or disclosure is prohibited and may violate applicable laws including the Electronic Communications Privacy Act. If you are not the intended recipient, please contact the sender and destroy all copies of the communication.

Julie Basco

From: Julie Basco
Sent: Thursday, December 11, 2014 9:01 AM
To: 'Bonnie Locke'
Subject: RE: how are you coming on the SOW?

Should have everything done today.

From: Bonnie Locke [<mailto:blocke@nlets.org>]
Sent: Wednesday, December 10, 2014 11:59 AM
To: Julie Basco
Subject: how are you coming on the SOW?

Bonnie Locke
Nlets Director of Business Development

Office: (623) 308-3504 | Fax: (623) 308-3501
1918 W. Whispering Wind Dr. | Phoenix, AZ 85085
blocke@nlets.org | www.nlets.org

Nlets - the International Justice and Public Safety Network

Julie Basco

From: Julie Basco
Sent: Thursday, December 11, 2014 1:48 PM
To: 'Bonnie Locke'
Subject: RE: how are you coming on the SOW?
Attachments: NLETS-BAF-DEC2014.pdf

Hi Bonnie-

Please let me know if there are any questions. I very much appreciate all your help with this.

Julie
916-227-3854 = office
916-296-1464 = cellular

From: Bonnie Locke [<mailto:blocke@nlets.org>]
Sent: Wednesday, December 10, 2014 11:59 AM
To: Julie Basco
Subject: how are you coming on the SOW?

Bonnie Locke

Nlets Director of Business Development

Office: (623) 308-3504 | Fax: (623) 308-3501
1918 W. Whispering Wind Dr. | Phoenix, AZ 85085
blocke@nlets.org | www.nlets.org

Nlets - the International Justice and Public Safety Network

Nlets Brodie Assistance Fund Application

Print Form

All fields must be must be completed or application will be denied - email completed form to blocke@nlets.org

Applicant Information

Name: JULIE BASCO Are you the Appointed Nlets Rep?: YES Date: 12/11/14
Email: julie.basco@doj.ca.gov Organization: CA DOJ Phone # 916-227-3854

Purpose Of Request

Type: SPECIAL PROJECT Date(s): DEC 2014 - APRIL 2015 Location: SACRAMENTO, CA
Event/Project Name & Description: INTER STATE DL PHOTOGRAPH SHARING RETURN

Event/Project Cost: \$50,000 Airfare:
Ground Transportation: # of Days: Transportation Total: Total expenses: \$50,000
Parking: # of Days: Parking Total: # Of Attendees Applied for:
Lodging Per Night: # of Nights: Lodging Total: Total Amount Requested: \$50,000
Daily Per Diem: # of Days: Per Diem Total:

Name(s) of attendee(s)

THIS CERTIFICATION MANDATORY - Forms submitted without this box checked will be denied: By checking this box, I certify all financial avenues within the State have been exhausted; without BAF approval, there is no other way to fund this project/training.

Justification for request (minimum 500 words) Indicate problem statement and proposed solution. Use additional supporting documentation if necessary.

See attachments.

**Return completed form to:
blocke@nlets.org**

Nlets Staff Use Only - Status & Comments

Received Date: Comments, Notes, Name of Person Taking Action:
Approved?: YES NO

CALIFORNIA DEPARTMENT OF JUSTICE

NLETS - BRODY ASSISTANCE FUND

DECEMBER 2014

TO SAY THAT TODAY'S SOCIETY IS MOBILE IS A GROSS UNDERSTATEMENT. MILLIONS OF PEOPLE EFFORTLESSLY TRANSIT FROM ONE STATE TO ANOTHER EACH HOUR OF EVERY DAY. AS SUCH, THE DEPARTMENT OF JUSTICE'S (DOJ) PARTICIPATION IN NLETS INTER-STATE PHOTOGRAPH SHARING INITIATIVE, FOR DRIVER'S LICENSE PHOTOGRAPHS, WOULD PROVIDE CALIFORNIA LAW ENFORCEMENT AGENCIES A VALUABLE IDENTIFICATION TOOL.

THE DOJ HAS BEEN CONTEMPLATING PARTICIPATION IN THIS INITIATIVE FOR YEARS. THE BARRIER HAS BEEN SUSTAINING ENGAGEMENT FROM THE DEPARTMENT OF MOTOR VEHICLES (DMV) ON THE TOPIC OF ELECTRONIC SHARING OF CALIFORNIA DRIVER'S LICENSE PHOTOGRAPHS OUT OF STATE. BUT RECENTLY, PROGRESS HAS BEEN MADE THROUGH THE DOJ'S CALIFORNIA LAW ENFORCEMENT TELECOMMUNICATIONS SYSTEM (CLETS) ADVISORY COMMITTEE'S STANDING STRATEGIC PLANNING SUBCOMMITTEE (SSPS). THE SSPS RECOMMENDS STRATEGIC GOALS FOR THE CLETS AND HAS ADVANCED THIS TOPIC TO PRIORITY STATUS. THROUGH SSPS COORDINATION, THE THREE MAJOR CALIFORNIA LAW ENFORCEMENT ASSOCIATIONS AND THE DOJ WILL MEET WITH THE DMV DIRECTOR BEFORE MARCH 2015 TO DISCUSS THE DMV'S POLICY CONCERNS, INTEREST LEVEL AND MAP A PROGRESSIVE APPROACH TO PARTICIPATION. IN CALIFORNIA, THE DOJ IS PART OF THE OFFICE OF THE ATTORNEY GENERAL, A CONSTITUTIONAL OFFICE. THE DMV IS PART OF THE EXECUTIVE BRANCH OF GOVERNMENT REPORTING TO ANOTHER CONSTITUTIONAL OFFICER, THE GOVERNOR.

THE SSPS HAS DETERMINED THAT MOVING FORWARD TO ESTABLISH THE NECESSARY INFRASTRUCTURE TO ELECTRONICALLY RECEIVE DRIVER'S LICENSE PHOTOGRAPHS FROM OUT OF STATE WOULD BE HIGHLY BENEFICIAL AND ALSO, PROVIDE INCENTIVE TO THE DMV TO TAKE ACTION ON THIS TOPIC.

A STATEMENT OF WORK IS ATTACHED THAT DETAILS THE REQUEST FOR \$40,000 OF CONSULTING SERVICES AND \$10,000 FOR ADDITIONAL STORAGE AT THE DOJ.

IT IS KNOWN THAT BRODY ASSISTANCE FUND COMMITTEE HAS INTEREST IN THESE QUESTIONS; THEREFORE, A RESPONSE FOR EACH FOLLOWS:

IS THE FUNDING YOU ARE REQUESTING CONSIDERED SUPPORT AND MAINTENANCE?

NO. THE FUNDING WILL COVER ENHANCEMENTS TO BOTH THE CLETS AND THE SMARTJUSTICE APPLICATION. SMARTJUSTICE IS THE ATTORNEY'S GENERAL

Statement of Work

1 Background

The California Law Enforcement Telecommunications System (CLETS) is the state's message switch for the exchange of Law Enforcement data among California (local, county and state level) users and systems (e.g. ACHS and DMV); and external national and international users and systems via NCIC and NLETS.

- An XML based interface header structure designed to exchange legacy and XML message payloads is currently used between CLETS and California's New CJIS Control (NCC).
- CDI supported the successful implementation of a NIEM XML interface for the exchange of Criminal Rapsheets between California and other states via NLETS (CHIEF Project).
- CDI is currently supporting California's SmartJustice project which will be extended under this agreement to encompass the retrieval of other state driver photos via NLETS.

California DOJ is positioned to support a transition to XML based message formatting. The DL Photo Retrieval Project is a logical step in XML's implementation.

2 Proposal

California desires to participate in the NLETS DL Photo Retrieval using the National Information Exchange Model (NIEM) format for exchanging computerized Driver License data between NLETS and the CA DOJ. For CA DOJ, CLETS is a key architectural component to this effort.

This proposal is to provide the CLETS level XML specifications and testing support required of California to achieve a NLETS Photo Retrieval thru the SmartJustice Application Portal without disrupting the current processing of MSC transactions.

MARQUIS DATA SHARING PLATFORM THAT DISPLAYS DOJ DATA SYSTEMS AND COUNTY LEVEL LAW ENFORCEMENT AND PROBATION DATA SYSTEMS IN A SINGLE VIEW, WITH A SINGLE SIGN-ON BOTH TERMINAL AND MOBILE DEVICES. ONCE THE ENHANCEMENTS ARE ACCOMPLISHED, THE MAINTENANCE AGREEMENTS FOR BOTH CLETS AND SMARTJUSTICE WILL ENGAGE.

HOW WILL YOU FUND THIS EFFORT WHEN BAF FUNDS ARE EXHAUSTED?

VIA THE CLETS AND SMARTJUSTICE MAINTENANCE AGREEMENTS. ALSO, IF FUTURE ENHANCEMENTS ARE NEEDED THE SMARTJUSTICE APPLICATION IS CONTINUALLY EVOLVING AND THE OPPORTUNITY WOULD EXIST TO BRING THIS EFFORT INTO THAT FUNDING ARENA.

PLEASE EXPLAIN HOW THIS REQUEST WILL BENEFIT OTHER STATES AND THE NLETS COMMUNITY AS A WHOLE?

IDENTIFICATION. CALIFORNIA LAW ENFORCEMENT WILL BE MORE READILY ABLE TO ENGAGE WITH OUT OF STATE AGENCIES REGARDING THEIR CITIZENS.

WHAT CAPABILITIES WILL BE LOST IF YOU DO NOT RECEIVE THIS BRODY ASSISTANCE FUND FUNDING FOR THIS EFFORT?

IDENTIFICATION OF OUT OF STATE INDIVIDUALS IN A REAL TIME SETTING.

HOW WILL THESE LOST CAPABILITIES IMPACT YOUR STATE AND THE STATES AROUND YOU?

CALIFORNIA LAW ENFORCEMENT WILL CONTINUE TO OPERATE IN A PAPER, FACSIMILE RELIANT PROCESS THAT JEOPARDIZES OFFICER SAFETY AND EFFICIENCY. IT IS BELIEVED THAT THE IMPLEMENTATION OF RECEIVING OUT OF STATE DRIVER'S LICENSE PHOTOGRAPHS ELECTRONICALLY WILL CREATE MOMENTUM FOR THE DMV TO ELECTRONICALLY SHARE CALIFORNIA DRIVER'S LICENSE PHOTOGRAPHS OUT OF STATE.

HOW ARE YOU ACCOMPLISHING THIS CURRENTLY?

THE DOJ IS NOT PARTICIPATING CURRENTLY.

IF YOUR BRODY ASSISTANCE FUND APPLICATION IS UNSUCCESSFUL, WHAT WILL THE TIMELINE BE FOR YOU TO ACCOMPLISH WITH STATE FUNDS?

UNDETERMINED AND UNLIKELY. THIS WOULD BE A GENERAL FUND REQUEST AND THE DOJ WOULD HAVE TO GIVE UP AN EQUAL GENERAL FUND AMOUNT, FROM THE CURRENT BUDGET, TO OFF-SET SUCH A REQUEST AND THE DOJ HAS NOT DONE THIS FOR MANY FISCAL YEARS.

Statement of Work

California Department of Justice

CLETS

Statement of Work

NLETS XML DL Photo Retrieval Effort

~~ Provided By ~~

CLETS Support Services Section

December 2014

Statement of Work

The following Data flow diagram depicts the CLETS architectural position role in the processing of the DL Photo Retrieval message keys from the perspective of California requests for out-of-state DMV driver license photos.

CA DQ DMV Queries to Other States

December 2014

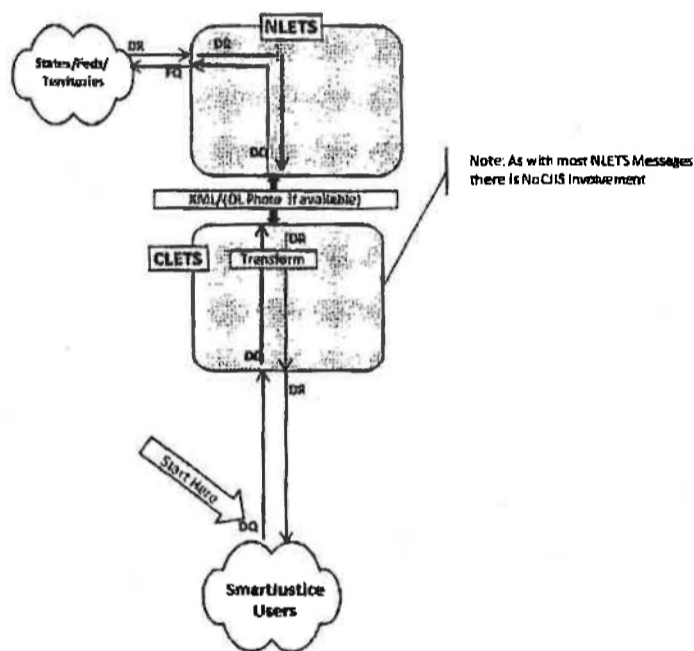

Assumptions/Description of Scope	Who is responsible
1. Within California, NLETS photos can only be retrieved via California's SmartJustice Application Portal.	NLETS/CLETS
2. SmartJustice DQ queries to out of state DMVs are received in JSON format. CLETS transforms these queries to Legacy format prior to sending them to NLETS.	NLETS/CLETS
3. All DR responses from NLETS are returned in NLETS NIEM format. CLETS uses NLETS provided style sheets (XSLT) to transform text content to its equivalent Legacy format prior its delivery. Photo content is extracted and forwarded to its SmartJustice user within a JSON structure.	NLETS/CLETS
4. California Department of Justice will only be a consumer of the NLETS DL Photos at this time. This effort does not include the sending of CA DMV Photos to NLETS.	NLETS/CLETS

Statement of Work

2.1 CA DOJ NLETS Photo Sharing Deliverables

CA DOJ shall be responsible to deliver the following:

- Define the following XML test instances:
 - JSON formatted DQ queries for transformation to NIEM XML or Legacy format for delivery to NLETS.
 - Transform NIEM XML formatted DR responses for transformation to JSON format for delivery to SmartJustice or Legacy format for SmartJustice or MSC users.
- Obtain and validate the XSLT stylesheets from NLETS for the transformations related to the DL Photo Retrieval Project:
- Define the CLETS components of the DL Photo Retrieval Project's Acceptance Testing in conjunction with the DOJ and NLETS members of the project team.
- Support user acceptance testing.

Statement of Work

3 Responsibilities

Each of the participating parties (NLETS and California DOJ) involved in this project will have certain responsibilities as described below:

NLETS Responsibilities:

- Provide (and maintain) DQ & DR interface and format requirements
- Identify non-California test cases and coordinate access to test systems
- Provide coordination of activity related to problem reporting and resolution
- Coordinate with CA DOJ the production implement and support

CLETS Specific Responsibilities:

- Identify the DQ and DR message format requirements
- Validate the requirements, correct and approve
- Document the testing message instances
- Provide CA DOJ with project task list
- Receive project plan, review and adhere to plan
- Support CLETS unit and integration level testing
- Coordinate system testing with NLETS and CA DOJ
- Track CLETS specific testing, requested corrections and retesting, as needed
- Provide ongoing support post-implementation

California DOJ Responsibilities:

- Provide support for the system environment to insure proper testing, operation and readiness
- Provide network connections to internal and external systems
- Provide remote access to the required CLETS DOJ User Systems, e.g., SmartJustice
- Coordinate system testing in cooperation with NLETS and other CA DOJ team participants
- Approve requirements
- Document requirements
- Coordinate software development and testing
- Coordinate and approve Acceptance
- Coordinate and approve Implementation

Statement of Work

4 Pricing

The following table presents the pricing associated with the tasks for this statement of work. In order for Vendor to deliver the working software in the required time frames, all parties must work closely together to insure that all required facilities are provided in a timely manner.

Description	Cost	Quantity	Total
Validate XSLT style sheets from NLETS for following transformations: <ul style="list-style-type: none"> • DQ JSON and Legacy to XML • DR XML to JSON and Legacy 	\$10,000.00	1	\$10,000.00
Define Test Instances <ul style="list-style-type: none"> • In State Requests to Other States (DQ and DR) 	\$10,000.00	1	\$10,000.00
Define CLETS and SmartJustice components of NLETS DL Photo Retrieval Project Acceptance Test Plan	\$10,000.00	1	\$10,000.00
Project Management, testing, support, and documentation	\$10,000.00	1	\$10,000.00
One (1) year warranty, maintenance and support	Included	1	Included
Total Cost			\$40,000.00

NOTE 1: Warranty shall commence after 10 days of production operation and included in existing CLETS maintenance contract.

NOTE 2: Any CLETS software changes (switch, configuration, and archive services) required to implement the NLETS Photo Sharing (DQ and DR) are not included under this Statement of Work and are subject to the existing maintenance support contract.